

FILED
JAN 16 2018

BEFORE THE CORPORATION COMMISSION OF OKLAHOMA

COURT CLERK'S OFFICE - OKC
CORPORATION COMMISSION
OF OKLAHOMA

IN THE MATTER OF THE APPLICATION OF)
OKLAHOMA GAS AND ELECTRIC COMPANY)
FOR AN ORDER OF THE COMMISSION)
AUTHORIZING APPLICANT TO MODIFY ITS)
RATES, CHARGES, AND TARIFFS FOR RETAIL)
ELECTRIC SERVICE IN OKLAHOMA)

CAUSE NO. PUD 201700496

Direct Testimony

of

Lanny Nickell

Vice President of Engineering for the Southwest Power Pool, Inc.

on behalf of

Oklahoma Gas and Electric Company

January 16, 2018

Lanny Nickell
Direct Testimony

1 Q. **Please state your name, your employer, position and business address.**

2 A. My name is Lanny Nickell. I am the Vice President of Engineering for Southwest Power
3 Pool, Inc. (“SPP”) and am testifying on behalf of Oklahoma Gas and Electric Company
4 (“OG&E” or “Company”). My business address is 201 Worthen Drive, Little Rock,
5 Arkansas 72223.

6
7 Q. **Briefly summarize your education and professional background in the electric utility
8 industry.**

9 A. I earned a Bachelor’s Degree in Electrical Engineering from the University of Tulsa. Prior
10 to being named Vice President, Engineering, I served as SPP’s Vice President, Operations
11 and, before that, in various management and engineering roles within the Operations
12 Department. Prior to joining SPP in 1997, I served in various engineering roles with
13 Public Service Company of Oklahoma and Central and South West Services. I have
14 served on numerous SPP and North American Electric Reliability Corporation (“NERC”)
15 committees working to develop and effectuate regional and national transmission
16 operations, planning, and market development policies.

17
18 Q. **What are your responsibilities as Vice President of Engineering for SPP?**

19 A. I am directly responsible for providing strategic and tactical leadership to SPP’s
20 Engineering department necessary to ensure successful completion of goals and essential
21 functions assigned to that group, including the development of transmission expansion
22 plans that ensure reliable and efficient usage of a regional transmission grid covering all or
23 parts of fourteen states. I also oversee the coordination, tracking, and monitoring of
24 approved transmission expansion projects, the performance of technical studies necessary
25 to process requests for interconnection of generation resources and requests for long-term
26 transmission service, and the provision of engineering support as necessary for members,
27 customers, and regulators.

1 Q. **Please describe SPP.**

2 A. SPP is a Federal Energy Regulatory Commission (“FERC”) approved Regional
3 Transmission Organization (“RTO”). It is an Arkansas non-profit corporation with its
4 principal place of business in Little Rock, Arkansas. SPP currently has 95 members in
5 fourteen states with a service territory of more than 575,000 square-miles. SPP’s
6 members include 16 investor-owned utilities, 14 municipal systems, 20 generation and
7 transmission cooperatives, 8 state agencies, 14 independent power producers, 12 power
8 marketers, 10 independent transmission companies, and 1 federal agency.

9 SPP, in its role as an RTO, currently administers transmission service over 60,944
10 miles of transmission lines covering portions of Arkansas, Iowa, Kansas, Louisiana,
11 Minnesota, Missouri, Montana, Nebraska, New Mexico, North Dakota, Oklahoma, South
12 Dakota, Texas, and Wyoming. These services include reliability coordination, tariff
13 administration, regional scheduling, transmission expansion planning, market operations,
14 compliance, and training.

15

16 Q. **What is SPP’s relationship to OG&E?**

17 A. OG&E is a transmission owning member of SPP.

18

19 Q. **Have you previously testified before this Commission?**

20 A. Yes, I submitted written testimony in Cause No. PUD 201300217.

21

22 Q. **Why are you submitting testimony in this docket?**

23 A. OG&E had previously submitted testimony in both Oklahoma and Arkansas regarding the
24 reliability benefits of replacing the retiring steam units at the Mustang generating station
25 with quick start combustion turbines (“CTs”). OG&E asked that I prepare testimony to
26 provide independent validation of those benefits by (i) discussing SPP’s use of quick start
27 CTs in its reliable operation of the transmission system and (ii) citing to recent studies that
28 show how critical it is to have continued generation (especially quick start CTs) at the
29 Mustang site.

1 Q. **What is the purpose of your testimony?**

2 A. My testimony will discuss and explain studies conducted by SPP that show that generation
3 at the Mustang site and especially quick-start CTs at that site provide unique reliability
4 benefits to the transmission system. I will also testify why those benefits are important to
5 SPP and to customers in Oklahoma.

6
7 Q. **What is your understanding of OG&E's plan for the Mustang generating station?**

8 A. My understanding is that OG&E is in the process of replacing the capacity of the existing
9 steam units at the Mustang generation site with natural gas-fired, quick-starting CTs.

10
11 Q. **Does SPP use quick-start CTs to ensure reliable operation of the transmission
12 system?**

13 A. Yes. SPP typically relies on quick-start resources to maintain grid reliability during
14 unforeseen operating circumstances, including rapid loss of generation or higher than
15 expected increases in load. SPP requires that quick-start resources necessary to provide
16 sufficient contingency reserves be capable of being applied in time to meet NERC's
17 Disturbance Control Standard requirements.¹ Quick-start resources are useful in
18 facilitating reliable integration of increased levels of renewable generation and its
19 associated volatility, due to their ability to quickly inject real and reactive power into the
20 system.

21
22 Q. **Do quick-start CTs and renewable generation, such as wind and solar, complement
23 one another?**

24 A. Yes. CTs complement variable renewable resources because they typically can be started,
25 synchronized and capable of injecting a substantive amount of energy (including voltage
26 support), within ten (10) minutes of notification. As the output of variable resources
27 rapidly decreases or increases, quick-start CTs can quickly be started, stopped, and re-
28 dispatched to balance these sudden changes in energy. Furthermore, as imports into areas

¹ NERC's Disturbance Control Standard (BAL-002) requires that a Balancing Authority return its post-contingency control performance to pre-contingency measurements within 15 minutes.

1 of relative high-load intensity suddenly increase, nearby quick-start CTs can provide
2 reactive support to those areas as needed to maintain proper system voltages.
3

4 **Q. Has SPP conducted any studies that show the potential benefits of generation at the**
5 **Mustang site?**

6 A. Yes. SPP recently conducted the 2017 Variable Generation Integration Study (“VIS”),
7 attached as Direct Exhibit LN-1, which evaluated wind penetration levels at 45% and
8 60%. The study showed that even at wind generation levels below those that SPP has
9 recently experienced,² voltage collapse and system overloads could occur, under certain
10 credible circumstances, without generation at the Mustang site. As I mentioned above,
11 quick-start CTs, such as the ones planned for the Mustang site, can be utilized quickly to
12 balance sudden changes in energy and would be necessary to alleviate certain of the
13 voltage collapse scenarios studied in the VIS.
14

15 **Q. Could you please explain how this study was conducted and the results which led to**
16 **your conclusion above?**

17 A. The 2017 VIS analyzed various aspects of SPP transmission system performance for the
18 years 2017 and 2021 under 45% and 60% wind penetration levels. The VIS included
19 assessments of transient stability, voltage stability, system frequency behavior, and
20 ramping capability.

21 Results from the voltage stability analysis demonstrated that generation at the
22 Mustang site would effectively resolve a number of system overloads and provide voltage
23 support during times of high energy transfers from wind generation across SPP. The
24 purpose of this analysis was to determine the point at which wind penetration or transfer
25 levels caused voltage instability under various operating scenarios, some of which
26 included transmission outages that would typically exist during the time of year studied.
27 The analysis indicated that voltage collapse could occur in a number of different areas of
28 SPP, primarily southern Oklahoma, which includes Oklahoma City, southwestern New

² SPP experienced a wind penetration record when over 54% of its load was served by wind generation on March 19, 2017.

1 Mexico and northwestern North Dakota. Depending on the year modeled and outage
2 conditions studied, voltage instability was observed at wind penetration levels ranging
3 from 45% to 63.3%. During the analysis, if studied transfers caused transmission system
4 overloads, generation would be redispatched to mitigate those overloads. The analysis
5 showed that generation at the Mustang site is needed to effectively mitigate a real-time
6 overload on the Cimarron-Draper 345 kV line. It also demonstrated that the CTs at the
7 Mustang site are needed to mitigate voltage instability in various parts of Oklahoma,
8 including Oklahoma City, after loss of the Tatonga-Matthewson 345 kV line during
9 periods of high wind generation transfers and low load. The analysis reflected that in
10 these conditions a large amount of thermal generation would have been cycled off-line and
11 not available to effectively deal with energy reliability issues resulting from wind transfers
12 and unexpected system outages. Turning on quick-start CTs in the Oklahoma City area
13 would allow for additional voltage support plus provide congestion relief on the 345kV
14 network in western Oklahoma where a significant amount of wind generation is located.

15 After Mustang generation was turned on and dispatched in the voltage stability
16 analysis, it provided voltage support and congestion relief for the western Oklahoma and
17 Oklahoma City areas. The VIS analytical results demonstrate the value that generation at
18 the Mustang site can provide by resolving system overloads and providing voltage support
19 during any number of plausible operating conditions. That value increases with quick-
20 start CTs due to quicker start-up and ramp rates, especially during conditions where
21 thermal units would not be on-line.

22
23 **Q. Why is it important for OG&E to have reactive support at the Mustang site when**
24 **maintaining the reliability of the system?**

25 **A.** A system's ability to operate within acceptable voltage limits is the best indicator of the
26 sufficiency of the reactive support capability of that system. As the system load continues
27 to grow and more power is imported, due to both the SPP Integrated Marketplace and
28 production from an ever increasing number of remote wind facilities, even more local
29 reactive support is going to be required. With SPP's recent wind penetration levels
30 exceeding 54%, generation at the Mustang site has already provided an effective

1 mitigation of reliability threats in the Oklahoma City area.³ Given expected future
2 increases in wind penetration, the Mustang CTs are expected to provide SPP improved
3 capability, through provision of voltage and power support, to offset increasing reliability
4 risks in the Oklahoma City area. As discussed by OG&E Witness Greg McAuley, the new
5 Mustang CTs will be capable of supplying greater amounts of reactive power than the old
6 Mustang steam units.

7
8 **Q. Did SPP conduct any additional studies?**

9 A. Yes. SPP also performed single contingency (“N-1”) analyses for the summer and winter
10 peak conditions expected during 2018 and 2021. Similar to the VIS, this analysis also
11 demonstrated that generation at the Mustang site is useful in preventing and reducing
12 thermal overloads on area transmission facilities. If generation facilities at Mustang are
13 retired and not replaced, transmission overloads during first contingency conditions (N-1)
14 would likely be observed in SPP’s transmission planning studies and may require that SPP
15 direct construction of transmission upgrades in accordance with its Open Access
16 Transmission Tariff (“OATT”).

17
18 **Q. How do customers in Oklahoma benefit from the Mustang CTs?**

19 A. Oklahoma customers benefit from the Mustang CTs because they improve SPP’s ability to
20 maintain real-time system reliability while enabling increased production from a growing
21 supply of renewable resources, particularly those located west of the Oklahoma City area.
22 The ability to reliably increase renewable resource production because quick-start
23 resources are available, such as those proposed at the Mustang site, will reduce energy
24 costs to all customers participating in the SPP market, including those in Oklahoma.
25 Without the Mustang CTs, SPP would likely have to rely on less effective alternatives to
26 resolve voltage and thermal issues in and around the Oklahoma City area. System voltage
27 degradation in the Oklahoma City area, if not addressed quickly with effective local
28 resources, could rapidly propagate and expose other areas throughout the SPP region, to

³ Over a 12-month period ending May of 2017, SPP manually committed Mustang generation a total of 35 times for a period of 334 hours in order to resolve relevant local reliability issues.

1 potential loss of load. Further, additional transmission upgrades could be necessary to
2 help mitigate these reliability and congestion issues. If construction of transmission
3 upgrades are required, all or a portion of the Annual Transmission Revenue Requirements
4 for those upgrades would be added to SPP's zonal transmission rates, including OG&E's,
5 in accordance with the SPP OATT, causing Oklahoma ratepayers to bear some of those
6 costs.

7
8 **Q. Do you have any additional thoughts?**

9 A. Yes. The availability of generation at the Mustang site is critical to reliable system
10 operations in the Oklahoma City area. The generation OG&E has chosen, fast-start CTs,
11 provides a valuable reliability tool to more quickly respond to system loading and voltages
12 in the largest load center of Oklahoma.

13 I believe the need for and the reliability benefit of quick-start CTs will grow as the
14 amount of wind capacity in SPP grows. Nearly 17,000 MW of installed wind nameplate
15 capacity, representing nearly 20% of SPP's capacity mix, is currently operating in the SPP
16 Balancing Authority Area footprint and participating in the SPP Integrated Marketplace.
17 An additional 4,500 MWs of wind generation capacity is currently on schedule to be
18 installed on the SPP system by the end of 2018, with over 30,000 MWs of additional wind
19 nameplate capacity currently being studied in SPP's generator interconnection study
20 queue. Properly located quick-start CTs will improve SPP's ability to reliably manage the
21 amount of wind growth that SPP could continue to see in its footprint.

22
23 **Q. Does this conclude your testimony?**

24 A. Yes, it does.



2017 VARIABLE GENERATION INTEGRATION STUDY

January 5, 2017

Operations and Planning Engineering

Powertech



SPP *Southwest
Power Pool*



REVISION HISTORY

Date or Version Number	Author	Change Description	Comments
9/15/2016	Jason Tanner	Draft Report	Added Executive Summary And Introduction
9/29/2016	Brandon Hentschel	Draft Report	Added Model Development
10/14/2016	Theva Chanthaseny	Draft Report	Added Transient Stability Analysis
10/18/2016	Frederic Howell (PLI) George Zheng (PLI) Alexander De Maeseneer (PLI)	Draft Report	Added Sections 7 and 8
10/21/2016	Ricky Finkbeiner	Draft Report	Added Section 9
10/25/2016	Frederic Howell (PLI) George Zheng (PLI) Alexander De Maeseneer (PLI)	Draft Report	Updated Sections 7 and 8
11/11/2016	Doug Bowman	Draft Report	Added Sections 5 and 6
11/11/2016	Scott Jordan	Draft Report	Updated Section 4 language
11/11/2016	Jason Tanner	Draft Report	Updated Section 4 charts
11/11/2016	Ricky Finkbeiner	Draft Report	Updated Section 9 analysis

TABLE OF CONTENTS

REVISION HISTORY	2
TABLE OF CONTENTS	3
EXECUTIVE SUMMARY	7
1.1 OVERVIEW	7
1.2 STUDY APPROACH.....	7
1.3 MAJOR FINDINGS	8
1.4 RECOMMENDATIONS.....	8
GLOSSARY.....	9
2.1 GLOSSARY TERMS.....	9
INTRODUCTION.....	18
3.1 BACKGROUND AND OBJECTIVES OF THE STUDY.....	18
3.2 THE SOUTHWEST POWER POOL.....	18
3.3 KEY CHALLENGES FOR THE INTEGRATION OF VARIABLE GENERATION	18
SPP MODEL DEVELOPMENT.....	20
4.1 STEADY STATE MODELING.....	20
4.2 VIS OUTAGE SUMMARY.....	23
4.3 DYNAMICS MODELING.....	24
TRANSIENT STABILITY ANALYSIS FOR 45% AND 60% WIND PENETRATION	25
5.1 OVERVIEW AND OBJECTIVE	25
5.2 DEFINITIONS.....	25
5.2.1 Transient Stability	25
5.2.2 Oscillation Damping	25
5.2.3 Transient Voltage Response.....	26
5.3 STABILITY ANALYSIS MODELS AND DATA.....	28
5.3 ANALYSIS.....	28
5.3.1 Step 1: FFS Screening.....	28
5.3.2 Step 2: Stability Analysis	29
5.4 RESULTS	31
5.5 CONCLUSION.....	38

FREQUENCY RESPONSE ANALYSIS FOR 45% AND 60% WIND PENETRATION.....39

- 6.1 FREQUENCY RESPONSE ANALYSIS OVERVIEW39
- 6.2 FREQUENCY RESPONSE DEFINITIONS.....39
 - 6.2.1 Frequency Response:.....39
 - 6.2.2 Arresting Period:40
 - 6.2.3 Rebound Period:.....40
 - 6.2.4 Recovery Period:40
- 6.3 FREQUENCY RESPONSE ANALYSIS.....41
 - 6.3.1 Models and Data:41
 - 6.3.2 Analysis:.....42
 - 6.3.3 Results:42
- 6.4 CONCLUSION.....46

SEASONAL VOLTAGE STABILITY ANALYSIS 2017 AND 202147

- 7.1 OVERVIEW OF VOLTAGE STABILITY.....47
- 7.2 POWER TRANSFER AND REACTIVE RESERVES.....49
- 7.3 OVERVIEW OF VOLTAGE STABILITY ANALYSIS.....52
- 7.4 SIMULATION CASE SETUP.....52
- 7.5 BASE CASE CLEANUP.....53
- 7.6 2017 45% WITH OUTAGES CASE.....54
 - 7.6.1 CONSTRAINT RE-DISPATCH ACTIONS56
 - 7.6.2 DISPATCH BALANCING FOR MAINTAINING WIND PENETRATION.....57
 - 7.6.3 DISPATCH FOR VOLTAGE STABILITY ISSUES AFTER BALANCING.....58
 - 7.6.4 Woodward Phase Shifter Effect60
 - 7.6.5 Voltage Violations61
- 7.7 2017 45% WITHOUT OUTAGES CASE.....61
 - 7.7.1 CONSTRAINT RE-DISPATCH ACTIONS62
 - 7.7.2 V-P Curve and Q-V Curves64
 - 7.7.3 Woodward Phase Shifter Effect67
 - 7.7.4 Voltage Violations67
- 7.8 2021 45% WITH OUTAGES CASE.....69
 - 7.8.1 CONSTRAINT RE-DISPATCH ACTIONS71
 - 7.8.2 V-P Curve and Q-V Curves73
 - 7.8.3 Voltage Violations75
- 7.9 2021 45% WITHOUT OUTAGES CASE.....76

7.9.1 Overload Issues in Base Case.....	78
7.9.2 Overload Issues During Transfer	78
7.9.3 Voltage Violations	79
7.10 2021 60% WITHOUT OUTAGES CASE.....	81
7.10.1 Overload Issues in Base Case.....	83
7.10.2 Overload Issues During Transfer	84
7.10.3 Voltage Violations.....	85
SEASONAL LOAD POCKET ANALYSIS 2017 AND 2021.....	87
8.1 OVERVIEW OF SEASONAL LOAD POCKET ANALYSIS	87
8.2 SIMULATION CASE SETUP	87
8.3 BASE CASE CLEANUP.....	88
8.4 BASE CASE OVERLOADS	89
8.5 BASECASE RE-DISPATCH.....	90
8.5.1 BASECASE CONSTRAINT RE-DISPATCH ACTIONS	90
8.5.2 DISPATCH BALANCING FOR MAINTAINING WIND PENETRATION.....	92
8.5.3 DISPATCH FOR VOLTAGE STABILITY ISSUES AFTER BALANCING.....	92
8.6 VOLTAGE VIOLATIONS	94
8.7 TRANSFER SETUP	96
8.8 AREA1: EASTERN NEBRASKA(LINCOLN, OMAHA).....	97
8.9 AREA2: SOUTH OKLAHOMA	103
8.9.1 Inclusion of Woodward Phase Shifter.....	107
8.10 AREA3: SPS-SOUTH	108
8.10.1 Amoco Load Correction.....	116
8.11 AREA4: WEST OKLAHOMA	118
8.11.1 Inclusion of Woodward Phase Shifter.....	119
8.12 AREA5: SOUTH CENTRAL WESTAR	121
8.13 AREA6: KANSAS CITY	122
8.14 AREA7: OKLAHOMA CITY	123
8.15 AREA8: WILLISTON.....	124
8.16 SUMMARY	130
TARGETED 5 MINUTE ANALYSIS FUTURE RAMPING 5 YEAR OUTLOOK	131
9.1 OVERVIEW	131
9.2 MODELS USED.....	131

9.3 SCENARIO DEVELOPMENT131

9.4 LOAD CURVES.....132

9.5 RESOURCE FORECAST CURVES133

9.6 Other Scenario Modeling Information.....136

 9.6.1 Commitments, Start-ups, and Shut-downs136

 9.6.2 Transmission Constraints136

 9.6.3 Ancillary Services and other Obligations.....136

9.7 Scenario and Sub-Scenario Results137

 9.7.1 Spring – Load Ramp Down, Wind Ramp Up137

 9.7.2 Winter – Morning Load Increase, Wind Ramp Down141

 9.7.2 Summer – Load Ramp Up, Wind Ramp Down.....143

9.8 Summary145

APPENDICES146

 1.Open Electrical: AC Power Transmission³146

 Introduction.....146

 Power-Angle Relationship146

 Steady-State Voltage Stability Limits.....148

 BEPC Comments150

REFERENCES.....158

EXECUTIVE SUMMARY

1.1 OVERVIEW

The Southwest Power Pool (SPP) in 2009 conducted a Wind Integration Study, which forecasted a significant increase of installed wind capacity in the region. As a result, SPP implemented a number of recommendations from the study to ensure continued reliable operation of the power grid. With the 2014 launch of the SPP Integrated Marketplace, the 2015 addition of the Integrated System as an SPP member and additional wind capacity currently in queue, SPP conducted a new Wind Integration Study in 2015 to determine the operational and reliability impacts of integrating increased wind generation into the SPP transmission system. The study required detailed engineering analysis and significant effort to interpret the study results and findings. The study assessed the reliability impacts associated with additional wind generation resources installed within the SPP operating area. In 2016 SPP partnered with Powertech Labs to begin work on a second phase of the Wind Integration Study called the Variable Generation Integration Study (VIS). The analysis performed in the VIS included transient stability for 2017, frequency response for 2017, voltage stability for 2017 and 2021, load pocket analysis, and a targeted 5 minute ramping analysis.

1.2 STUDY APPROACH

The 2017 Variable Generation Integration study analyzed the SPP transmission system for the years 2017 and 2021. SPP in conjunction with Power Tech Labs (PLI) assessed transient stability for the spring 2017 outlook utilizing 45%, and 60% wind penetration. Two sets of models, a base planning case and a planning model with historical operations outages included were analyzed. SPP utilized V&R Energy's Fast Fault Scan (FFS) tool to determine the more severe N-2 fault locations in the SPP region for each case, where these locations were ranked according to critical clearing times. The transient stability analysis for disturbance events was completed using DSATools TSAT for the FFS events with critical clearing times less than 9 cycles. During the stability simulations, monitored parameters included rotor angle and speed, real and reactive power, bus voltages greater than 100kV in the disturbance area, transient voltage response, and machine rotor angle damping. The parameter values were compared with the *SPP Disturbance Performance Requirements* criteria.

SPP also perform a time domain simulation study of the system frequency behavior following a sudden loss of selected large generating unit(s), with different amounts of wind generation and operating reserves. The studies performed used the 45% and 60% wind penetration Spring MDWG 2017 base cases (ops outages included) and existing MDWG dynamics data for wind turbines. Frequency responses examined were compared to existing under frequency load-shedding set points to determine the inertial response, the frequency nadir, and the settled frequency following the loss of generation.

SPP also perform a targeted 5 minute analysis future ramping 5 year outlook. The scenarios ran with 5-minute granularity, designed to assess performance of the SPP system over varying ranges of ramping. These scenarios and ramping ranges use existing market software (Market Clearing Engine for RTBM solution) to represent, based on current design and protocols, how SPP would operate across these ramping ranges. The analysis assessed four-hour horizons and scenarios that simulated typical situations where higher ramping needs would be expected. Because solar is not projected to have as large of an impact in the next five years as wind, the ramping analysis scenarios will focus

on times when load and wind are moving in opposite directions (Net Load increasing or decreasing quickly). Wind and Solar ramping values considered was based on historical analysis, coupled with various capacity projections for five years out (using GI queue). The analyses performed utilized scenarios such as the spring evening load drop with wind increasing and simulate varying levels of wind/solar changes at the time (e.g. ramps of 4 GW, 8 GW, 12 GW... over the simulation period)

Powertech Labs performing a voltage stability study to determine stability for the 45% and 60% wind penetration Spring MDWG 2017 and 2021 base cases (with and without ops outages). Two sets of models, a base planning case and a planning model with historical operations outages included were analyzed. Single contingencies on the base models included SPP lines and transformers above 100kV, interfaces, flowgates and circuits. Monitored elements included NERC event monitored elements and SPP thermal overloads due to transfers. Voltage instability prior to reaching thermal limits was cause for re-dispatch to avoid voltage collapse, and if local voltage stability or thermal limits were reached, a generation re-dispatch was performed utilizing a block dispatch in the following order: 1st thermal units (except Nuclear)(Gas to pmin then offline and Coal to pmin then offline), 2nd DVERS (dispatchable variable energy resources)(Hydro/Wind/Solar), 3rd NDVERS (Non-dispatchable Variable Energy Resources)(Hydro/Wind), to remedy the violation. The analysis performed was looking for a 5% voltage stability margin to be reported for wind transfers, flowgate limits, and load increase limits. The base models included SPP firm wind commitment for external areas, and a load pocket analysis was also performed by increasing load within the load pocket while increasing wind transfer to the load area. The transfer increased while under contingency until voltage collapse occurred on the transmission system, and a 5% stability margin was used for the transfer limit to allow for Reactive reserves to be determined at the point of voltage collapse.

The load pockets analyzed were:

- Area 1: Eastern Nebraska (Lincoln, Omaha),
- Area 2: South Oklahoma,
- Area 3: SPS – South,
- Area 4: West Oklahoma (Woodward Area),
- Area 5: South Central Westar (Wichita Load Area),
- Area 6: Kansas City,
- Area 7: Oklahoma City, and
- Area 8: Williston.

1.3 MAJOR FINDINGS

This section of the report will be updated after completion of the report analysis.

1.4 RECOMMENDATIONS

This section of the report will be updated after completion of the report analysis.

GLOSSARY

2.1 GLOSSARY TERMS

Asset Owner

An owner of any combination of: (1) registered physical assets (Resource, load, Import Interchange Transaction, Export Interchange Transaction, Through Interchange Transaction), (2) Transmission Congestion Rights or (3) any combination of financial assets (Virtual Energy Offer, Virtual Energy Bid, Bilateral Settlement Schedules) within the SPP Balancing Authority Area.

Balancing Authority

As defined in the SPP Tariff.

Balancing Authority Area

As defined in the SPP Tariff. As defined in Attachment AE of the SPP Tariff.

Bulk Electric System (BES)

All Transmission Elements operated at 100 kV or higher. This does not include facilities used in the local distribution of electric energy. Inclusions and exclusions apply.¹

Central Prevailing Time (CPT)

Clock time for the season of a year, i.e. Central Standard Time and Central Daylight Time.

Common Bus

A single bus to which two or more Resources that are owned by the same Asset Owner are connected in an electrically equivalent manner where such Resources may be treated as interchangeable for certain compliance monitoring purposes.

Congestion Management Event (CME)

An event during which constraints are activated in RTBM in order to re-dispatch the system to reduce the impact of SPP Market Flow on a Coordinated Flowgate or Reciprocal Coordinated Flowgate or in order to redispatch the system to remove projected limit violation on flowgates other than a Coordinated Flowgate or Reciprocal Coordinated Flowgate. This event may entail a parallel issuance of TLR.

Contingency Reserve

As defined in the SPP Tariff.

Day-Ahead

The time period starting at 0001 and ending at 2400 on the day prior to the Operating Day.

Day-Ahead Market (DA Market)

¹ [NERC, Bulk Electric System Definition Reference Document](#), version 2, April 2014, page 3.

The financially binding market for Energy and Operating Reserve that is conducted on the day prior to the Operating Day.

Day-Ahead Reliability Unit Commitment (Day-Ahead RUC)

The process performed by SPP following the close of the DA Market and prior to the Operating day to assess resource and operating reserve adequacy for the Operating Day, commit and/or de-commit Resources as necessary, and communicate commitment or de-commitment of Resources to the appropriate Market Participants as necessary.

De-Commit Time

The time specified by SPP or a local Transmission Operator in a de-commit order at which a Resource should begin de-synchronization procedures.

Designated Resource

As defined in the SPP Tariff.

Desired Dispatch

A MW value calculated from a Resource’s RTBM Energy Offer Curve that represents the point at which the Resource’s incremental Energy offer first exceeds the Resource’s RTBM LMP.

Dispatch Instruction (DI)

The communicated Resource target energy MW output level at the end of the Dispatch Interval.

Dispatch Status

A parameter submitted as part of a Resource Offer that specifies the option under which the Resource is to be dispatched once the Resource has been committed and becomes a Synchronized Resource.

Dispatchable Demand Response Resource

A controllable load, including behind-the-meter generation, that is a Dispatchable Resource that can reduce the withdrawal of Energy from the transmission grid when directed by SPP.

Dispatchable Resource

A Resource for which an Energy Offer Curve has been submitted and that is available for dispatch by SPP on a Dispatch Interval basis.

Dispatchable Variable Energy Resource (DVER) A Variable Energy Resource that is capable of being incrementally dispatched down by the Transmission Provider.

Dynamic reactive reserves (DRR)

Reactive reserves that can be used to rapidly respond to system voltage deviations. SVCs, SC, and synchronous generators provide dynamic reactive reserves.

Dynamic Security Assessment Software (DSATools)

A suite of state-of-the-art power system analysis tools and provides the capabilities for a comprehensive system security assessment, including all forms of stability.

Electric Industry Registry (EIR)

The Electric Industry Registry serves as a central repository of information that is required for commercial interactions.

Emergency

As defined as Emergency Condition in the SPP Tariff.

Energy

An amount of electricity that is Bid or Offered, produced, purchased, consumed, sold or transmitted over a period of time, which is measured or calculated in megawatt hours (MWh).

Energy and Operating Reserve Markets

The Day-Ahead Market and Real-Time Balancing Market.

Energy Management System (EMS)

The software system used by SPP for the real-time acquisition of operating data and operations.

Export Interchange Transaction

A Market Participant schedule for exporting Energy out of the SPP Balancing Authority Area.

Import Interchange Transaction

A Market Participant schedule for importing Energy into the SPP Balancing Authority Area.

Interchange Transaction

Any Energy transaction that is crossing the boundary of the SPP Balancing Authority Area and requires checkout with one or more external Balancing Authority Areas. This includes any Import Interchange Transaction, Export Interchange Transaction and/or Through Interchange Transaction.

Intra-Day Reliability Unit Commitment (IDRUC)

The process performed by SPP following the completion of the DA RUC and throughout the Operating day to assess Resource and Operating Reserve adequacy for the Operating Day, commit and/or de-commit Resources as necessary, and communicate commitment or de-commitment of Resources to the appropriate Market Participants as necessary.

Jointly Owned Resource (JOU)

A Resource that is owned by more than one Asset Owner.

Load Serving Entity (LSE)

As defined in Attachment AE of the Tariff.

Local Emergency Condition (LEC)

As defined in the SPP Tariff

Local Reliability Issue (LRI)

As defined in the SPP Tariff.

Locational Marginal Price (LMP)

The market clearing price for Energy at a given Price Node which is equivalent to the marginal cost of serving demand at the Price Node while meeting SPP Operating Reserve requirements.

Long-Term Congestion Right (LTCR)

As defined in Attachment AE of the Tariff.

Manual Dispatch Instruction

A dispatch instruction created outside of the normal RTBM SCED Dispatch Instruction solution to address a system reliability condition that could not be resolved by the RTBM SCED.

Market Clearing Price (MCP)

The price used for settlements of an Operating Reserve product in each Reserve Zone. A separate price is calculated for Regulation-Up Service, Expected Regulation-Up Mileage, Regulation-Down Service, Expected Regulation-Down Mileage, Spinning Reserve and Supplemental Reserve.

Market Flow

The impact on transmission system flowgate flows resulting from an operational entity's Resources serving market load within a defined market footprint.

Market Participant (MP)

As defined in the SPP Tariff.

Megawatt (MW)

A measurement unit of the instantaneous demand for energy.

Mid-Term Load Forecast

A Settlement Area Load forecast developed by SPP on a rolling hourly basis for the next seven days for input into Reliability Unit Commitment.

Net Actual Interchange

The algebraic sum of all metered interchange over all interconnections between two physically adjacent Balancing Authority Areas.

Net Benefits Test

As defined in the SPP Tariff.

Net Scheduled Interchange

The algebraic sum of all Interchange Transactions between Balancing Authorities for a given period or instant in time.

Non-Dispatchable Variable Energy Resource (NDVER)

A Variable Energy Resource that is not capable of being incrementally dispatched down by the Transmission Provider.

Offer

A commitment to sell (i) a quantity of Energy at a specific minimum price such as a Resource Offer, a Virtual Energy Offer and/or an Import Interchange Transaction Offer, or (ii) a quantity of Transmission Congestion Rights at a specific minimum price, where such quantities may be submitted in 0.1 MW increments.

Operating Day

A daily period beginning at midnight.

Operating Hour

A 60-minute period of time during the Operating Day corresponding to a clock hour typically expressed as hour-ending.

Operating Reserve

Resource capacity held in reserve for Resource contingencies and NERC control performance compliance which includes the following products: Regulation-Up Service, Regulation-Down Service, Spinning Reserve and Supplemental Reserve.

Operating Reserve Only Resource

A Resource that cannot be cleared or dispatched for Energy that is qualified to provide any or all of the Operating Reserve products: Regulation-Up, Regulation-Down, Spinning Reserve, or Supplemental Reserve.

Parallel Flow

Flow on the Transmission System not scheduled with SPP caused by entities external to the SPP Market Footprint. (Also known as loop flow.)

Power Transfer Distribution Factor (PTDF)

The percentage of power transfer flowing through a facility or set of facilities (flowgate) for a particular transfer when there are no contingencies.

Quick-Start Resource

A Resource that can be started, synchronized and inject Energy within ten minutes of SPP notification.

Ramp-Rate-Down

A curve specifying MW/minute ramp rates applicable between Resource operating ranges that is used to dispatch Resources in the down direction.

Ramp-Rate-Up

A curve specifying MW/minute ramp rates applicable between Resource operating ranges that is used to dispatch Resources in the up direction.

Real-Time

The continuous time period during which the RTBM is operated.

Real-Time Balancing Market (RTBM)

The market operated by SPP continuously in real-time to balance the system through deployment of Energy and to clear Regulation-Up, Regulation-Down, Spinning Reserve and Supplemental Reserve.

Reference Bus

The location on the SPP Transmission System relative to which all mathematical quantities, including shift factors and penalty factors relating to physical operation, will be calculated.

Regulation Deployment

The utilization of Regulation-Up Service and/or Regulation-Down Service through Automatic Generation Control (AGC) equipment to automatically and continuously adjust Resource output to balance the SPP Balancing Authority Area in accordance with NERC control performance criteria.

Regulation-Down

As defined in the SPP Tariff.

Regulation Ramp Rate

A curve specifying MW/minute ramp rates that are used to determine a Resource’s maximum Regulation-Up Service and/or Regulation-Down Service quantities.

Regulation Response Time

The maximum amount of time allowed for a Resource to move its output from zero Regulation Deployment to the full amount of Regulation-Up cleared or to move from zero Regulation Deployment to the full amount of Regulation-Down cleared.

Regulation-Up

As defined in the SPP Tariff.

Reported Load

As defined in the SPP Tariff.

Reserved Capacity

The reservation MW between a specified source and sink associated with SPP Transmission Service.

Reserve Sharing Event (RSE)

A request for assistance to deploy Contingency Reserve by any Reserve Sharing Group (RSG) member following the sudden loss of a Resource.

Reserve Sharing Group (RSG)

As defined in the SPP Tariff.

Reserve Shutdown

An SPP approved Resource shutdown that is requested by a Market Participant for the purposes of making the Resource unavailable for SPP commitment and dispatch due to reasons other than to perform maintenance or to repair equipment.

Reserve Zone (RZ)

A zone containing a specific group of Price Nodes for which a minimum and maximum Operating Reserve requirement is established.

Resource

As defined in the SPP Tariff.

Resource Offer For a Resource, the combination of its Start-Up Offer, No-Load Offer, Energy Offer Curve, Regulation-Up Service Offer, Regulation-Down Service Offer, Spinning Reserve Offer and Supplemental Reserve Offer.

Reliability Unit Commitment (RUC)

The process performed by SPP to assess resource and operating reserve adequacy for the Operating Day, commit and/or de-commit resource as necessary, and communicate commitment or de-commitment of Resources to the appropriate Market Participants as necessary.

Security Constrained Economic Dispatch (SCED)

An algorithm capable of clearing, dispatching, and pricing Energy and Operating Reserve on a co-optimized basis that minimizes overall cost while enforcing multiple security constraints.

Security Constrained Unit Commitment (SCUC)

An algorithm capable of committing Resources to supply Energy and/or Operating Reserve on a co-optimized basis that minimizes capacity costs while enforcing multiple security constraints.

Short-Term Load Forecast (STLF)

A Settlement Area Load forecast developed by SPP on a rolling 5-minute basis for the next 120 Dispatch Intervals for input into the Real-Time Balancing Market.

Spinning Reserve

As defined in the SPP Tariff.

SPP Forecast Area

A geographic area within the SPP BA defined by SPP based upon historical operating experience for the purposes of developing load forecasts.

SPP Integrated Marketplace

The Energy and Operating Reserve Markets and the Transmission Congestion Rights Markets.

SPP Region

As defined in the SPP Tariff.

State Estimator

The computer software used to estimate the properties of the electric system based on a sample of system measurements based on current system conditions.

Static VAR compensator (SVC)

VAR sources that are composed of shunt reactors and shunt capacitors. High Speed electronic switching equipment (thyristor switches) are used to adjust the amount of reactors or capacitors in-service at any one time. In an SVC there are no rotating parts every element is static.²

² Electric Power Research Institute, “EPRI Power system Dynamics Tutorial”, EPRI, Palo Alto, CA. 2009. 1016042, available at www.epri.com, Section 5.6.4, pages 5-57 and 5-58.

Synchronous condenser (SC)

A synchronous motor that produces only reactive power.

Synchronized Resource

A Resource that is electrically connected to the grid as evidenced by the closing of the Resource circuit breaker.

System Intact (SI)

Power flow BES model with all normally in-service components on or energized.

Through Interchange Transaction

A Market Participant schedule submitted between two External Interfaces for use in the DA Market or RTBM for moving Energy through the SPP Balancing Authority Area.

Transmission Loading Relief (TLR)

The NERC prescribed method for relieving congestion on Coordinated Flowgates and Reciprocal Coordinated Flowgates through reductions in tagged flow and Market Flow associated with these flowgates.

Variable Energy Resource (VER)

A device for the production of electricity that is characterized by an energy source that: (1) is renewable; (2) cannot be stored by the facility owner or operator; and (3) has variability that is beyond the control of the facility owner or operator.

Voltage Collapse

Voltage Collapse is a Process in which a voltage unstable system experiences an uncontrolled reduction in system voltage.³

Voltage Stability

Voltage stability is the ability of a power system to maintain adequate voltage magnitudes. When the load connected to a voltage stable system is increased, the power delivered to that load also increases. In a voltage stable system both power and voltage are controllable. In a voltage unstable system the system operators have lost control of both voltage magnitude and power transfer.⁴

Voltage Security Analysis (VSA)

Powerflow based steady-state assessment to determine the voltage stability for generation to generation real power transfers while maintaining constant loads under different powerflow initial conditions, i.e. no outages, multiple outages.

Voltage Security Assessment Tool (VSAT)

³ Ibid, 2, Section 6.2.2, page 6-2.

⁴ Electric Power Research Institute, “EPRI Power system Dynamics Tutorial”, EPRI, Palo Alto, CA. 2009. 1016042, available at www.epri.com, Section 6.2.2, page 6-1.

Powertech Labs, Inc., DSATools, VSAT is a highly automated analysis tool designed for a comprehensive voltage security assessment using powerflow-based steady-state methods.⁵

Wind Integration Study (WIS)

A SPP system study that evaluates the impact of wind penetration and identifies system breakpoints.

⁵ Powertech Labs, Inc., Dynamic Security Assessment Software (DSATools), [Voltage Security Assessment Tool \(VSAT\)](#).

INTRODUCTION

3.1 BACKGROUND AND OBJECTIVES OF THE STUDY

The Southwest Power Pool (SPP) in 2015 began conducting a study to determine the operational and reliability impacts for integrating variable energy resources into the SPP transmission system. The study required detailed engineering analysis and significant effort to interpret the study results and findings. The study assessed the reliability impacts associated with additional variable energy resources installed within the SPP operating area. SPP studied wind-penetration levels of 30%, 45% and 60%. A voltage-stability analysis indicated renewable penetration levels are approaching current limits. SPP also analyzed wind energy ramping, re-dispatch and outages and steady-state thermal and voltage.

In continuation to the 2015 Wind Integration Study (WIS) SPP began analysis in 2016 on the Variable Generation Integration Study (VIS). The objectives for the VIS are to assess and identify system transient and voltage stability limitations, analyze SPP ramping capabilities, perform load pocket analysis, and assess frequency response.

TRANSMISSION IMPACT STUDY

- Transient Stability Analysis for 45% and 60% wind penetration.
- Frequency Response Analysis for 45% and 60% wind penetration
- Seasonal Voltage Stability Analysis 2017 and 2021
- Seasonal Load Pocket Stability Analysis for 2017 and 2021
- Targeted 5 Minute Future Ramping 5 Year Outlook Analysis

3.2 THE SOUTHWEST POWER POOL

SPP was founded in 1941 with 11 members and after WWII the members companies continue the realized benefits of regional coordination. In 1968 SPP became a NERC regional council and SPP continued to reach a number of milestones as the organization progressed through history. SPP implemented telecommunication networks in 1980; in 1991 SPP implemented the reserve sharing group then implemented reliability coordination in 1997, and tariff administration in 1998. The SPP's most recent achievement occurred in 2014 with the launch of the Integrated Market Place. SPP is a Regional Transmission Organization (RTO) approved by the Federal Energy Regulatory Commission (FERC). As an RTO, SPP ensures the reliability of the transmission system and transmission infrastructure. SPP also, provides competitive wholesale pricing of electricity.

3.3 KEY CHALLENGES FOR THE INTEGRATION OF VARIABLE GENERATION

SPP has already experienced real-time wind penetration levels above 40%. This is projected to significantly increase in the next couple of years. At these high levels of wind penetration, SPP operations must ensure that it is prepared for changes that occur in generation output. SPP currently has a combination of Non-Dispatchable and Dispatchable Variable Energy Resources (NDVER/DVER) installed within the SPP footprint. By maintaining a fleet of NDVERS, it limits available ancillary service capacity and requires thermal resources and DVERs to provide available

capacity for ancillary services. SPP will have 280 MW utility scale solar installed at the end of 2016. The current Generation Interconnection Que has approximately 3000MW. Based on the queue size and historical experience with NDVERs, SPP has worked towards having the necessary governance in place such that costs to solar farms are minimized and incorporated into initial capital investment and install.

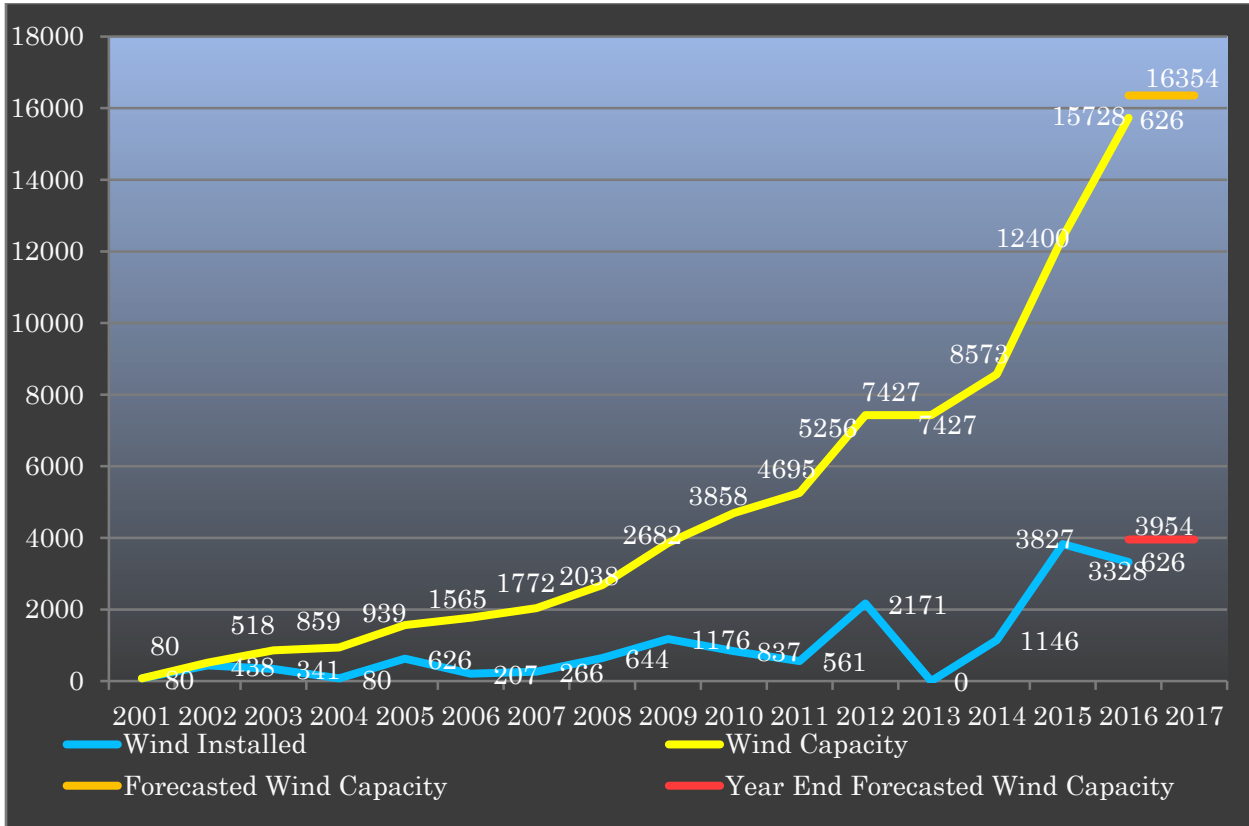

Figure 3.3.1: SPP Wind Installed and Wind Capacity

In 2001 SPP installed 80 MWs of wind generation and has experienced significant wind growth as wind turbine technology has advanced. SPP is one of the leading footprints for wind development in North America, and as the chart indicates SPP has currently installed 15728 MWs, and is projecting to finish 2016 with 16345 MWs of installed capacity.

SPP MODEL DEVELOPMENT

4.1 STEADY STATE MODELING

The topology used for the VIS was developed through the Model Development Working Group (MDWG) which is responsible for maintenance of an annual series of transmission planning models (power flow, short circuit, and stability models) which represent the current and planned electric network of the Southwest Power Pool. It is also responsible for providing NERC with data that supports the models developed by the Multiregional Modeling Working Group (MMWG) and the System Dynamics Database Working (SDDWG). An SPP MDWG Model Development Procedure Manual is publically posted on spp.org.

The desired base models for the VIS analysis consisted of a 2017 and 2021 spring topology with Light load conditions and historical operations transmission and generation outages applied. A total of four models were built with wind dispatched at 45% and 60% of the SPP Light load.

The 2016 Series MDWG models were used to develop the VIS models. Since the MDWG Light load power flow models have the same topology as the spring models, the Light load MDWG models was used to develop the 2016 and 2021Spring VIS models.

TARA PowerGem was used to dispatch the models by applying a Security Constrained Dispatch (SCED) treating SPP as a Consolidated Balancing Authority. The economic data from the 2017 ITP10 was utilized to perform the SCED. The SPP portion of the NERC Book of Flowgates was used initially to constrain the SCED dispatch.

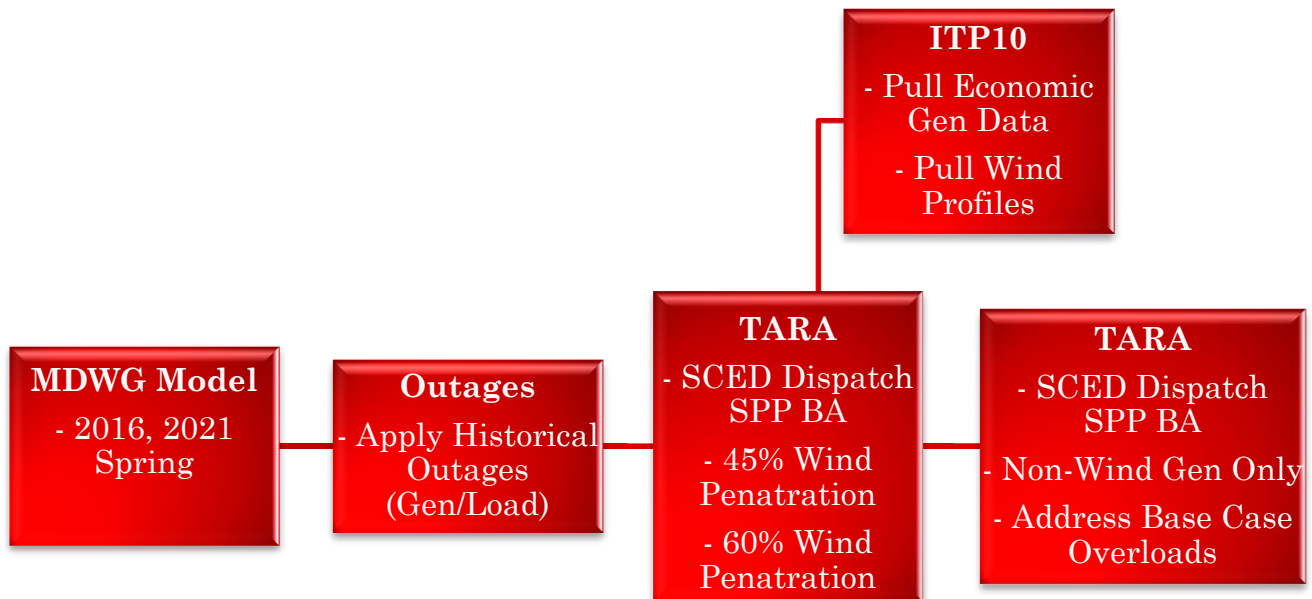

Figure 4.1.1: Process flow for Variable Generation Integration Powerflow Build

The load level for SPP in the 2016 VIS Spring model is about 23.8GW and in the 2021 VIS model is about 24.6GW. A summary of generation output by fuel type is provided in Figure 4.1.2 for each VIS model, and a summary of capacity vs dispatch for each model is provided in Figures 4.1.3 and 4.1.4.

The target wind output at each windfarm was calculated to achieve the total wind output of 10.7GW for the 45% penetration models. The wind output of each windfarm was acquired from the ITP10 and was used as starting point. A ratio was calculated by dividing the 10.7GW target by the total ITP10 wind output. The ITP10 output at each windfarm was multiplied by that ratio to get a target output. This produced an overall wind profile that was very similar to the ITP10 while achieving the desired wind penetration. Wind farms in the offer file used to SCED dispatch in TARA were given zero cost and an economic maximum equal to the calculated target dispatch.

The target wind output at each windfarm was also calculated to achieve the total wind output of over 14GW for the 60% penetration models. The target 14GW was divided by the total SPP wind capacity to get a ratio. The target output at each windfarm was then calculated by multiplying the windfarm maximum capacity by the ratio. This produced a constant capacity factor at each windfarm to achieve the desired wind penetration. Wind farms in the offer file used to SCED dispatch in TARA were given zero cost and an economic maximum equal to the calculated target dispatch.

The average wind capacity factors of the wind dispatched is about:

- 45% VIS models – 70% Capacity Factor
- 60% VIS models – 91% Capacity Factor

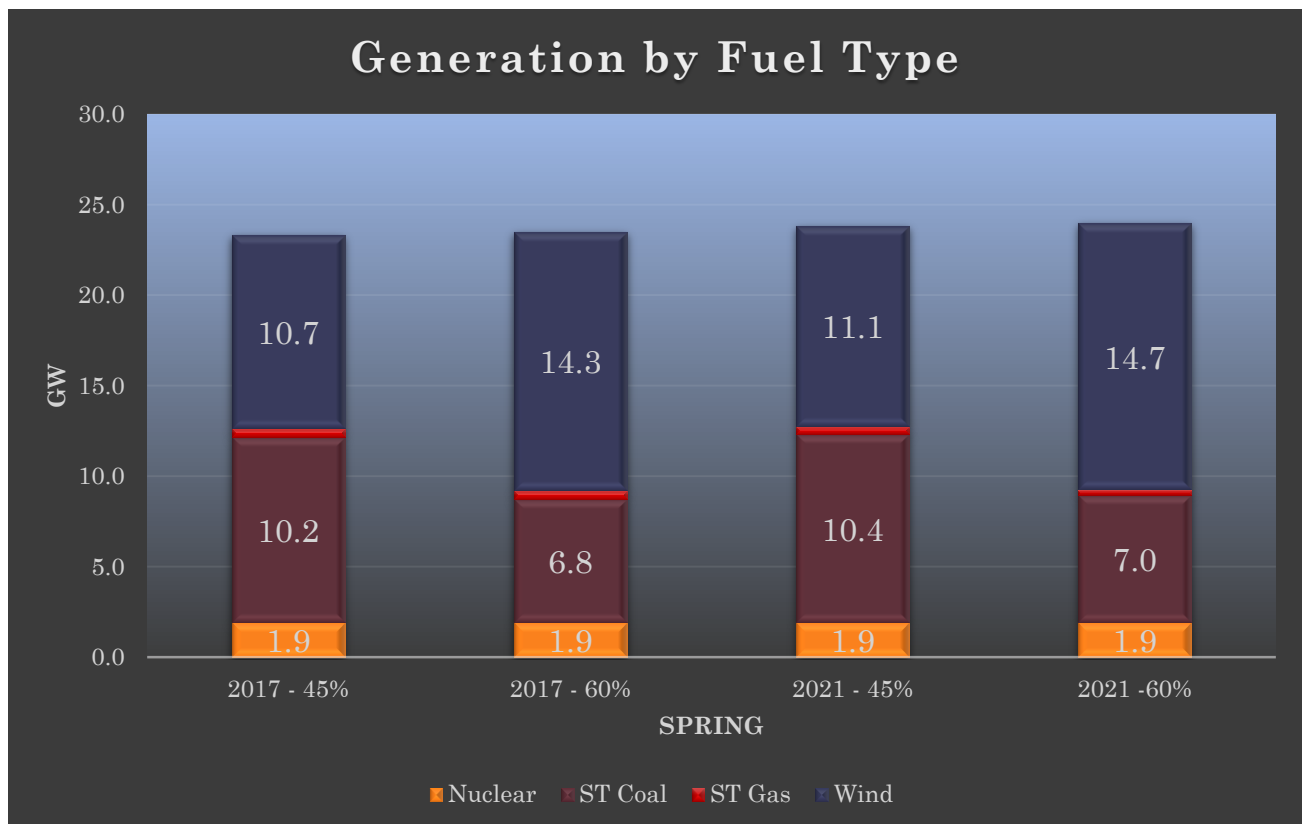

Figure 4.1.2: Generation Output Fuel Summary

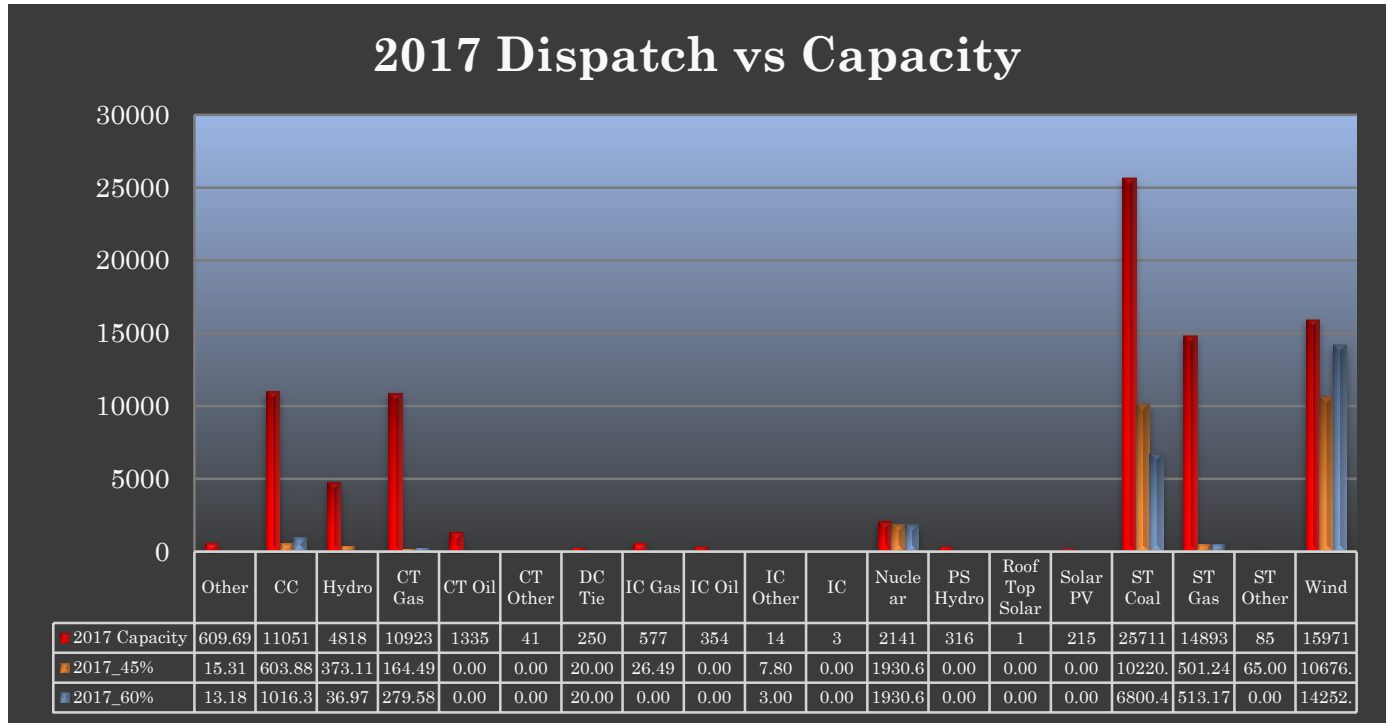

Figure 4.1.3: 2017 Dispatch vs Capacity

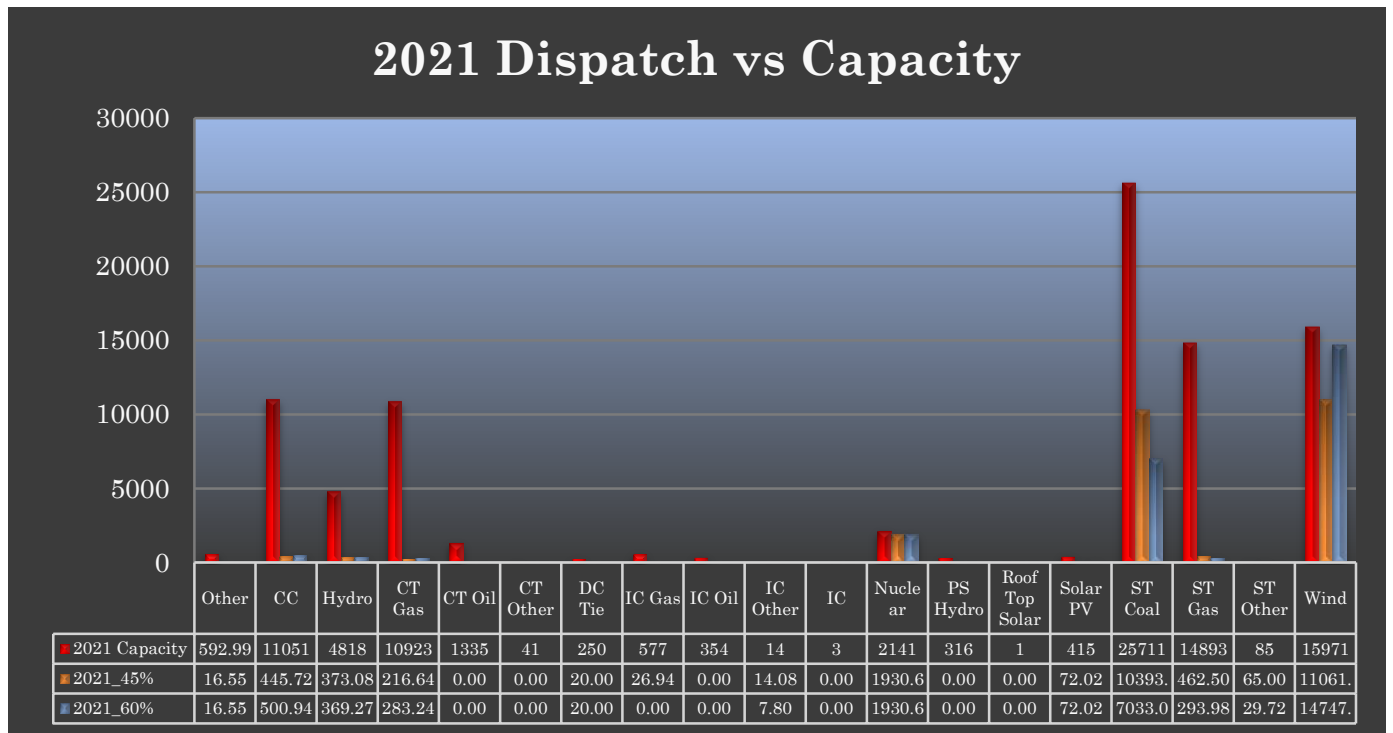

Figure 4.1.4: 2021 Dispatch vs Capacity

4.2 VIS OUTAGE SUMMARY

The date chosen to capture outages for the VIS model build was April 5, 2016. Figures 4.1.5 and 4.1.6 summarize the number of transmission outages and generation outages that were applied to each VIS model. The high side transformer voltage was used to count the number of transformer outages and generator step up transformers were included in the summary.

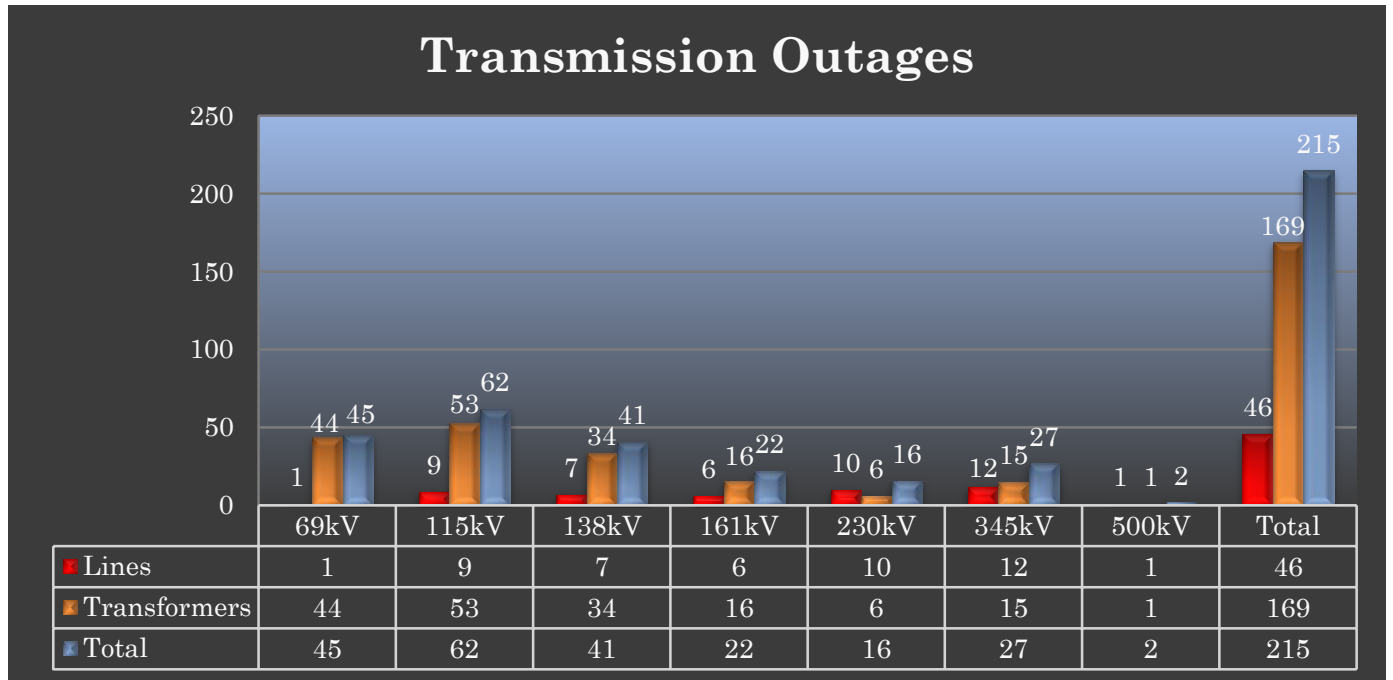

Figure 4.1.5: Transmission Outage by Voltage Level

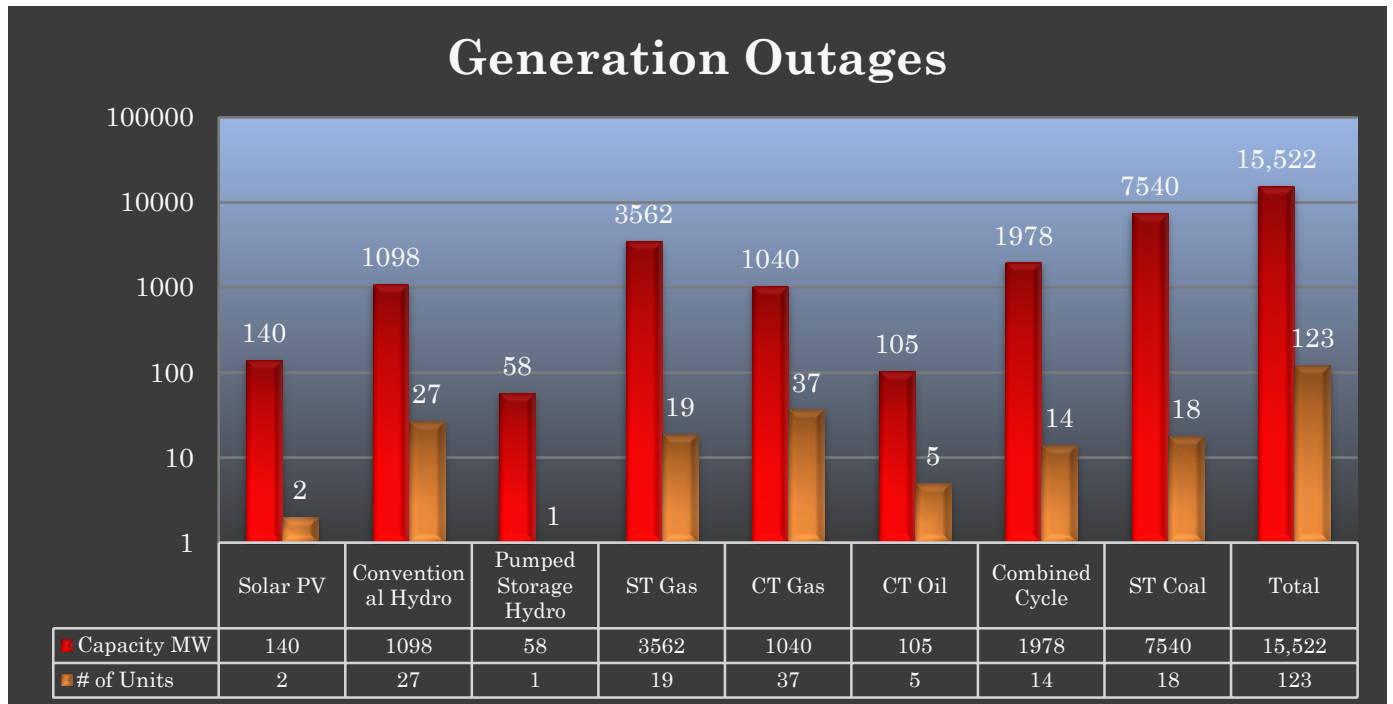

Figure 4.1.6: Generation Outages by Fuel Type

4.3 DYNAMICS MODELING

The SPP MDWG Dynamic Cases are a coordinated effort between NERC registered entities within the SPP PC and SPP Staff to build a set of Dynamic Ready Cases. Updated dynamic power flow data and dyre file model information from NERC registered entities within the SPP PC is assembled using the Final SPP MDWG Build Power Flow Cases. Dyre files contain a group of flat text file representations that defines the location in the network (by bus, machine, load, dc line, etc.) of a dynamic equipment model from the PSSE Model Library, along with the constant parameters of the equipment model. The PSSE Model Library contains data sheets for each of the equipment models in the PSSE model library. These dynamic ready cases are used to support the SPP TPL Study, GI Studies, and the MMWG Dynamic Case Build. The 2016 Light Load dynamic ready 2016 Series MDWG model was used to develop the VIS dynamic study cases. The dispatch from the 2016 Wind Integration Study spring models was applied to develop wind penetration levels at 30%, 45% and 60% of SPP load. The outages from the 2016 Wind Integration Study spring model were also applied to each wind scenario.

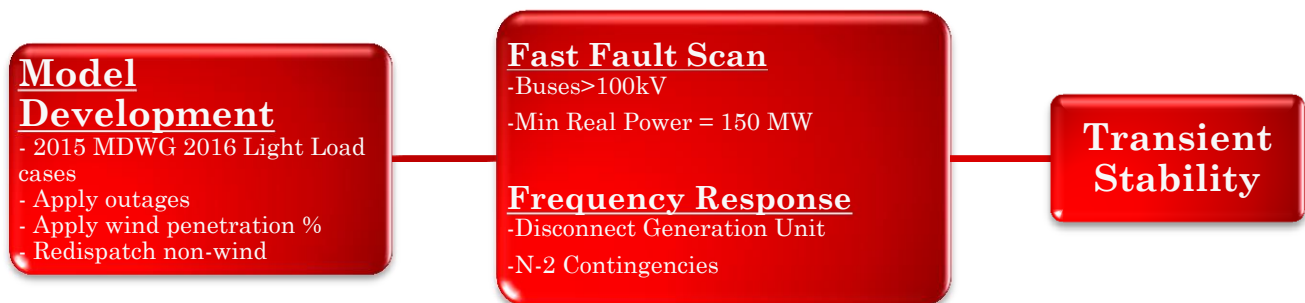

Figure 4.3.1: Process flow for Transient Stability and Frequency Response

TRANSIENT STABILITY ANALYSIS FOR 45% AND 60% WIND PENETRATION

5.1 OVERVIEW AND OBJECTIVE

A transient stability study was performed to assess system stability for the 45% and 60% wind penetration 2016 Light Load cases (ops outages included) for a loss of generation event. Stability analysis was completed using DSATools TSAT. During the stability simulations, monitored parameters included rotor angle, speed, real and reactive power for bus voltages greater than 100kV in the disturbance area, transient voltage response, and machine rotor angle damping. Parameter values were compared with the *SPP Disturbance Performance Requirements* criteria.

5.2 DEFINITIONS

5.2.1 Transient Stability

Transient Stability (rotor angle stability) refers to the ability of synchronous machines of an interconnected power system to remain in synchronism after being subjected to a disturbance [19]. It depends on the ability to maintain/restore equilibrium between electromagnetic and mechanical torque of each synchronous machine in the power system. It is basically generator stability.

Once a disturbance on the system occurs, the system generators oscillate over the transient time frame of up to 20 seconds similar to Figure 5.2.1. If any generators lose stability, their rotor angles will respond similar to the brown and pink traces. The blue one remains stable. Physically speaking, the unstable generators lose their magnetic bonds and will be disconnected from the system.

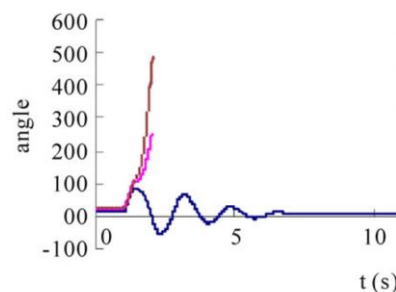

Figure 5.2.1: Rotor Angle Stability

Transient stability depends on the operating conditions of the system, the dynamic characteristics of the system devices, and the severity of the disturbance. Other drivers are system inertia, generator loading, and fault clearing time.

5.2.2 Oscillation Damping

Oscillation Damping – is an influence within or upon an oscillating system that has the effect of reducing, restricting or preventing its oscillations. In the context of the present study, damping is the decay of disturbance induced rotor oscillations and is caused by mechanical energy loss in the generator rotor.

The rate of decay of the amplitude of oscillation is expressed in terms of the damping ratio ζ . The damping ratio describes how rapidly system oscillations decay subsequent to a disturbance. It provides a mathematical means of expressing the level of damping in a system relative to critical damping. A smaller damping ratio implies a slower decay rate, and underdamped systems oscillate for longer times.

For an oscillatory mode (pattern) represented by a complex eigenvalue $\alpha + j\beta$, the damping ratio is given by:

$$\zeta = (-\alpha / \sqrt{\alpha^2 + \beta^2})$$

An example is used to show how the above calculation can be used to visualize oscillatory behavior patterns. Consider two modes, both at 1 Hz, but with different damping (3% and 5% respectively). The two modes are revealed in the time domain and the frequency domain as shown in Figure 2.

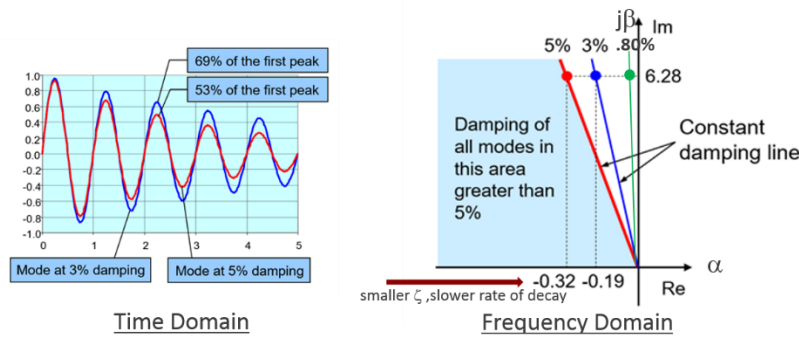

Figure 5.2.2: Oscillation Damping

Notice that as the damping ratio gets smaller, a slower rate of decay occurs. The green point is SPP’s damping ratio criteria $\zeta=0.8\%$, meaning any oscillatory modes represented by complex eigenvalues on the left of the green line is deemed acceptable.

5.2.3 Transient Voltage Response

Transient Voltage Response (Short-term voltage stability) – involves dynamics of fast-acting power system components such as induction motors, electronically controlled loads and HVDC converters. The study period of interest is in the order of several seconds, and analysis requires solutions of appropriate system differential equations; that is similar to the analysis of rotor angle stability. Dynamic modeling of loads is often essential. In contrast to rotor angle stability, short circuits near loads are important.

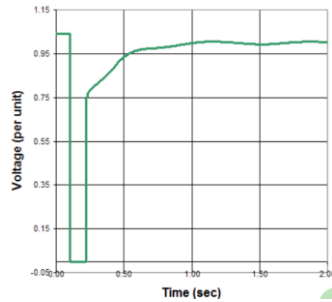

Figure 5.2.3: Transient Voltage Response

Transient voltage response describes the way in which the voltage responds before, during, and after the fault and its subsequent clearing. Much can be understood about the underlying electric power system and its voltage stability when analyzing the voltage response. Depending on the proximity to the fault, Figure 5.2.3 shows how the voltage drops and remains very low during the fault and returns to steady state after a given time period. This period of time between fault clearing and return to steady state provides insight into the underlying reactive power supply.

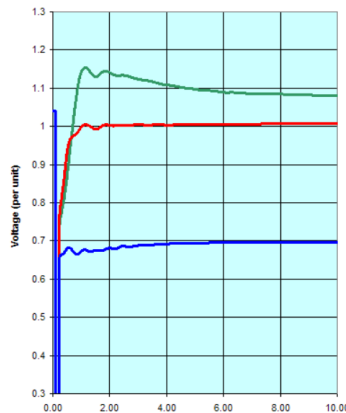

Figure 5.2.4: Various Transient Voltage Responses

Figure 5.2.4 shows the various responses that may be observed when studies are performed. As shown, the green response overshoots the pre-fault voltage and settles over time to steady state. This indicates there is more than adequate reactive power in the vicinity. The red response has no overshoot and settles quickly to steady state due primarily to the characteristics of the load as well as adequate reactive power supply. The blue response quickly settles to a low steady state voltage indicating there is no access to reactive power to recover the voltage to within acceptable limits. It should be noted the shape of the transient voltage response curves is consistent over a given area of the grid. Other curve shapes may be dominant in other areas, load pockets, etc.

SPP’s Disturbance Performance Requirements outline the transient voltage response criteria that must be met at every SPP bus greater than 100kV during the simulations: *“After a disturbance is cleared; bus voltages on the Bulk Electric System shall recover above 0.70 per unit, 2.5 seconds after the fault is cleared. Bus voltages shall not swing above 1.20 per unit after the fault is cleared, unless affected transmission system elements are designed to handle the rise above 1.2 per unit.”*

5.3 STABILITY ANALYSIS MODELS AND DATA

SPP 2015 MDWG 2016 Light Load model with 45% and 60% wind penetration and operations outages and dynamics data were provided to Powertech, Labs Inc. for the case build. 1st generation generic wind farm models (Type 3 and Type 4 only) and proprietary models were replaced with 2nd generation generic models for use in the simulations. The cases were initialized and delivered to SPP for the study. Twenty (20) second time domain simulations using Powertech Labs DSATools TSAT were performed for all N-2 events described in later sections of this report. Rotor angle stability and oscillation damping was monitored for all generators within SPP’s footprint. Transient voltage response was monitored for all SPP BES buses.

5.3 ANALYSIS

The analysis was accomplished in two steps:

5.3.1 Step 1: FFS Screening

V&R Energy’s FFS tool was used to perform the screening. The tool screens potential transmission fault locations for grid stability analysis and quickly identifies the most severe fault locations and ranks them in the order of severity. The tool begins by identifying the most severe fault locations, above 100 kV, which are considered the weaker points in the network. Faults at each of the identified locations are then ranked according to severity using a Ranking Index (RI) for the loss of lines, transformers, or generators at each ranked bus.

Once the RI is known, the CCT is computed. The CCT is the maximum time during which a disturbance can be applied without generator units becoming unstable. SPP classifies fault severity according to the Ranking Index (RI) and the Critical Clearing Time (CCT).

515 SWPA	531 MIDW	545 INDN
520 AEPW	534 SUNC	546 SPRM
523 GRDA	536 WERE	640 NPPD
524 OKGE	540 GMO	645 OPPD
525 WFEC	541 KCPL	650 LES
526 SPS	542 KACY	652 WAPA
527 OMPA	544 EMDE	

Table 5.3.1: Fast Fault Screening Areas

To elaborate on how the FFS faults are tested, a line is initially open at a bus and a fault is then applied near the bus on a second line. With the FFS tool, a critical clearing time is calculated by

opening the second bus to clear the fault. The FFS tool continues the process at every bus to find the most severe location.

Table 5.3.2 summarizes the results of the Fast Fault Screen for the 45% and 60% wind penetration cases. One potentially severe location was determined for the 45% case and four potentially severe locations for the 60% case. The actual fault clearing times were verified with the owner of the faulted buses.

Model	Bus	Fault Location	Area Number	Area Name	Ranking Index	FFS Critical Clearing Time (Cycle)	Owner Specified Clearing Time (Cycle)	Outage Element
45%	532797	Wolf Creek 345kV	536	WERE	18.673	0.6*	3.6	Wolf Creek – RoseHill 345kV Line
								Wolf Creek – Waverly 345kV Line
60%	507454	Turk 138kV	520	AEPW	21.208	4.8	5.0	Turk – Okay 138 kV Line
								Turk 138/345kV Transformer
60%	510406	N.E.S 345kV	520	AEPW	19.085	8.4	4.0	N.E.S – Oneta 345kV Line
								N.E.S – Tulsa North 345 kV Line
60%	532797	Wolf Creek 345 kV	536	WERE	18.285	0.6*	3.6	Wolf Creek – RoseHill 345kV Line
								Wolf Creek – Waverly 345kV Line
60%	532799	Waverly 345kV	536	WERE	14.860	4.8	4.6	Waverly – LaCygne 345kV Line

Table 5.3.2: Fast Fault Screening Results

Note*: The models used by the FFS included no Operating Directive generation adjustment

5.3.2 Step 2: Stability Analysis

Transient stability analysis was performed on the FFS ranked contingencies having a critical clearing time of less than nine (9) cycles using the “outaged branches” identified in the FFS. The FFS identified the fault bus and associated “outaged branches;” however, the fault sequence was determined by SPP through discussions with members about actual clearing times.

The locations determined from the FFS were used to develop disturbance events for time domain analysis. Figure 5.3.3 gives a graphic representation of the typical event sequences used and Table 5.3.4 provides the event descriptions.

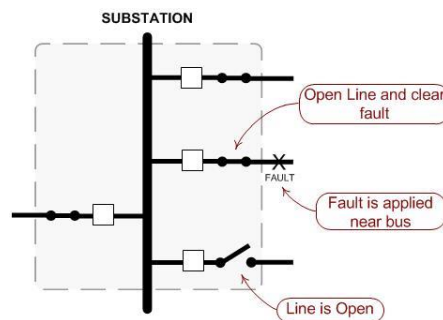

Figure 5.3.3: Event Sequence

Stability analysis was completed using DSATools TSAT software using a 20 second time domain simulation of the disturbance. Tables 5.3.4 and 5.3.5 provide description of studied events based on the FFS and the time domain stability study results.

Model	Bus	Fault Location	Owner Specified Clearing Time (Cycle)	Event Description	Result
45%, 60%	532797	Wolf_Creek 345kV	3.6	Outage Wolf Creek – Rose Hill 345kV Line. Reduce Wolf Creek Generation to 800 MW. Three phase fault near Wolf Creek 345kV bus for 3.6 Cycles. Open Wolf Creek – Waverly 345kV line to clear the fault.	Generators Stable, System Secure
60%	507454	Turk 138kV	5.0	Three phase fault near Turk 138kV bus for 5.0 Cycles. Open Turk – Okay 138kV line and Turk 345/138/13.8kV three phase transformer to clear the fault.	Generators Stable, System Secure. See Figure 5.4.1
60%	510406	N.E.S 345kV	4.0	Three phase fault near N.E.S 345kV bus for 4.0 Cycles. Open N.E.S – Oneta 345kV line and N.E.S – Tulsa North 345kV Line to clear the fault.	Generators Stable, System Secure. See Figure 5.4.2
60%	532799	Waverly 345kV	4.6	Reduce Wolf Creek Generation to 800 MW. Three phase fault near Waverly 345kV bus for 4.6 Cycles. Open Waverly – LaCygne 345kV Line to clear the fault.	Generators Stable, System Secure.

Table 5.3.4: Transient Stability Event Description and Results

The current Operating Directive at Wolf Creek requires generation to be reduced to 800MW when one 345kV line providing Wolf Creek outlet is out of service. This directive extends to the Waverly contingency as well. The system exhibits transient stability and overall security with the Operating Directive in-effect; however, additional transient stability sensitivities were performed for the Wolf Creek and Waverly contingencies to determine the generation level at Wolf Creek equating to critical clearing times for these 45% and 60% wind penetration cases. Table 5.3.5 provides a summary of results.

Model	Fault Location	Bus Name	Owner Specified Clearing Time (Cycles)	Pre-Fault Wolf Creek Generation Output	Summary of Results
45%	532797	Wolf Creek 345 kV	3.6	800 MW	<u>Secure.</u> See Figure 5.4.3
45%	532797	Wolf Creek 345 kV	3.6	900 MW	<u>Secure.</u> See Figure 5.4.4
45%	532797	Wolf Creek 345 kV	3.6	1000 MW	<u>Secure.</u> Poorly damped oscillations occur. See Figure 5.4.5
45%	532797	Wolf Creek 345 kV	3.6	1100 MW	<u>Insecure.</u> Damping Ratio of <u>0.39% is a violation</u> of the 0.8% criteria. See Figure 5.4.6
60%	532797	Wolf Creek 345 kV	3.6	800 MW	<u>Secure.</u> Damping Ratio of 1.68% is a near violation of the 0.8% criteria. See Figure 5.4.7
60%	532797	Wolf Creek 345 kV	3.6	900 MW	<u>Secure.</u> Damping Ratio of 1.42% is a near violation of the 0.8% criteria. See Figure 5.4.8

60%	532797	Wolf Creek 345 kV	3.6	1000 MW	<u>Insecure.</u> Damping Ratio of 0.94% is a near violation of the 0.8% criteria. 17 bus voltage criteria violations. See Figure 5.4.9
60%	532797	Wolf Creek 345 kV	3.6	1100 MW	<u>Insecure.</u> Wolf Creek unstable. Peak-to-Peak angle threshold of 90° violated at 8 generators. 1929 bus voltage criteria violations, voltage collapse. See Figure 5.4.10
60%	532799	Waverly 345kV	4.6	800 MW	<u>Secure.</u> Damping Ratio of 3.27% is a near violation of the 0.8% criteria. See Figure 5.4.11
60%	532799	Waverly 345kV	4.6	900 MW	<u>Secure.</u> Damping Ratio of 1.91% is a near violation of the 0.8% criteria. See Figure 5.4.12
60%	532799	Waverly 345kV	4.6	1000 MW	<u>Secure.</u> Damping Ratio of 2.27% is a near violation of the 0.8% criteria. See Figure 5.4.13
60%	532799	Waverly 345kV	4.6	1100 MW	<u>Secure.</u> Damping Ratio of 1.75% is a near violation of the 0.8% criteria. See Figure 5.4.14

Table 5.3.5: Wolf Creek & Waverly Transient Stability Analysis Results

5.4 RESULTS

All machines for all contingencies exhibited transient stability and all bus voltages were within tolerances (sensitivities excluded). The Wolf Creek and Waverly contingencies allow for higher levels of generation at Wolf Creek than shown in the Operating Directive, but arise at the expense of poor and unacceptable damping. The following figures demonstrate rotor angle responses with oscillation damping and voltage responses.

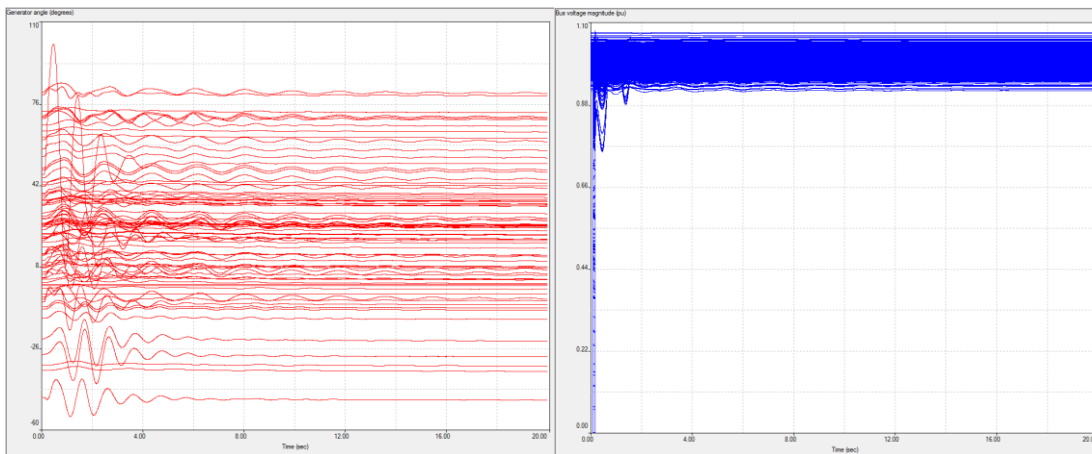

Figure 5.4.1: Rotor Angle and Voltage Response – 60% Turk

The rotor angle response plot in Figure 5.4.1, left exhibits good damping for all generators inside the SPP footprint under fault conditions at the Turk facility for the 60% wind penetration case.

The plot in Figure 5.4.1, right shows all bus voltages returning to within the acceptable range of .7 – 1.2p.u. well before the 2.5 second threshold.

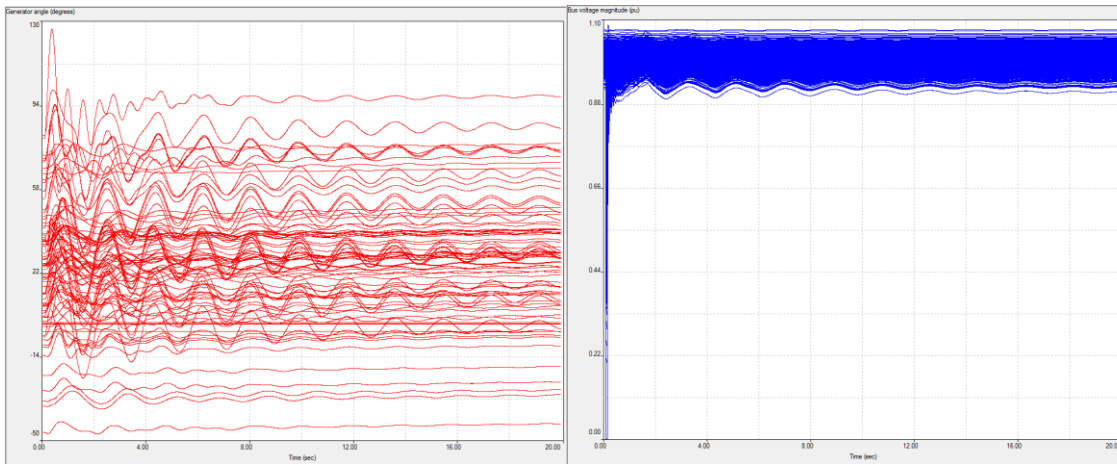

Figure 5.4.2: Rotor Angle and Voltage Response – 60% N.E.S.

The rotor angle response plot in Figure 5.4.2, left exhibits good damping for all generators inside the SPP footprint under fault conditions at the N.E.S. facility in the 60% wind penetration case. The plot in Figure 5.4.2, right shows all bus voltages returning to within the acceptable range .7 – 1.2p.u. well before the 2.5 second threshold.

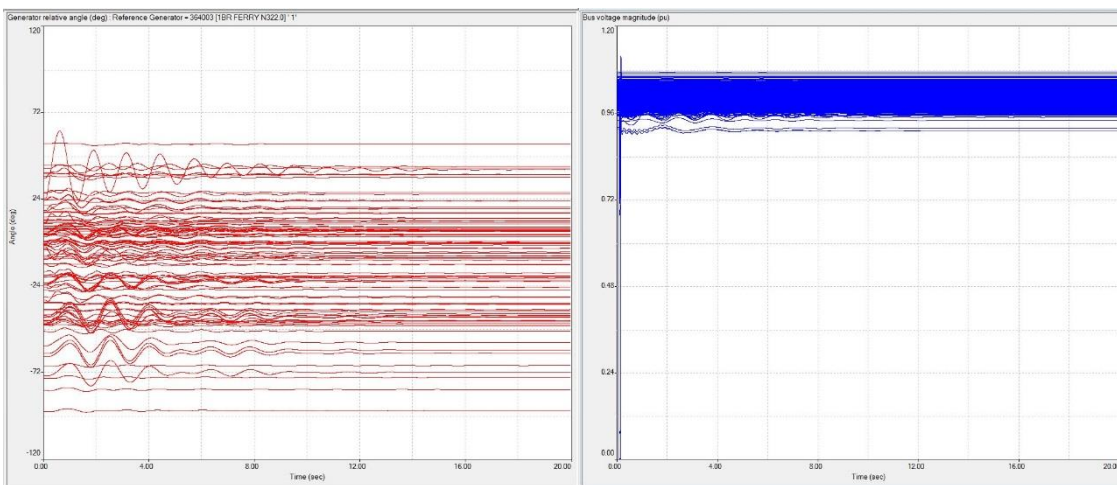

Figure 5.4.3: Rotor Angle and Voltage Response – 45% Wolf Creek at 800 MW

The rotor angle response plot in Figure 5.4.3, left exhibits good damping for all generators inside the SPP footprint under fault conditions at the Wolf Creek 345kV facility with Wolf Creek generation at 800MW in the 45% wind penetration case. The plot in Figure 5.4.3, right shows all bus voltages returning to within the acceptable range .7 – 1.2p.u. well before the 2.5 second threshold.

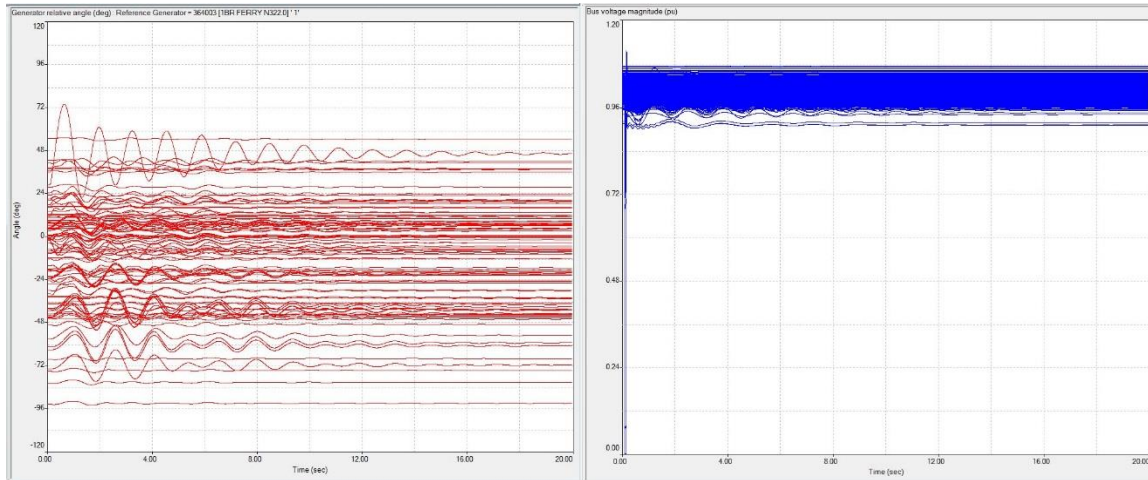

Figure 5.4.4: Rotor Angle and Voltage Response – 45% Wolf Creek at 900 MW

The rotor angle response plot in Figure 5.4.4, left exhibits good damping for all generators inside the SPP footprint under fault conditions at the Wolf Creek facility with Wolf Creek generation at 900MW in the 45% wind penetration case. The plot in Figure 5.4.4, right shows all bus voltages returning to within the acceptable range .7 – 1.2p.u. well before the 2.5 second threshold.

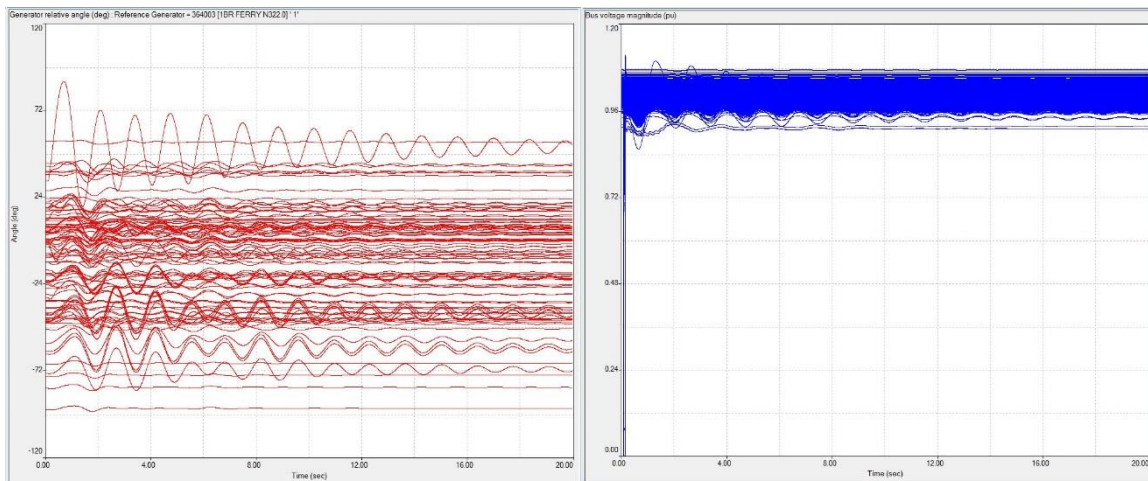

Figure 5.4.5: Rotor Angle and Voltage Response – 45% Wolf Creek at 1000 MW

The rotor angle response plot in Figure 5.4.5, left exhibits good damping for all generators inside the SPP footprint under fault conditions at the Wolf Creek facility with Wolf Creek generation at 1,000MW in the 45% wind penetration case. It is noted that oscillation damping of some generators has worsened with the increased Wolf Creek output. The plot in Figure 5.4.5, right shows all bus voltages returning to within the acceptable range .7 – 1.2p.u. well before the 2.5 second threshold. The voltages are beginning to oscillate as well.

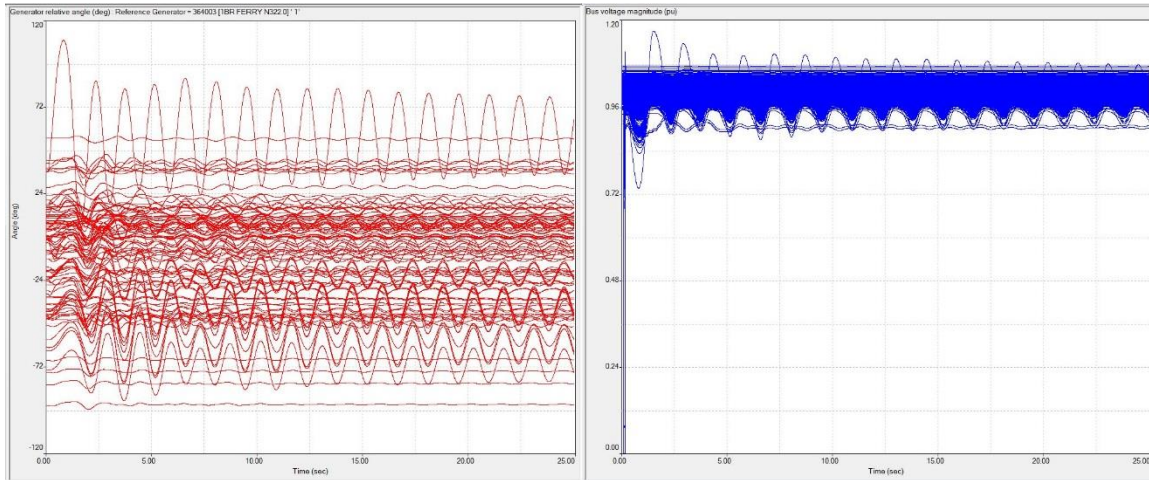

Figure 5.4.6: Rotor Angle and Voltage Response – 45% Wolf Creek at 1100 MW

The rotor angle response plot in Figure 5.4.6, left with Wolf Creek generation at 1,110 MW exhibits unacceptable damping as the 0.8% criteria was violated during the given fault at Wolf Creek 345kV. The damping ratio in this case is 0.39%, causing the system to be insecure. The plot in Figure 5.4.6, right shows all bus voltages returning to within the acceptable range .7 – 1.2p.u. well before the 2.5 second threshold, however voltage oscillations have worsened. Any further increase in Wolf Creek generation will cause Wolf Creek to be unstable.

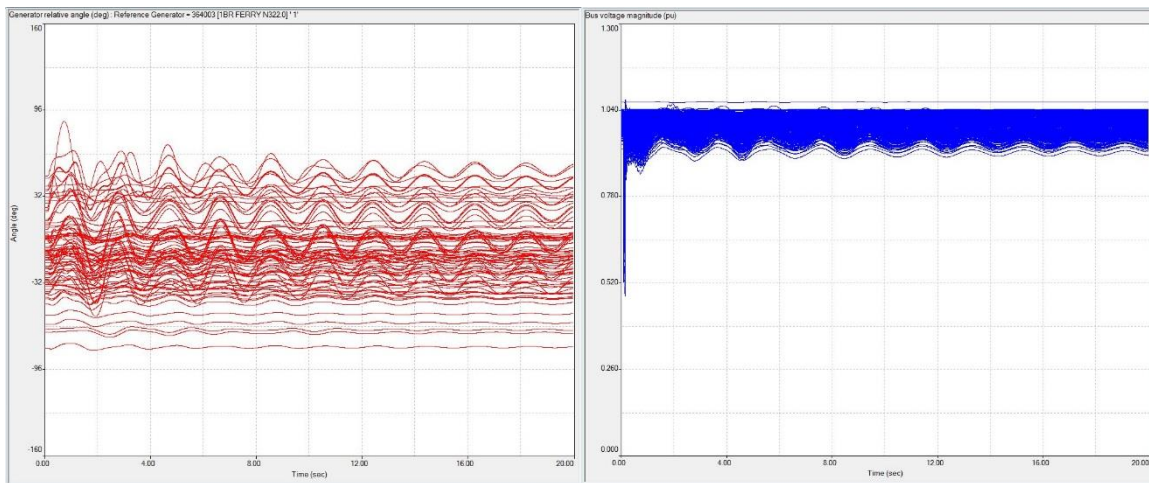

Figure 5.4.7: Rotor Angle and Voltage Response – 60% Wolf Creek at 800 MW

The rotor angle response plot in Figure 5.4.7, left exhibits poor damping for most generators in the SPP footprint during the given fault at Wolf Creek 345kV while Wolf Creek was generating 800MW within the 60% wind penetration case. The resulting damping ratio of 3.27% is a near violation of the 0.8% criteria. The plot in Figure 5.4.7, right shows all bus voltages returning to within the acceptable range .7 – 1.2p.u. well before the 2.5 second threshold.

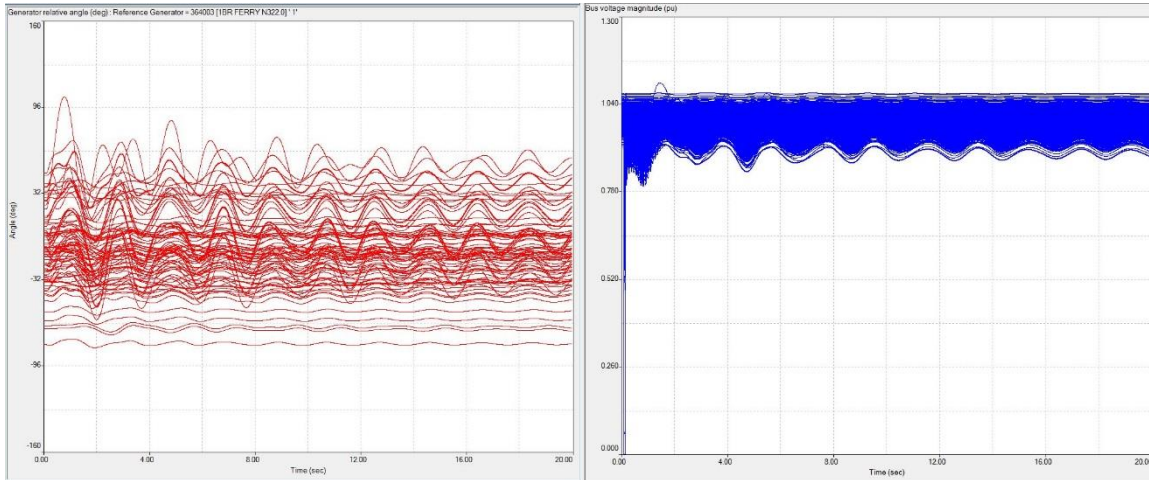

Figure 5.4.8: Rotor Angle and Voltage Response – 60% Wolf Creek at 900 MW

The rotor angle response plot in Figure 5.4.8, left shows deteriorating damping for most generators in the SPP footprint during the given fault at Wolf Creek 345kV with Wolf Creek generation at 900MW’s in the 60% wind penetration case. The Damping Ratio of 1.42% is a near violation of the 0.8% criteria as. The plot in Figure 5.4.8, right shows all bus voltages returning to within the acceptable range .7 – 1.2p.u. well before the 2.5 second threshold.

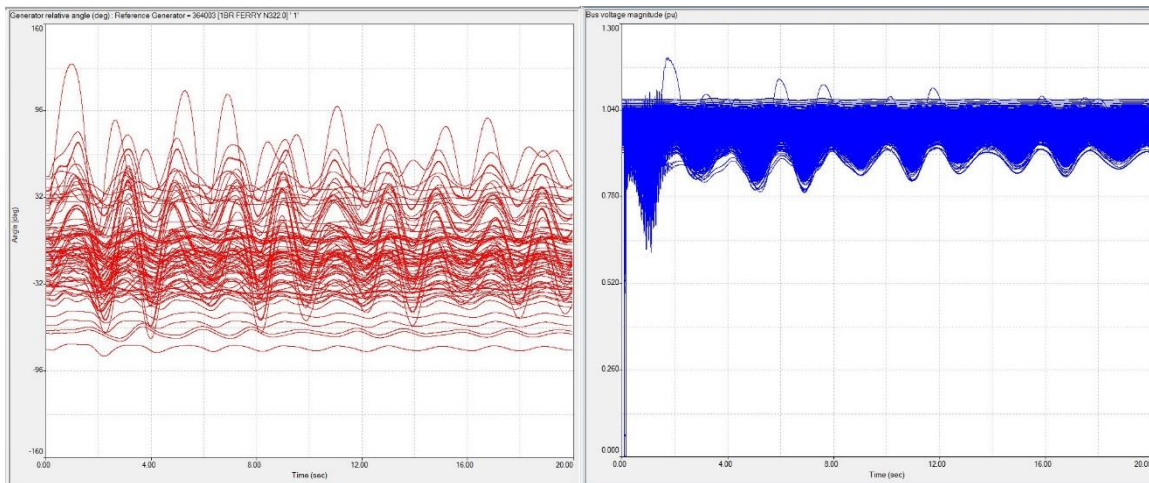

Figure 5.4.9: Rotor Angle and Voltage Response – 60% Wolf Creek at 1000 MW

The rotor angle response plot in Figure 5.4.9, left shows continued deterioration of damping of most generators in the SPP footprint for the given fault at Wolf Creek 345kV with Wolf Creek generation at 1,000MW in the 60% wind penetration case. The Damping Ratio of 0.94% is a near violation of the 0.8% criteria. The plot in Figure 5.4.9, right shows most bus voltages returning to within the acceptable range .7 – 1.2p.u. well before the 2.5 second threshold, however there were 17 bus voltage violations found and increased voltage oscillations are evident. No generators are unstable, however since there were voltage violations, the system is considered to be insecure.

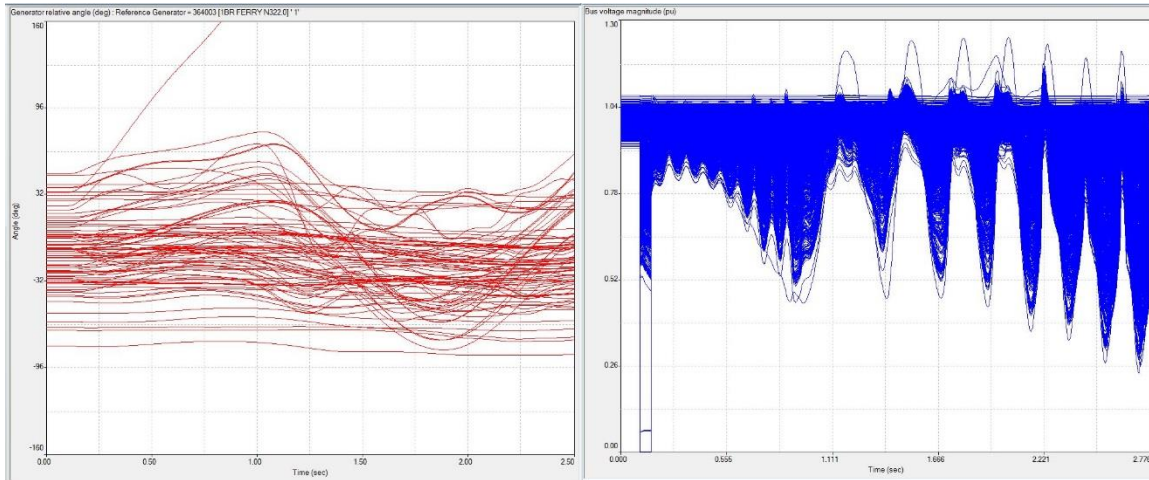

Figure 5.4.10: Rotor Angle and Voltage Response – 60% Wolf Creek at 1100 MW

The rotor angle response plot in Figure 5.4.10, left shows that the Wolf Creek generator is unstable and has lost synchronism. Also, extreme damping deterioration has occurred for a number of generators in the SPP footprint for the given fault at Wolf Creek 345kV with Wolf Creek generation at 1,00MW in the 60% wind penetration case. The plot in Figure 5.4.10, right shows all bus voltages are collapsing. The system is considered insecure.

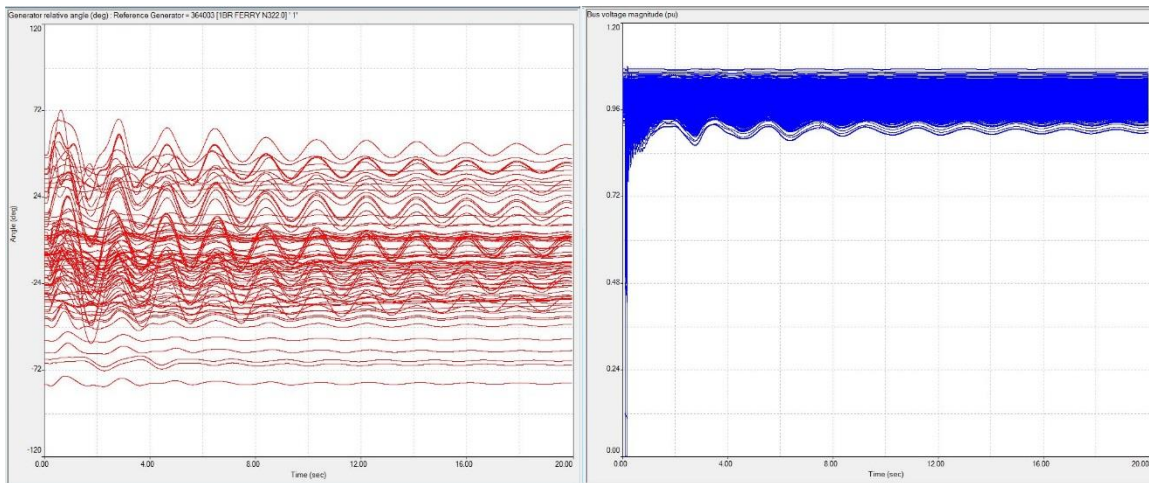

Figure 5.4.11: Machine Rotor Angle – 60% Waverly with Wolf Creek at 800 MW

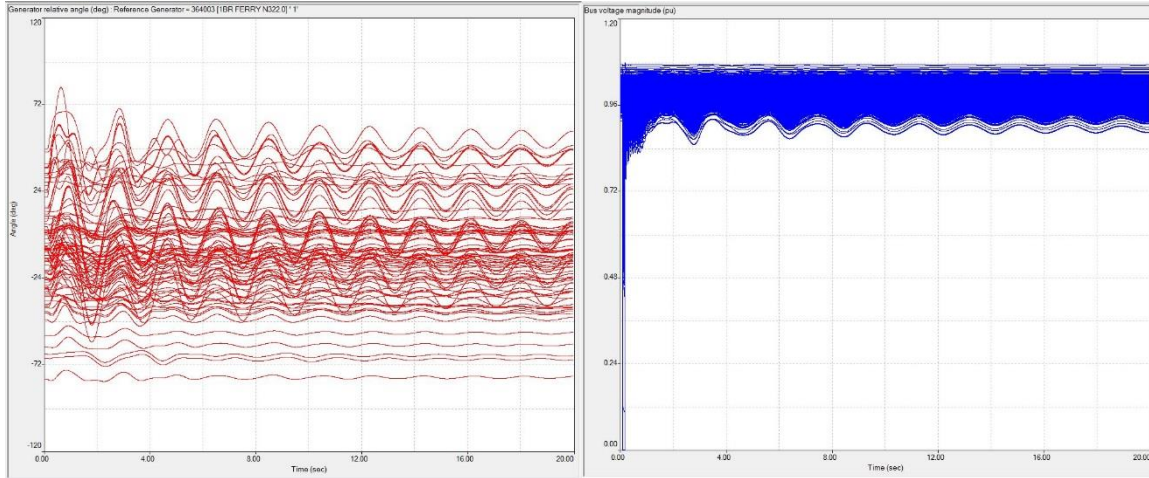

Figure 5.4.12: Machine Rotor Angle – 60% Waverly with Wolf Creek at 900 MW

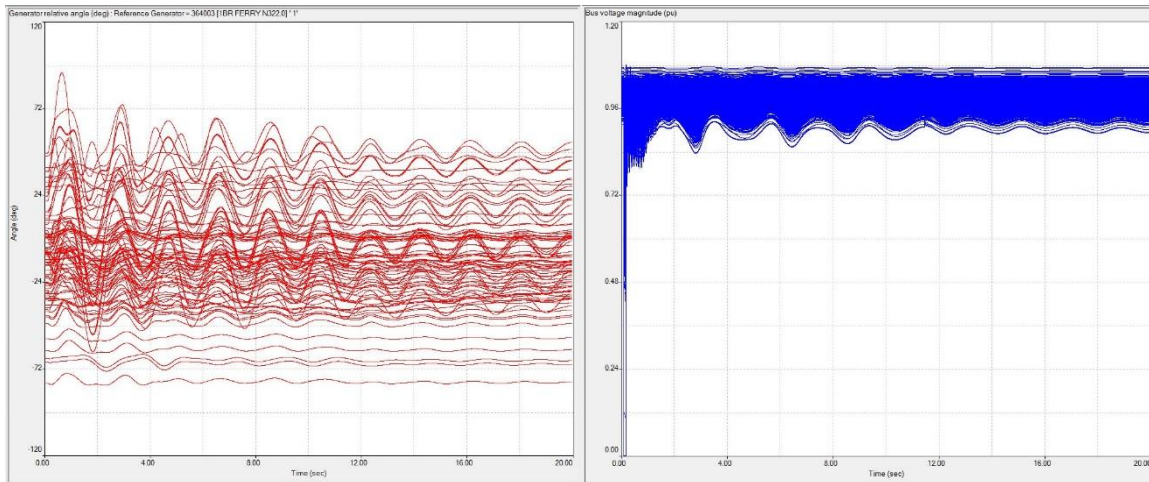

Figure 5.4.13: Machine Rotor Angle – 60% Waverly with Wolf Creek at 1000 MW

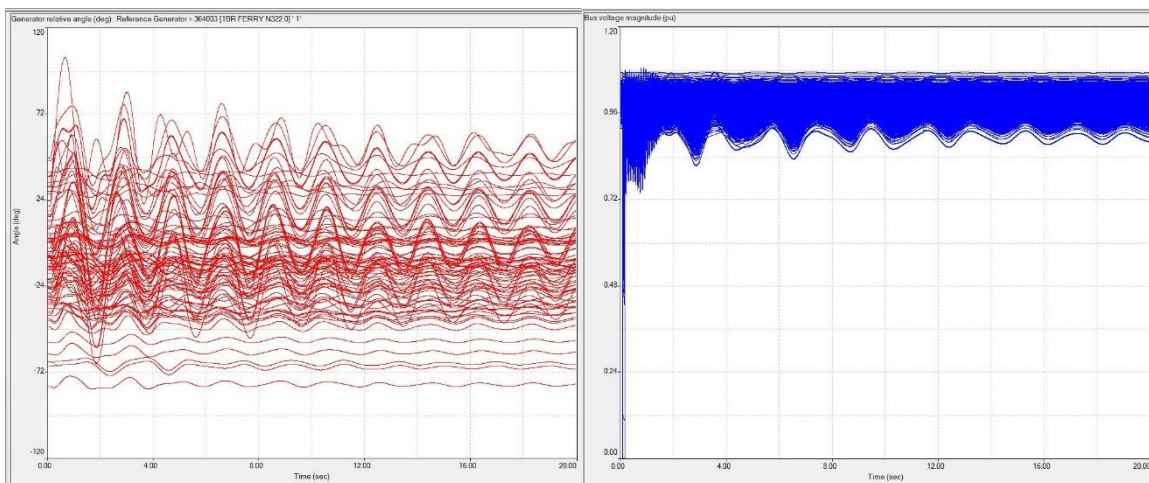

Figure 5.4.14: Machine Rotor Angle – 60% Waverly with Wolf Creek at 1100 MW

As demonstrated in Figures 5.4.11 – 5.4.14, the fault at Waverly 345kV for the 60% case is stable up to 1,100 MW. The figures clearly show and Table 5.3.5 notes as well that very poor damping was

found in all sensitivities for Waverly as the damping ratios were very close to the criteria of 0.8%. Voltages were acceptable in all cases, but with increased oscillation

5.5 CONCLUSION

Results show stability for the 45% and 60% wind penetration for the simulated events. Those simulated Wolf Creek contingencies that preserve the 800MW output Operating Directive are stable but damping is poor. The sensitivities for the Wolf Creek outage indicate that the Wolf Creek output of 1000 MW and 900 MW for the 45% and 60% cases respectively can be accomplished while maintaining system security; however, oscillation damping is dangerously poor in some cases (but within criteria).

In examining the plots and the resulting damping ratios, it is noted that oscillation damping is problematic in many cases. Slow and sustained oscillations indicate excessive stress is occurring at the generators. Oscillations tend to deteriorate with increased output and the machines move closer to instability.

The SPP damping ratio criteria is very low and not in line with the most of the industry, which is 3-5%. It is recommended that the existing Damping Ratio criteria of 0.8% be re-evaluated to ensure that these sustained, slowly damped oscillations are not causing excessive wear and tear on generators when they occur. In general, 0.8% leaves very little margin for system security.

It is also shown that these high wind penetration cases may allow for increased output at Wolf Creek than is noted in the Operating Directive. The 45% case is secure at 1,000 MW, but with poor damping, and the 60% case is secure at 900MW.

FREQUENCY RESPONSE ANALYSIS FOR 45% AND 60% WIND PENETRATION

6.1 FREQUENCY RESPONSE ANALYSIS OVERVIEW

The Southwest Power Pool is experiencing remarkable growth in wind power throughout its footprint. Increased amount of wind power output to serve native load displaces traditional thermal generation. As this is the case, the question naturally arises as to whether this poses problems with frequency response. This section of the study answers this important question and will gauge the success of the reliable integration of new and existing renewable resources.

Significant deviations in frequency are often caused by the tripping of large generation units, which results in substantial real power imbalances. Should the frequency drop below acceptable levels, large blocks of load can be shed, leading to possible cascading outages. Higher levels of wind penetration in the SPP footprint displaces existing conventional generation, thereby changing the overall system inertia. This study will provide insight into the changing dynamics of frequency response due to larger levels of wind penetration.

SPP performed time domain simulation studies of the system frequency behavior following a sudden loss of selected large generating unit(s), with varying amounts of wind generation and operating reserves. The studies performed used the 45% and 60% wind penetration 2016 Light Load cases (ops outages included) and existing MDWG dynamics data for wind turbines. Frequency response was examined and compared to existing under frequency load-shedding set points to determine if the inertial response, the frequency nadir, and the settled frequency following the generation loss event are acceptable. The analysis tested for stability with respect to machine rotor angle, transient voltage response, frequency response, and machine oscillation damping. The frequency response analysis was completed using DSATools TSAT.

6.2 FREQUENCY RESPONSE DEFINITIONS

6.2.1 Frequency Response:

The NERC glossary of terms [21] defines frequency response as “the ability of a system or elements of the system to react or respond to a change in frequency.” Generally speaking, the system generation must equal the system load at all times and when this balance is disturbed, it manifests in a deviation from the nominal 60 Hz power frequency. In the context of this study, the frequency response will be a measure of the ability of the system to react or respond to a frequency decline due to a large loss of generation.

When generation is suddenly removed from the system, the frequency responds similar to the classic curve shown in Figure 6.2.1. The three time periods associated with this response, arresting period, rebound period, and recovery period, correspond to control actions that are taken to cause this response to occur [20].

6.2.2 Arresting Period:

When an unexpected loss of a large conventional generator occurs, the frequency begins to decline immediately. The rate of decline is determined by the total inertia of the remaining system generators/loads and the power output of the disconnected generator. Since inertia is defined as the ability of the power system to resist changes in frequency, a “resistance” to the frequency decline is provided by releasing the kinetic energy of the rotating masses of the remaining generators. This phenomenon is known as the *inertial response*. **Primary frequency control**, considered a fast corrective action and includes governor response and frequency-responsive demand response, is also initiated during the arresting period to assist in arresting the frequency decline. The frequency at which the decline is arrested is known as the *frequency nadir*.

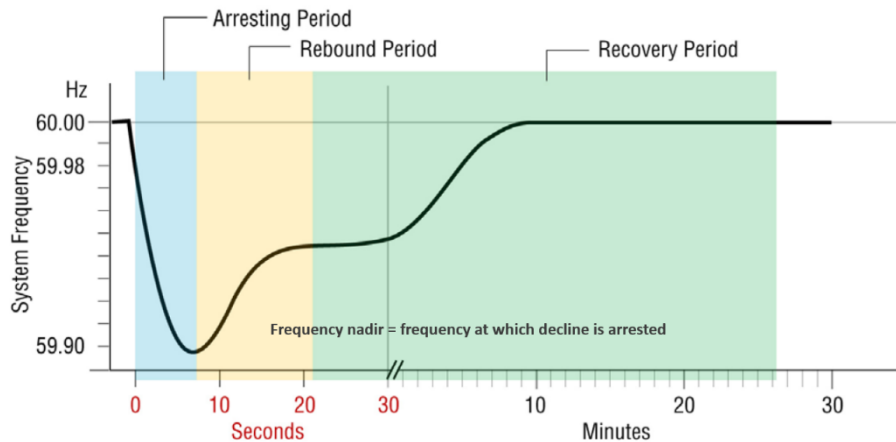

Figure 6.2.1: Classic Frequency Response to Loss of Generation

6.2.3 Rebound Period:

Primary frequency control is the control action taken. As the remaining generator governors adjust to provide more real power output, the frequency begins to increase from its nadir and gradually return toward normal.

6.2.4 Recovery Period:

As the frequency continues to increase, a slower **Secondary Frequency Control** engages until the frequency is fully recovered. Secondary control normally consists of Automatic Generator Control (AGC).

The criteria for determining acceptable frequency response is the NERC Standard PRC-006-2[23], which defines design performance for under frequency load shedding, the standard requires frequencies to remain within the boundaries defined by Attachment 1 in the standard which is shown below in Figure 6.2.2

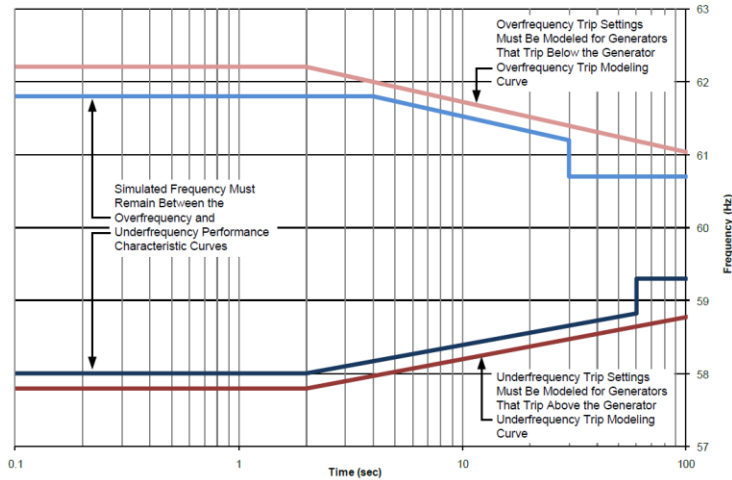

Figure 6.2.2: NERC Underfrequency Load Shedding Curves

6.3 FREQUENCY RESPONSE ANALYSIS

6.3.1 Models and Data:

SPP 2015 MDWG 2016 Light Load model with 45% and 60% wind penetration, operations outages, and dynamics data were provided to Powertech, Labs Inc. for the case build. 1st generation generic wind farm models (Type 3 and Type 4 only) and proprietary models were replaced with 2nd generation generic models for use in the simulations. The cases were initialized and delivered to SPP for the study.

The WECC REPC_A [22] was also added to the model data for all Type 3 and Type 4 generic wind farm models. The REPC_A model can provide primary frequency response in the event of a major frequency disturbance and wind farm manufacturers have included this functionality in newer, existing turbines. Since the study includes the removal of generation from the system to determine frequency response, the model was included to provide support to the system during such an event. Figure 6.3.1 below shows the control block diagram of the REPC_A model. The model senses a low frequency event by continuously calculating an error in frequency. This error translates into an injection of real power by the turbine.

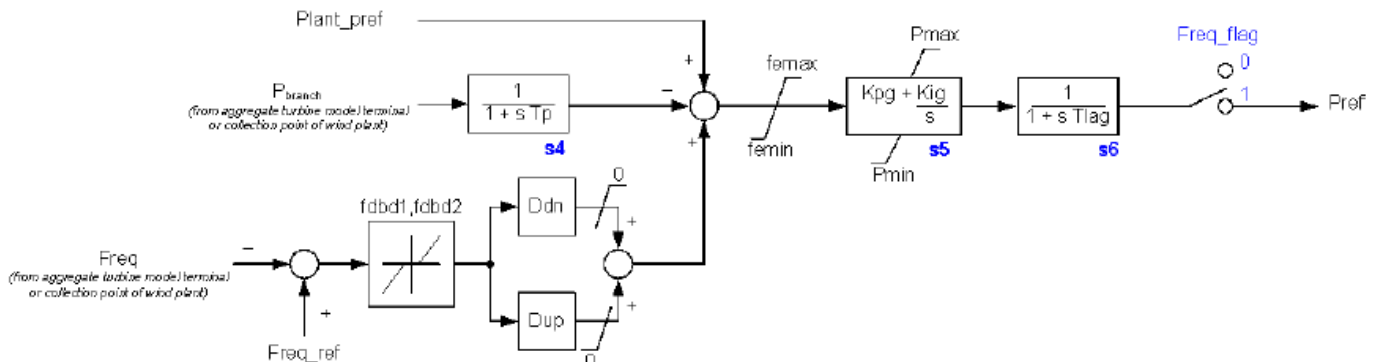

Figure 6.3.1: WECC REPC_A Control Block Diagram

The cases included in the study are shown below in Table 6.3.2:

Case Name	Season Model	Wind Penetration	Operations Outages Included	Frequency Response
Base Case 45%	2016 Light Load	45%	Yes	REPC_A off
Change Case 45%	2016 Light Load	45%	Yes	REPC_A on
Base Case 60%	2016 Light Load	60%	Yes	REPC_A off
Change Case 60%	2016 Light Load	60%	Yes	REPC_A on

Table 6.3.2: Study Cases

6.3.2 Analysis:

The frequency disturbance selected for this study was the removal of the 1261 MW Wolf Creek Generation Unit as this was the largest in-service thermal generator in SPP’s footprint in the given models. Frequency response analysis was completed using DSATools TSAT software. Monitored parameters for the analysis included buses greater than 100kV, machine rotor angle, bus frequency, transient voltage response, and machine damping. Table 6.3.3 details the system disturbance used as the contingency event during the simulations.

Seasonal Model	Bus	Unit Name	Unit Type	Event Description
All	532751	Wolf Creek #1	Nuclear	Disconnect 1261 MW Wolf Creek Generation Unit

Table 6.3.3: Study Disturbance

6.3.3 Results:

Twenty (20) second time domain simulations using Powertech Labs DSATools TSAT were performed for the event described in Table 6.3.3. Rotor angle stability and oscillation damping was monitored for all generators within SPP’s footprint. Transient voltage response and Frequency response was monitored for all SPP BES buses.

All machines exhibited rotor angle stability, good oscillation damping, and all bus voltages were within tolerances. The system is deemed secure for all cases with respect to rotor angle stability, oscillation damping, and transient voltage response.

The base cases were tested to determine the system response to determine the response. Bus frequencies in SPP are plotted below in Figure 6.3.4 for the 45% (red) and 60% (blue) cases.

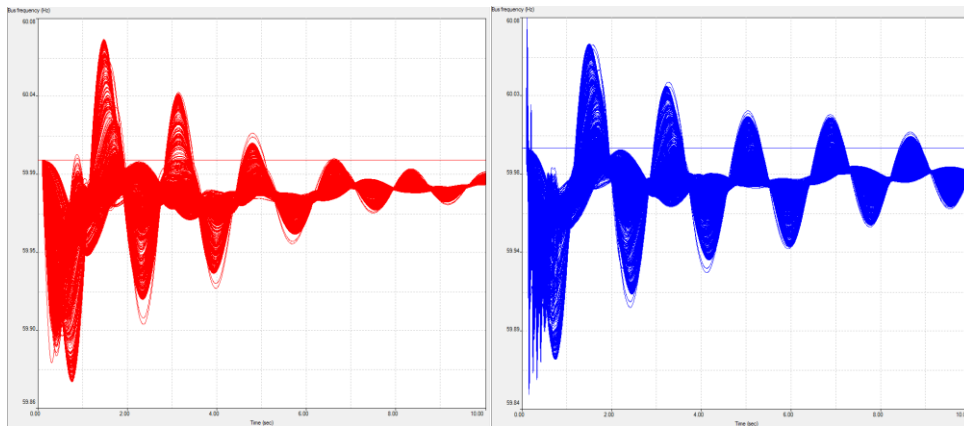

Figure 6.3.4: 45% and 60% Base Case Bus Frequency Response Plots

For comparison purposes, the two base case plots are overlaid in Figure 6.3.5. The differences reflect the increased wind generation in the models. Note the slower oscillation damping in the 60% case.

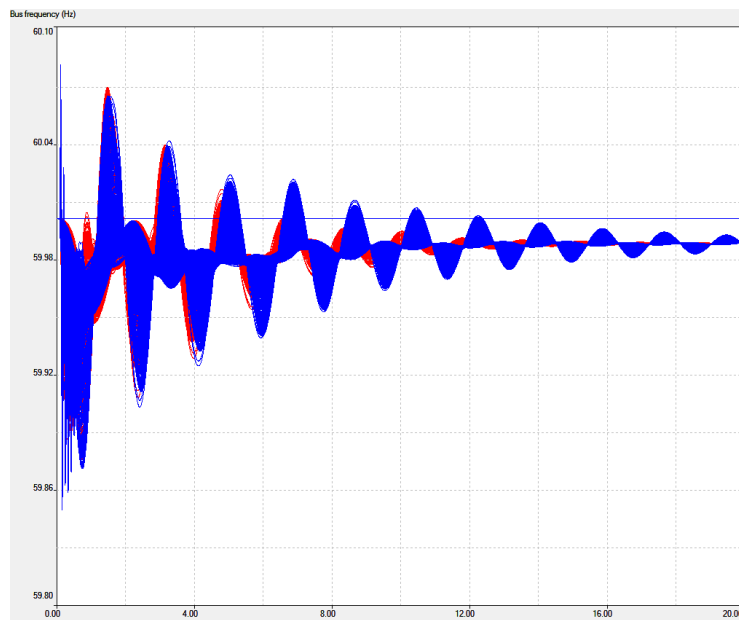

Figure 6.3.5: Overlaid Bus Frequency Responses

The Table 6.3.6 below shows the resulting frequency nadirs. These nadirs are well within the PRC Criteria for all cases. Figure 24 shows 45% base case frequency response with the overlaid PRC Criteria in red. Plots for the remaining three cases aren't needed due to close similarities.

Case	Frequency Nadir	Result
Base Case 60%	59.8749 Hz	Secure
Change Case 45%	59.8753 Hz	Secure
Base Case 60%	59.8489 Hz	Secure
Change Case 60%	59.849 Hz	Secure

Table 6.3.6: Results

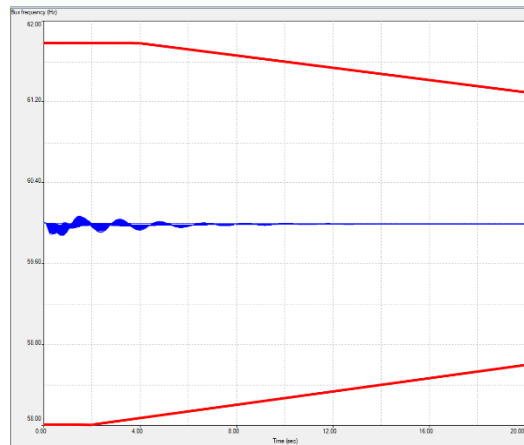

Figure 6.3.7: 45% Base Case with Overlaid Criteria

Comparing the change cases with the base cases, there was very little change in nadir and long-term response which suggests that the REPC_A models provided little assistance. Figure 6.3.8 is a typical wind machine’s active power output response for the base (black) and change (red) case. Notice there is little change in active power output. Additionally, the change case response is delayed and arrives after the frequency is arrested and the nadir occurs. This suggests there is no inertial response but some primary frequency control provided. This typical response was similar for all REPC_A equipped wind machines.

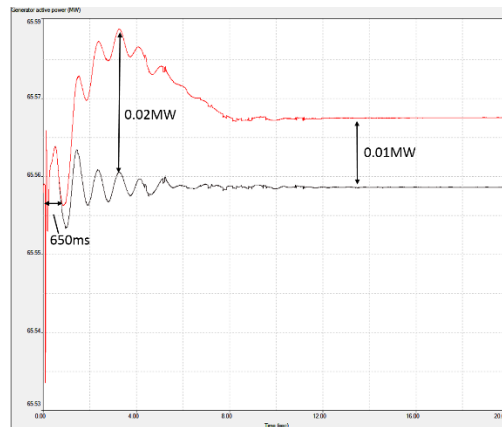

Figure 6.3.8: Typical Wind Machine Frequency Response

Since the frequency nadirs for all cases were well within criteria for the base cases, **there was no real need for frequency response from these wind machines in this study.**

Although the system was deemed secure in the simulations, Figures 6.3.4 and 6.3.5 reveal the presence of out-of-phase frequency oscillations. We know that *inter-area oscillations* occur when a power system is perturbed producing an oscillating power exchange between groups of generators in different areas of the power system. The figures suggest that inter-area oscillations exist when the Wolf Creek generator is removed from service. Figure 6.3.9 is a close-up of Figure 6.3.4, providing a better view of the oscillations. A **cursory evaluation** was conducted to which the remainder of this section is devoted.

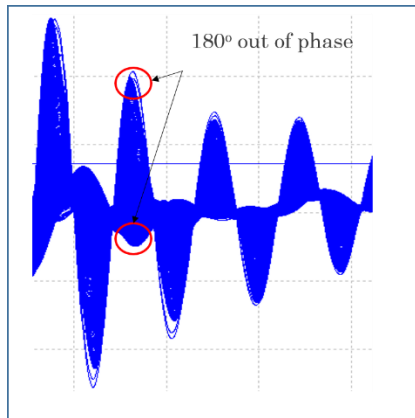

Figure 6.3.9: Inter-Area Oscillations

TSAT prony analysis was used to determine the approximate frequencies (modes) of oscillation and damping in the cases. Since the given base cases are similar, it was assumed they have the same natural frequencies of oscillation, so only one case (60% base case) was needed.

Numerous studies and analysis in the industry reveal that frequencies between 0.1 Hz to 1 Hz are *inter-area* modes of oscillation, meaning between two or maybe three areas of the power system. The prony analysis for the 60% base case revealed an approximate .556 Hz mode of oscillation with 4% damping ratio was excited when the Wolf Creek generator is removed.

DSATools SSAT (Small Signal Analysis Tool) was used for small signal analysis to compute the modes closest to the aforementioned frequency and damping. Twenty modes were identified with a wide range of stable and unstable eigenvalues. Table 8 identifies dominant modes that may be causing the interarea oscillations.

Mode	Eigenvalue	Frequency	Damping	Generators Participating
1	$-.1626 + j3.3808$	0.5381 Hz	4.80 %	69/2506
12	$-.2175 + j4.0651$	0.6470 Hz	5.34%	400/2506

Table 6.3.10: Dominant Modes

Analysis of modes was performed for mode 1 only. While mode 12 was a dominant mode affecting numerous generators, the loss of the Wolf Creek generator caused no SPP generators to participate in the interaction.

The scatter plot in Figure 6.3.11, show all generators in the model and how the Mode 1 shape appears under the perturbation. The x and y axes are the left eigenvector. The plot reveals that multiple units in SPS and a few in SUNC (red dots on right side of scatter plot) are swinging against units north of the SPP footprint (blue dots on the left side). Those units near the center do not participate in mode 1.

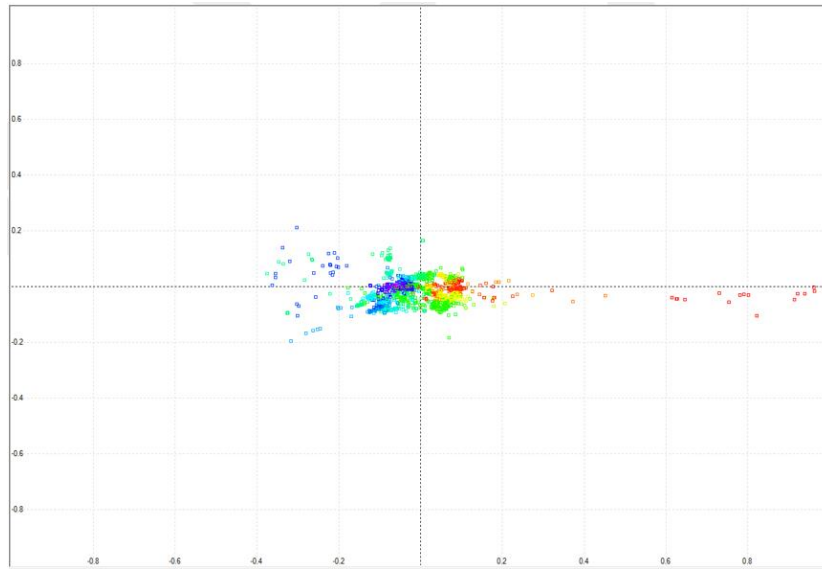

Figure 6.3.11: Mode 1 Scatter Plot

The mode 1 generators could be causing the frequency oscillations in Figure 6.3.4. Since small signal analysis is not included in the scope of work for this study, further analysis through an in-depth small signal study was not performed. However, the above cursory review reveals that more analysis is needed and is indeed recommended to determine the causes of these oscillations and the impact to the SPP system.

6.4 CONCLUSION

Results show the system is secure and no generators lose synchronism for the 45% and 60% wind penetration for the simulated event. Frequency response is in fully compliant with NERC established frequency response criteria. These results show that reliable integration of new and existing renewable resources can be accomplished at these penetration levels with regard to frequency response.

Inter-area frequency oscillations occur during the contingency event and further in-depth small signal analysis is required to determine exact causes and impacts.

SEASONAL VOLTAGE STABILITY ANALYSIS 2017 AND 2021

7.1 OVERVIEW OF VOLTAGE STABILITY

Nominal load is the active power the customer load will draw if it is operated at its nominal voltage and frequency. The actual load may be different than the nominal load. Voltage Stability is the ability of a power system to maintain voltage so that when the system nominal load is increased the MW transferred to that load will increase.⁶

When MW is transferred across a radial power system a curve can be created that relates the voltage at the receiving end of the system (V_R) to the MW transferred across the system. Figure 6.1.1 contains an example of this type of curve (called a power versus voltage curve or P-V curve). Note from this curve that as the MW transfer increases across the system, the voltage at the receiving bus (V_R) slowly decreases.

Eventually a point is reached (the “knee” of the P-V curve) where any further increase in MW transfer will lead to a rapid decrease in voltage. The knee of the P-V curve is the boundary between voltage stability and voltage instability. The voltage and MW transfer levels at the knee of the curve are called the “critical” values. For example, in Figure 6.1.1, the critical voltage is 70% of nominal and the critical MW transfer is 3000 MW.

Once the critical values are exceeded the system has entered a condition of voltage instability. The system voltage could collapse at any time. When voltage is unstable system operators have lost control of power transfer and voltage magnitude.⁷

⁶ Electric Power Research Institute, “EPRI Power system Dynamics Tutorial”, EPRI, Palo Alto, CA. 2009. 1016042, available at www.epri.com, Section 6.9.2, page 6-41.

⁷ Ibid, 6, Section 6.4.3, pages 6-6 through 6-7.

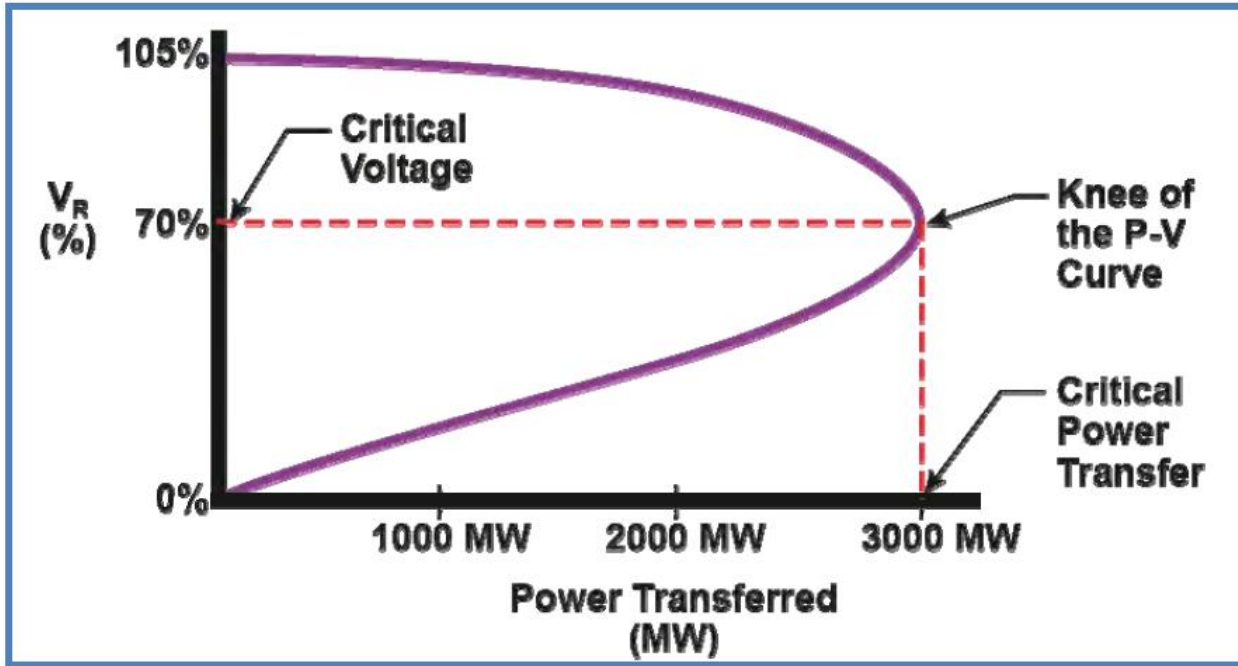

Figure 6.1.1: Sample P-V Curve

Assume the power system whose P-V curve is shown in Figure 6.1.2 is initially operating at an active power transfer of 2000 MW. From the curve the receiving bus voltage will be approximately 100% of nominal at this transfer level. Assume further that the system load (the nominal load) starts to grow. MW transfer grows with the increasing nominal system load. Eventually the MW transfer grows to 3000 MW.

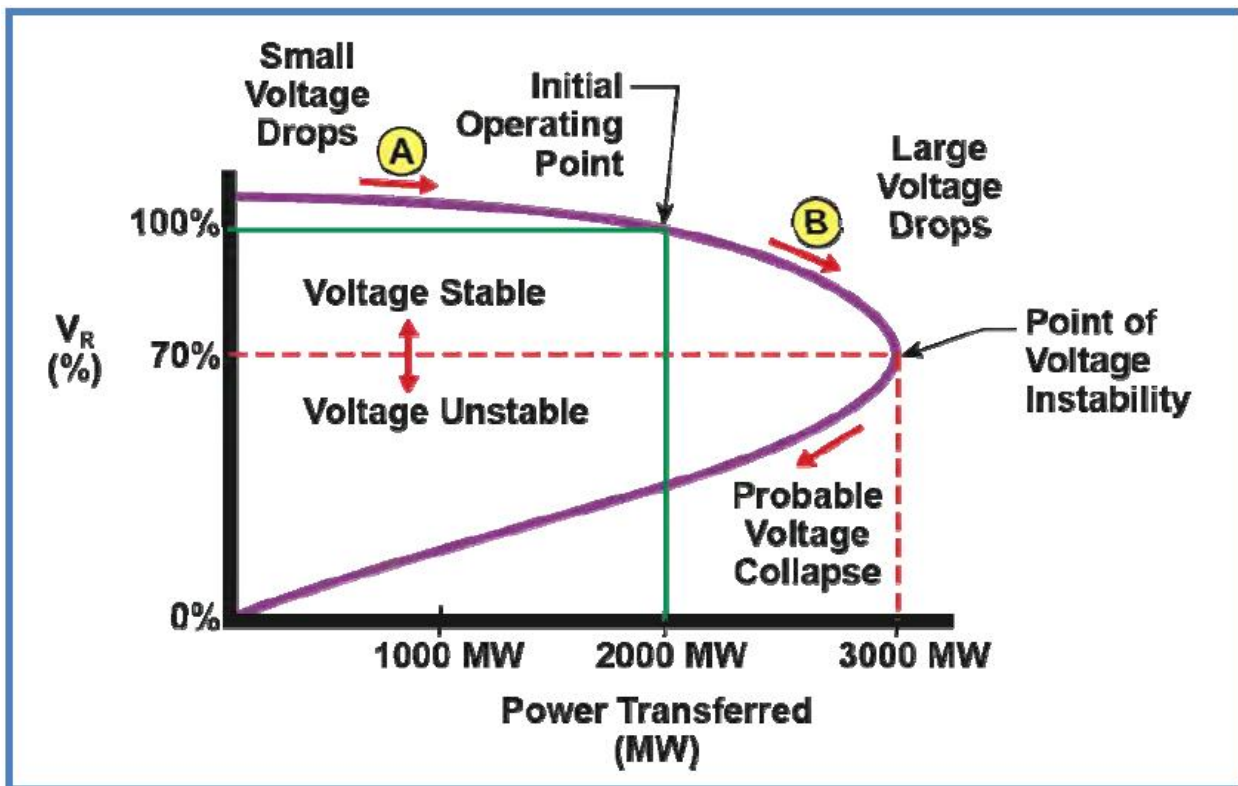

Figure 6.1.2: P-V Curve Illustration of Voltage Collapse

The system is now on the brink of voltage instability. If the nominal load were to grow any larger, the MW transferred to the load would actually begin to digress. Once the MW transfer exceeds the critical value the system is voltage unstable and the voltage collapse could occur at any time.⁸ See Appendix 1⁹ for a more detailed example of AC power transmission and the steady-state voltage stability limits.

Transmission outages reduce the current operating network point of voltage instability, refer to the post-disturbance curve in Figure 6.1.3.¹⁰

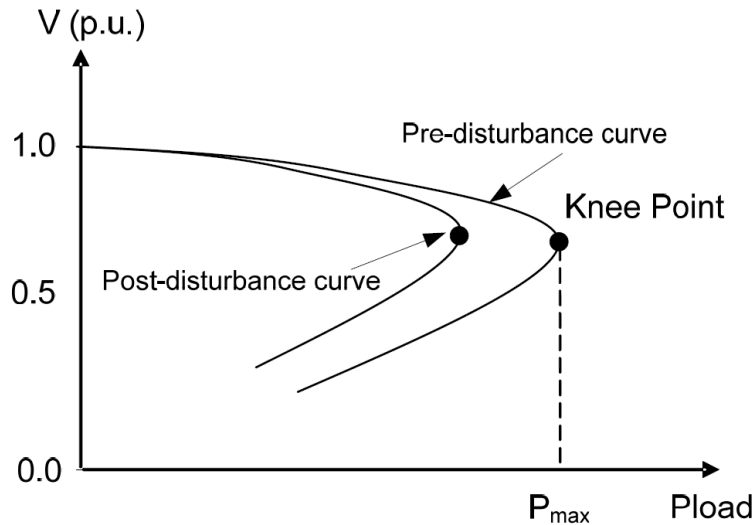

Figure 6.1.3: Maximum Power transfer reduction due to network outage (post-disturbance)⁴

The WIS voltage stability analysis (VSA) is performed by increasing generation power transfers on the Bulk Electric System (BES) to the point of voltage collapse. The renewable source generation is increased while the study thermal generation is reduced until source generation is at full capacity, sink generation is at zero MW, or voltage collapse occurs. Load remains constant during the power transfers. The study determines the voltage stability limit for the base case models and the top Four (4) most limiting single SPP 345 kV transmission and transformer outages.

The next section provides an overview of the voltage stability analysis assumptions, analysis, and results.

7.2 POWER TRANSFER AND REACTIVE RESERVES

This section provides a short description of how power transfer margins and reactive reserve requirements are defined in industry. The Western Electricity Coordinating Council (WECC)

⁸ Electric Power Research Institute, “EPRI Power system Dynamics Tutorial”, EPRI, Palo Alto, CA. 2009. 1016042, available at www.epri.com, Section 6.4.3, pages 6-6 through 6-7.

⁹ [Open Electrical: AC Power Transmission](#)

¹⁰ [Decision Tree Based Online Voltage Security Assessment Using PMU Measurements](#), Vijay Vitall, PSERC Seminar, January 27, 2009, Arizona State University, slide 26.

standard voltage stability margin is reference here to demonstrate the concept. WECC¹¹ maintains 105% transfer path voltage stability margin for Operational Transfer Capability for system normal conditions and for single contingencies. For multiple contingencies post transient voltage stability is required with a minimum of 102.5% Operational Transfer Capability. Figure 6.3.1 shows a plot of bus voltage versus interface flow or load real power (MW) for system normal conditions, single contingency, and multiple contingencies.¹²

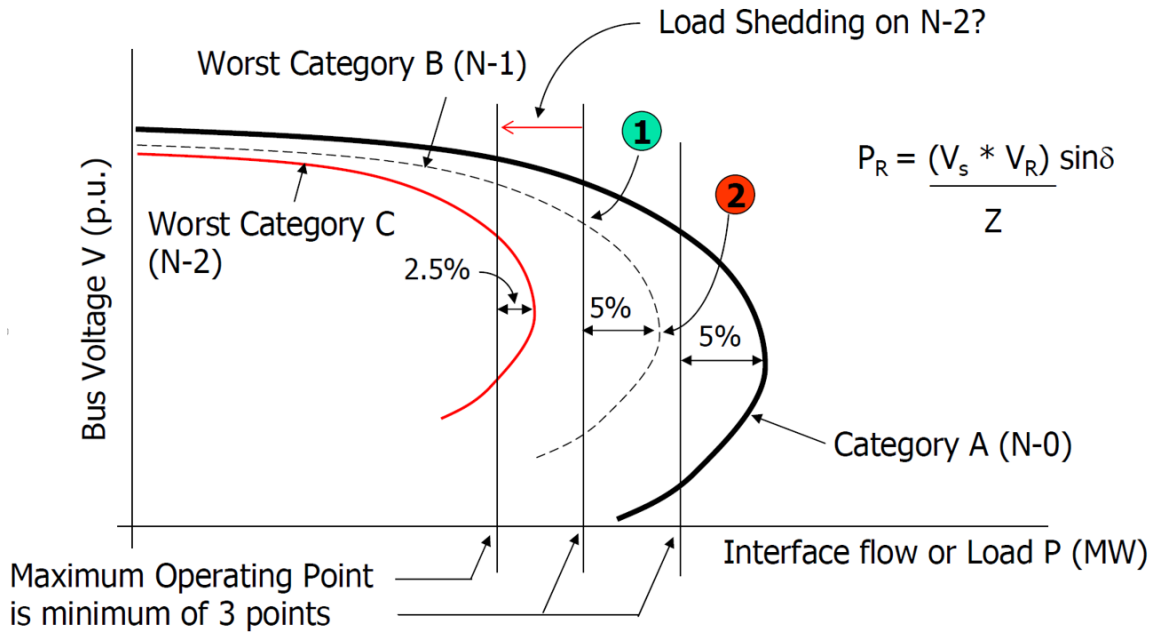

Figure 6.3.1: Interface flow or Load real power (MW) reserve margin.

The maximum operating point 1 for the worst case single contingency would require adequate reactive power (MVAR) reserves to support an additional 5% real power interface flow (MW) or load increase to voltage collapse, point 2.¹⁰ Figure 6.3.2 shows the reactive margin required at the maximum operating point in a voltage (V) versus reactive power (Q) plot.

¹¹ [Guide to WECC/NERC Planning Standards I.D: Voltage Support and Reactive Power, Reactive Reserve Working Group \(RRWG\)](#), March 30, 2006, Section 3, page 16.

¹² [Reactive \(VAR\) Reserve Margin](#), NARUC joint meeting Electric Reliability Staff Subcommittee & Electricity Staff Subcommittee, November 13, 2005, slides 14 through 18.

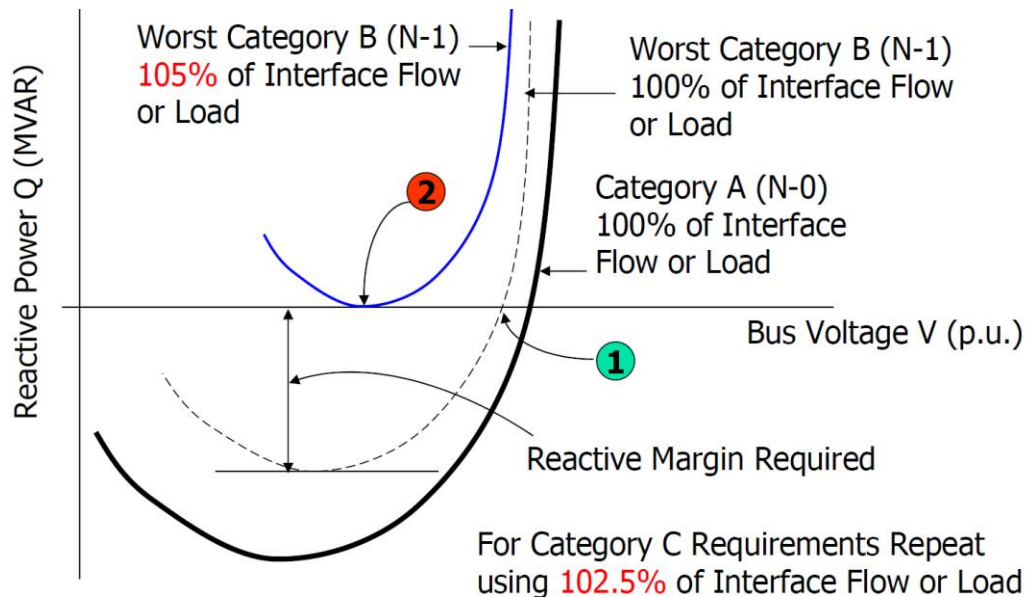

Figure 6.3.2: Reactive power (MVAR) reserve margin.¹⁰

¹³There are multiple considerations of uncertainties that drive the need for real power margins and reactive reserve

- Customer real and reactive power demand greater than forecasted
- Approximations in studies (Planning and Operations)
- Outages not routinely studied on the member system
- Outages not routinely studied on neighboring systems
- Unit trips following major disturbances
- Lower voltage line trips following major disturbances
- Variations on neighboring system dispatch
- Large and variable reactive exchanges with neighboring systems
- More restrictive reactive power constraints on neighboring system generators than planned
- Variations in load characteristics, especially in load power factors
- Risk of the next major event during a 30-minute adjustment period
- Not being able to readjust adequately to get back to a secure state
- Increases in major path flows following major contingencies due to various factors such as on-system undervoltage load shedding
- On-system reactive resources not responding
- Excitation limiters responding prematurely
- Possible Remedial Action Scheme failure
- Prior outages of system facilities
- More restrictive reactive power constraints on internal generators than planned.

¹³ [Reactive \(VAR\) Reserve Margin](#), NARUC joint meeting Electric Reliability Staff Subcommittee & Electricity Staff Subcommittee, November 13, 2005, slides 14 through 18.

7.3 OVERVIEW OF VOLTAGE STABILITY ANALYSIS

A voltage stability analysis was performed to determine stability for the 45% and 60% wind penetration Spring MDWG 2017 and 2021 base cases (with and without ops outages). Two sets of models, a base planning case and a planning model with historical operations outages included were analyzed. Single contingencies on all of the base models included SPP lines and transformers above 100kV, interfaces, flowgates and circuits, per latest NERC event file. Monitored elements will include NERC event monitored elements and SPP thermal overloads due to transfers. Voltage instability prior to reaching thermal limits was cause for redispatch to avoid voltage collapse. When local voltage stability or thermal limitations were reached, a generation re-dispatch was performed utilizing a block dispatch in the following order: 1st thermal units (except Nuclear)(Gas to pmin then offline and Coal to pmin then offline), 2nd DVERS (dispatchable variable energy resources)(Hydro/Wind/Solar), 3rd NDVERS (Non-dispatchable Variable Energy Resources)(Hydro/Wind), to remedy violations. A 5% voltage stability margin was also used for wind transfers, flowgate limits, and load increase limits. The base models included SPP firm wind commitment to external areas.

The system study started from 45% wind penetration level. Four base cases starting from 45% penetration are 2017 with outages case, 2017 without outages case, 2021 with outages case, and 2021 without outages case. Despite minor overload, the 2021 without outages case can be dispatched to 60% wind penetration level, so another case, 2021 60% without outages case was studied, which can also be dispatched to maximum transfer if ignore few minor overloads. The dispatch results and limiting contingencies for all five scenarios are summarized in Table 7.2.1.

<i>Scenario</i>	<i>Start (MW)</i>	<i>Limit (MW)</i>	<i>If To Max?</i>	<i>Limiting Contingency</i>
2017 45% With Outages	10676.6	10686.6	NO	TATONGA7 - MATHWSN7 345kV
2017 45% No Outages	10674.0	11094.0	NO	TATONGA7 - MATHWSN7 345kV
2021 45% With Outages	11061.1	11941.1	NO	CIMARON - FSHRTAP 345kV
2021 45% No Outages	11048.7	14747.8	YES	N/A
2021 60% No Outages	14747.8	15550.0	YES	N/A

Table 7.2.1: Transfer Limit Summary

7.4 SIMULATION CASE SETUP

Some common settings used in the simulation analysis for all cases are detailed in this subsection. In each simulation case, powerflow file is specific to each scenario. Control settings, contingency list, stability criteria, SPS file, and governor response file are common. The voltage limits criteria are used for monitoring voltage limits only and are not considered as limiting constrain.

Control settings have set in the analysis for all study cases. In pre-contingency stage:

- Generation – remote voltage control enabled
- Transformers – taps enabled
- Phase shifting transformers – enabled
- Discrete switched Shunts – enabled
- SVC and continuous switched shunt – enabled
- Line Shunts – fixed
- HVDC – fixed schedule

SPS action - disabled

In post-contingency stage:

Generation – AVR local voltage control

Transformers – taps locked

Phase shifting transformers – locked

Discrete switched Shunts – locked

SVC and continuous switched shunt – enabled

Line Shunts – fixed

HVDC – fixed schedule

SPS action - enabled

Stability criteria are set to check branch flows and monitor voltage limits in SPP footprint. Only voltage level above 100kV components are checked or monitored. The branch flows check settings are:

Pre-contingency – Line Rating: 1; Transformer Rating: 1; Flow Check Threshold: 100%

Post-contingency – Line Rating: 2; Transformer Rating: 2; Flow Check Threshold: 100%

The voltage limits monitoring settings are:

Pre-contingency – Low Limit: 0.95pu; High Limit: 1.05pu.

Post-contingency – Low Limit: 0.90pu; High Limit: 1.05pu.

Contingency list is generated by T-1 for all branches above 100kV in SPP footprint.

7.5 BASE CASE CLEANUP

A few data errors have been identified prior the analysis. During the analysis, some minor data changes are made to improve better powerflow convergence and prevent solution hunting.

Data errors are:

Reactance on line CANDOJCT-CP869.0 - CANDOTP2-CP869.0 was 192142pu and changed to the correct value: 0.192142pu

Line ratings on FLETCHR2 - MARLOWJ2 138kV is corrected to 103MVA/160MVA

Line ratings on BC-EARTH - PLANT_X 115kV is corrected to 120MVA/154MVA

Power output from wind farms SLICKHILLS and BLUCAN exceed generators' maximum limit and also exceed the feeder thermal limit. The changes were curtailing power output of those wind farms to be within the limit.

Equivalence low voltage radial lines to improve voltage stability:

Voltage stability issue occurs in SPS-LEA area, i.e., low voltage (69kV) buses near HOBBS, Maddox, Buckeye, San Andres area. Instability occurs at contingency: O.K.U. – L.E.S. 345kV and TATONGA – MATHWSN 345kV;

To improve better powerflow convergence, the following minor powerflow changes are made:

Tertiary out at three winding transformers:

MCNOWND7 345.

PALDR2W7 345.

BUFLOCRK6 230.

Minor impedance change at three winding transformers:

- N-DODGE3 115. - Primary Reactance; -0.696591 pu
- SUNDOWN6 230. - Tertiary Reactance; 0.062835 pu
- MCNOWND7 345. - Secondary Reactance; 0.0530078 pu
- CRSRDW11 34.5 - Secondary Reactance; 0.00998 pu
- CRSRDW21 34.5 - Secondary Reactance; 0.0107786 pu
- MAMTHPW7 345. - Secondary Reactance; 0.0107786 pu

Phase shift correction at adjustable transformers:

- PRWNDCL1 34.5
- SHP234 1 34.5

7.6 2017 45% WITH OUTAGES CASE

2017 45% with outages case can be dispatched (ignoring any overload below 107%) from base 10676.6MW to 10686.6MW (10MW increased). At 10696.6MW, the transfer hits voltage collapse at the contingency TATONGA7 - MATHWSN7 345kV. Overloads were present in the base case. Overloads, sorted by most severe contingencies at the top, for both pre and post contingency results are detailed in Table 7.6.1 and Table 7.6.2. The most significant overload was 164%, caused by the Tatonga – Mathewson contingency. The base case was re-dispatched to mitigate severe overloads and discussed the next section.

OVL #	Overloaded Branch	Area Name	MVA Rating	OVL %	Contingency
1	WASHITA4 138. - SLICKHILLS4 138	WFEC	324.00	103.3	Pre-contg.
2	WOODWRD4 138. - WINDFRM4 138	OKGE	153.00	100.9	

Table 7.6.1: Pre-Contingency Overloads

OVL #	Overloaded Branch	Area Name	MVA Rating	OVL %	Contingency
1	WOODWRD4 138. - WINDFRM4 138	OKGE	153.00	164.3	TATONGA7 345. - MATHWSN7 345.
2	WINDFRM4 138. - MOORLND4 138	OKGE-WFEC	287.00	110.5	
3	WEBBTAP4 138. - OSAGE 4 138	AEPW-OKGE	191.00	121.0	CLEVLND7 345. - SOONER 7 345.
4	SUNDOWN 6230. - AMOCO_SS 6230	SPS	318.69	119.5	TOLK_WEST 6230. - YOAKUM 6230.
5	PLANT_X 6230. - SUNDOWN 6230	SPS	318.69	115	
6	WOODWRD4 138. - WINDFRM4 138	OKGE	153.00	116.3	WWRDEHV7 345. - TATONGA7 345.
7				114.6	ELKCITY6 230. - SWEETWT6 230.
8	OCHOA 3115. - WHITTEN 3115	SPS	141.22	111.5	POTASH_JCT 6230. - RDRUNNER 6230.
9	SUNDOWN 6230. - AMOCO_SS 6230	SPS	318.69	111.1	CROSSROADS 7345. - EDDY_CNTY 7345.
10	PLANT_X 6230. - SUNDOWN 6230	SPS	318.69	109.2	
11	WOODWRD4 138. - WINDFRM4 138	OKGE	153.00	110.3	O.K.U.-7 345. - L.E.S.-7 345.

12	HUTCH_S 3115. - MARTIN 3115	SPS	119.51	109.3	HIGHLAND_TP3115. - PANTEX_S 3115.
13		SPS		108.9	MARTIN 3115. - PANTEX_N 3115.
14	WOLFFORTH 3115. - TERRY_CNTY 3115	SPS	119.51	108.7	SUNDOWN 6230. - AMOCO_SS 6230.
15	LG-CLAUENE 3115. - TERRY_CNTY 3115	SPS	79.67	105.8	
16	TOLK_WEST 6230. - YOAKUM 6230	SPS	318.69	103.8	
17	HUTCH_S 3115. - MARTIN 3115	SPS	119.51	108.3	
18	WOODWRD4 138. - WINDFRM4 138	OKGE	153.00	108.1	WINDFRM4 138. - FPLWIND4 138.
19	LE-WEST_SUB3115. - LE-NRTH_INT3115	SPS	131.46	104.6	CUNNINGHAM 3115. - BUCKEYE_TP 3115.
20	TUPELO 4 138. - TUPLOTP4 138	SWPA-WFEC	143.00	103.2	SUNNYS7 345. - HUGO 7 345.
21	WOODWRD4 138. - WINDFRM4 138	OKGE	153.00	102.7	FTSUPPLY4 138. - SLEEPING 138.
22				102.6	IODINE-4 138. - WWRDEHV4 138.
23	BUTLER 4 138. - ALTOONA4 138	WERE	96.00	102.2	CANEYRV7 345. - NEOSHO 7 345.
24	PLANT_X 3115. - LAMB_CNTY 3115	SPS	79.67	101.7	TOLK_WEST 6230. - LAMB_CNTY 6230.
25	LE-WEST_SUB3115. - LE-NRTH_INT3115	SPS	131.46	101.4	BUCKEYE_TP 3115. - LE-TXACO_TP3115.
26	WOODWRD4 138. - WINDFRM4 138	OKGE	153.00	100.7	DEWEY 4 138. - IODINE-4 138.
27	PLANT_X 6230. - SUNDOWN 6230	SPS	318.69	100.7	TUCO_INT 6230. - JONES 6230.
28				100.3	LUBBCK_STH 6230. - WOLFFORTH 6230.

Table 7.6.2: Post-Contingency Overloads

The most severe overloads caused by contingencies are numbered (OVL #) in Table 7.6.2. This section suggests re-dispatch patterns to mitigate severe overloads.

For the scope of this study, the procedure to re-dispatch in the following order: 1st thermal units (except Nuclear), 2nd DVERS (dispatchable variable energy resources), 3rd NDVERS (Non-dispatchable Variable Energy Resources) to remedy the violation. However, most overloads were very local to their area. In some cases NDVERS were dispatched, however their wind MW change was picked up by other wind units in SPP. Typically generators were often chosen due to their proximity to overloaded branches.

After mitigating severe overloads, further re-balancing dispatch for the purposes of maintaining wind penetration was performed. Some additional units were also turned on for voltage stability issues after re-balancing.

7.6.1 CONSTRAINT RE-DISPATCH ACTIONS

7.6.1.1 WOODWRD4 138kV. - WINDFRM4 138kV ftlo TATONGA7 345kV. - MATHWSN7 345kV.

This overload was relieved to under 110% by performing the following re-dispatch shown below:

Type	Generator	Old	New	Switch On
Thermal	MORLND4 18.0	0	300	Yes
NDVER	CENT 21 34.5	62.51	10	N/A
NDVER	OUSPRT 1 34.5	79.12	10	N/A

These actions relieved post-contingency overloads for OVL # 1, 2, 6, 7, 11 below 110% overload

7.6.1.2 WEBBTAP4 138kV. - OSAGE 4 138kV ftlo CLEVLND7 345kV. - SOONER 7 345kV.

This overload was relieved to under 110% by performing the following re-dispatch shown below:

Type	Generator	Old	New	Switch On
Thermal	SOONER1G 22.0	477.36	75	N/A
NDVER	KEENAN 1 34.5	118.36	100	N/A
NDVER	FPLWND11 34.5	80.27	50	N/A

These actions relieved post-contingency overloads for OVL # 3 below 110% overload

7.6.1.3 SUNDOWN 230kV. - AMOCO SS 230kV ftlo TOLK WEST 230kV. - YOAKUM 230kV.

This overload was relieved to under 110% by performing the following re-dispatch shown below:

Type	Generator	Old	New	Switch On
Thermal	TOLK_2 124.0	535	350	N/A
Thermal	TOLK_1 124.0	384.5	350	N/A
Thermal	MUSTANG_3 122.0	0	100	Yes
Thermal	MUSTANG_1 113.8	0	100	Yes

These actions relieved post-contingency overloads for OVL # 4, 5 below 110% overload

7.6.1.4 OCHOA 115kV. - WHITTEN 115kV ftlo POTASH JCT 6 230kV. - RDRUNNER 6 230kV.

This contingency creates several radial lines with loads at the end. Ochoa – Whitten is one of those radial lines that gets overloaded. Due to this topology, it is not possible to relieve the overload by dispatch (see Figure 7.6.3)

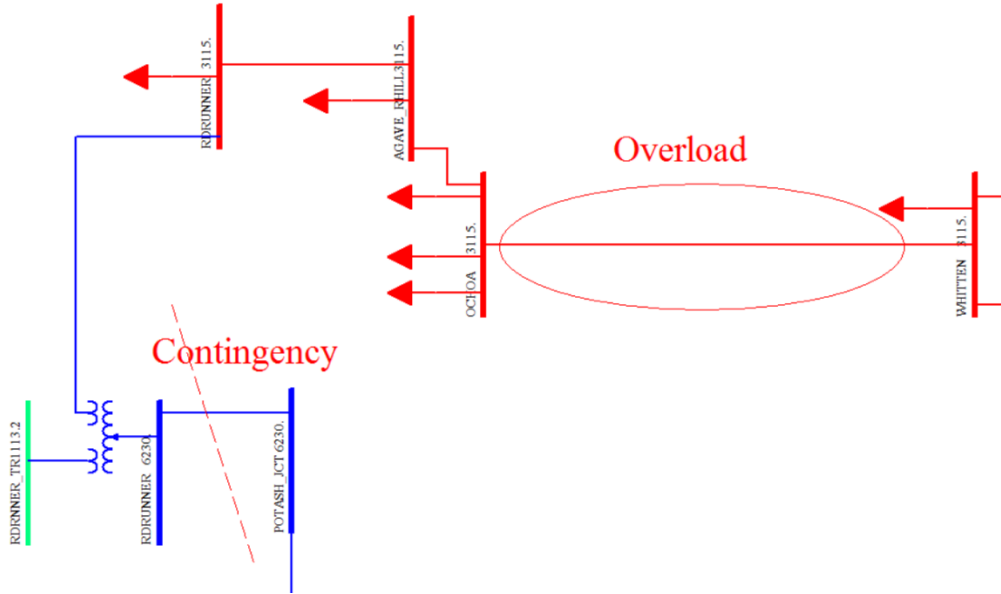

Figure 7.6.3: Radial Loads after Contingency

7.6.1.5 HUTCH S 115kV. - MARTIN 115kV ftlo HIGHLAND TP 115kV. - PANTEX S 115kV.

This overload was relieved to under 110% by performing the following re-dispatch shown below:

Type	Generator	Old	New	Switch On
NDVER	MAJSTC-WTG110.69	61.16	50	N/A

This action relieved post-contingency overload for OVL # 8 below 110% overload

7.6.2 DISPATCH BALANCING FOR MAINTAINING WIND PENETRATION

Once severe overloads (over 110%) has been relieved, total thermal generation has decreased by 122MW and total wind has decreased by 355MW. The loss of thermal MW and wind MW where balanced separately.

The 122MW thermal deficit was evenly picked up by thermal generators used the in “sink” of the transfer definition of the system stability study done in the previous chapter.

The 355MW wind deficit was evenly picked up by the wind units in the “source” of the transfer definition used in both the system stability and load pocket study.

Dispatch balancing was performed in VSAT by creating a special case that would apply a thermal generation re-dispatch and a separate wind generation re-dispatch. Separate thermal and wind governor files where used to pick-up the missing generation, instead of using the swing bus.

7.6.3 DISPATCH FOR VOLTAGE STABILITY ISSUES AFTER BALANCING

After balancing to maintain wind penetration, contingencies “TATONGA7 345kV. - MATHWSN7 345kV.” and “O.K.U.-7 345kV. to L.E.S.-7 345kV.” were found to be voltage unstable at the base.

To obtain an idea of where the system is collapsing for those contingencies, modal analysis was performed. Since those contingencies cause the powerflow to diverge, the base case pre-contingency was taken, then the impedance of the “TATONGA7 345kV. - MATHWSN7 345kV.” line was increased simulate a partial outages while still enabling the powerflow to solve. Modal analysis was performed on this powerflow. The participation factors are plotted in Figure 7.6.4 which indicates a collapse in the south Oklahoma region.

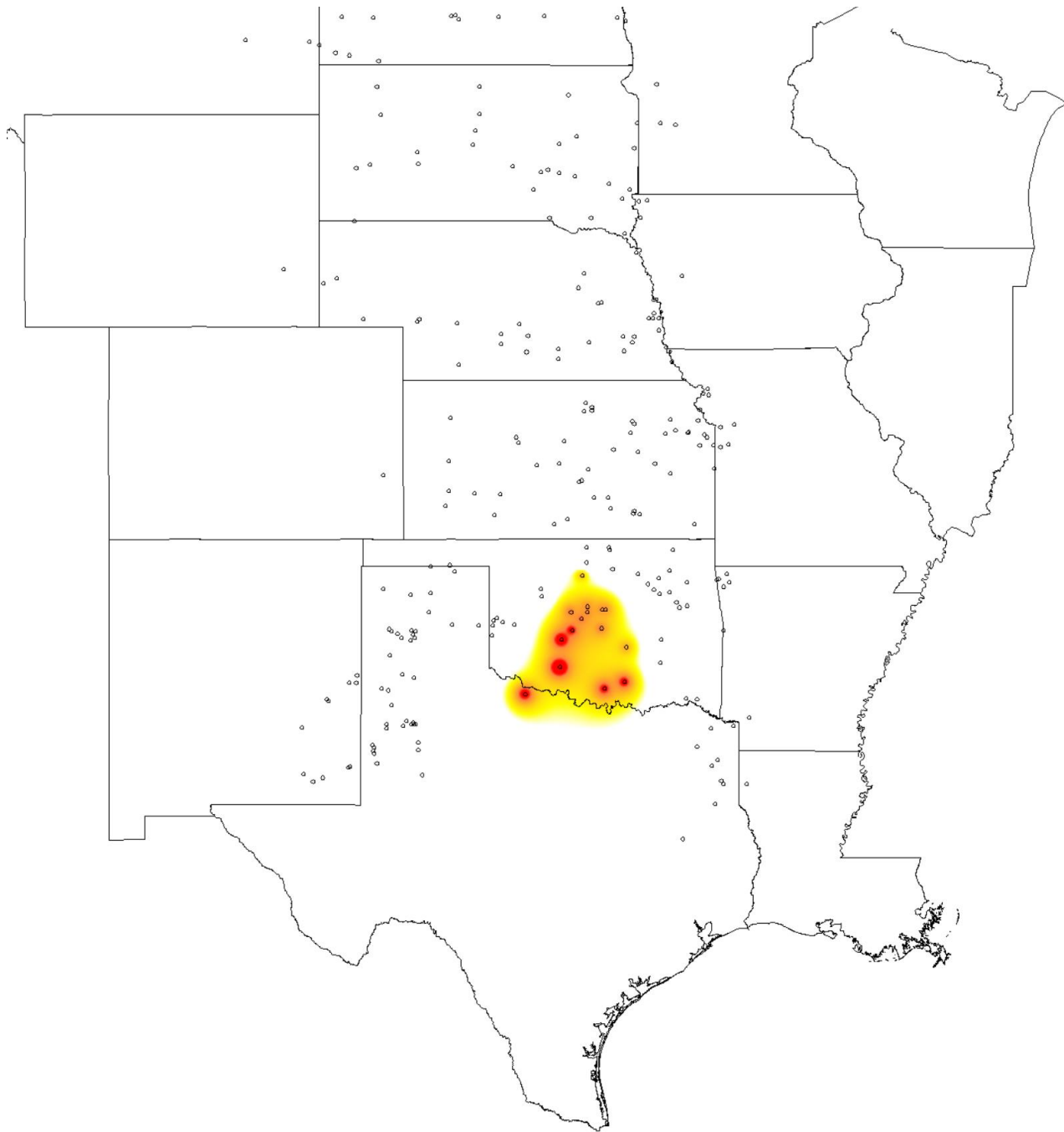

Figure 7.6.4: Modal Analysis Participation Factor Contour

To resolve voltage collapse for these two contingencies, the following re-dispatch shown below was used.

Type	Generator	Old	New	Switch On
Thermal	REBUD4S 18.0	0	36	Yes
Thermal	MCLN 2G 18.0	0	42	Yes

These thermal units were selected due to their location in the Oklahoma region. These units did not have Pmin greater than zero, so they were set to 25% of Pmax. There are a total of eight REDBUD units, this re-dispatch is only activating one unit, and the other seven remain out-of-service. Similarly there are three MCLN units, this re-dispatch is only activating one unit, and the other two units remain out-of-service.

These units were turned on for their MVAR capacity to help with voltage support. The REDBUD unit has an output of 70MVAR and the MCLN unit has 58MVAR.

Then re-balanced, using the same procedure documented in the previous subsection, was used to maintain wind penetration. VSAT was then used to solve the base case for all contingencies. The base case was found to be voltage stable for all contingencies.

7.6.4 Woodward Phase Shifter Effect

This Woodward phase shifter was not in-service in the original 2017 case. But to test its effectiveness, a separate simulation study assumes it is in-service and operates at 15 degrees. Simulation shows that this phase shifter relieves WOODWRD4 - WINDRM4 138kV ftlo TATONGA7 - MATHWSN7 345kV overload successfully and increases security limit 90MW. The limiting contingency is TATONGA7 - WWRDEHV7 345kV.

The base power flow used for this study starts with the same power flow as in **7.6.1 CONSTRAINT RE-DISPATCH ACTIONS** section in this chapter. However, additional changes were made are discussed below.

1. The Woodward phase shifter operating at 15 degrees was added between buses WOODWRD4 138kV and WWRDEHV4 138kV.
2. **WOODWRD4 138kV. - WINDFRM4 138kV ftlo TATONGA7 345kV. - MATHWSN7 345kV.**
 It was found that this phase shifter completely relieves this overload in base case. Therefore the basecase re-dispatches made for this overload were not needed and were not applied. Therefore the MORLND4 18.0, CENT 21 34.5, and OUSPRT 1 34.5 units were not re-dispatched.
3. **ELKCITY6 230kV. - ELKCTY-4 138kV. Overload ftlo. O.K.U.-7 345kV. - L.E.S.-7 345kV.**
 The addition of the phase shifter caused this overload to go above 110%. This was relieved with the re-dispatch shown below. Reduction of the DVER was insufficient to alleviate the overload, so the NDVER was also scaled down. (Note: later it was stated by AEP that the rating should be 331MVA instead of 316MVA, which may have prevented the need for this action).

<i>Type</i>	<i>Generator</i>	<i>Old</i>	<i>New</i>	<i>Switch On</i>
DVER	ROARK1 34.5	76.37	60	N/A
NDVER	DEMPSEY1 34.5	103.29	80	N/A

4. Re-balancing of thermal and wind units to maintain wind penetration was then applied after the above changes were made.

7.6.5 Voltage Violations

Please refer to section 8.6 VOLTAGE VIOLATIONS.

7.7 2017 45% WITHOUT OUTAGES CASE

2017 45% without outages case can be dispatched (ignoring any overload below 107%) from base 10674.0MW to 11094.0MW (420MW increased). At 11104MW, the transfer hits voltage collapse at the contingency TATONGA7 - MATHWSN7 345kV. Modal analysis and contour maps show voltage collapse at central Oklahoma. The voltage contour map is shown in Figure 7.7.1. There are three significant overload instances in the base case. Line WOODWRD4 - WINDRM4 138kV was heavily overloaded (over 150%) at the base. The overload instances in base case are summarized in Table 7.7.1.

Rescheduling schemes were performed to mitigate those overload instances. In summary, the net renewable MW reschedule is curtailing 133MW; the net thermal MW reschedule is increasing 133MW. Both net renewable and net thermal MW changes due to the reschedule schemes have been balanced out by other renewable and thermal units in SPP footprint, so the net MW changes are negligible. After the MW balancing process, reschedule schemes proved to be no impact on the initial wind penetration level.

OVL #	Overloaded Branch	Area Name	MVA Rating	OVL %	Contingency
1	WOODWRD4 138. - WINDFRM4 138	OKGE	153.00	156.9	TATONGA7 345. - MATHWSN7 345.
2	WINDFRM4 138. - MOORLND4 138	OKGE-WFEC	287.00	107.7	
3	SUNDOWN 6230. - AMOCO_SS 6230	SPS	318.69	117.8	TOLK_WEST 6230. - YOAKUM 6230.
4	PLANT_X 6230. - SUNDOWN 6230	SPS	318.69	113.5	
5	WOODWRD4 138. - WINDFRM4 138	OKGE	153.00	113.6	ELKCITY6 230. - SWEETWT6 230.
6				112.3	WWRDEHV7 345. - TATONGA7 345.
7	SUNDOWN 6230. - AMOCO_SS 6230	SPS	318.69	110.3	CROSSROADS 7345. - EDDY_CNTY 7345.
8	PLANT_X 6230. - SUNDOWN 6230	SPS	318.69	108.6	
9	WOODWRD4 138. - WINDFRM4 138	OKGE	153.00	109.8	O.K.U.-7 345. - L.E.S.-7 345.
10	HUTCH_S 3115. - MARTIN 3115	SPS	119.51	108.4	HIGHLAND_TP3115. - PANTEX_S 3115.
11				108.0	MARTIN 3115. - PANTEX_N 3115.
12				107.4	PANTEX_N 3115. - PANTEX_S 3115.

13	LG-CLAUENE 3115. - TERRY_CNTY 3115	SPS	79.67	107.3	SUNDOWN 6230. - AMOCO_SS 6230.
14	WOLFFORTH 3115. - TERRY_CNTY 3115	SPS	119.51	106.5	
15	TOLK_WEST 6230. - YOAKUM 6230	SPS	318.69	102.3	
16	WOODWRD4 138. - WINDFRM4 138	OKGE	153.00	106.2	WINDFRM4 138. - FPLWIND4 138.
17	LE-WEST_SUB3115. - LE-NRTH_INT3115	SPS	131.46	102.1	CUNNINHAM 3115. - BUCKEYE_TP 3115.
18	WOODWRD4 138. - WINDFRM4 138	OKGE	153.00	101.1	FTSUPPLY4 138. - SLEEPING 138.
19	PLANT_X 3115. - LAMB_CNTY 3115	SPS	79.67	101.0	TOLK_WEST 6230. - LAMB_CNTY 6230.
20	PLANT_X 6230. - SUNDOWN 6230	SPS	318.69	100.7	LUBBCK_STH 6230. - WOLFFORTH 6230.
21	WOODWRD4 138. - WINDFRM4 138	OKGE	153.00	100.4	IODINE-4 138. - WWRDEHV4 138.

Table 7.7.1 Overloads in base case

7.7.1 CONSTRAINT RE-DISPATCH ACTIONS

7.7.1.1 WOODWRD4 - WINDRM4 138kV ftlo TATONGA7 - MATHWSN7 345kV

The reschedule scheme is in the following table:

<i>Type</i>	<i>Generator</i>	<i>Old</i>	<i>New</i>	<i>Switch On</i>
Thermal	MORLND4 18.0	0	150	Yes
NDVER	CENT 21 34.5	62.51	10	N/A
NDVER	OUSPRT 1 34.5	79.12	10	N/A

The reschedule scheme also relieves overload OVL # 2, 5, 6, 9, and 16

7.7.1.2 SUNDOWN - AMOCO SS 230kV ftlo TOLK WEST - YOAKUM 230kV

The reschedule scheme is in the following table.

<i>Type</i>	<i>Generator</i>	<i>Old</i>	<i>New</i>	<i>Switch On</i>
Thermal	TOLK_1 124.0	381.69	350	N/A
Thermal	TOLK_2 124.0	535.00	350	N/A

The reschedule scheme also relieves overload OVL # 4, 7, 8, and 15

7.7.1.3 HUTCH S - MARTIN 115kV ftlo HIGHLAND TP3 - PANTEX S 115kV

The reschedule scheme in the following table:

<i>Type</i>	<i>Generator</i>	<i>Old</i>	<i>New</i>	<i>Switch On</i>
NDVER	MAJSTC-WTG110.69	61.16	50.00	N/A

The reschedule scheme also relieves overload OVL # 11, and 12

7.7.1.4 LG-CLAUENE - TERRY CNTY 115kV ftlo SUNDOWN - AMOCO SS 230kV

The reschedule scheme in the following table:

<i>Type</i>	<i>Generator</i>	<i>Old</i>	<i>New</i>	<i>Switch On</i>
Thermal	MUSTANG_1 113.8	0	100	Yes
Thermal	MUSTANG_3 122.0	0	100	Yes

The reschedule scheme also relieves overload OVL # 14

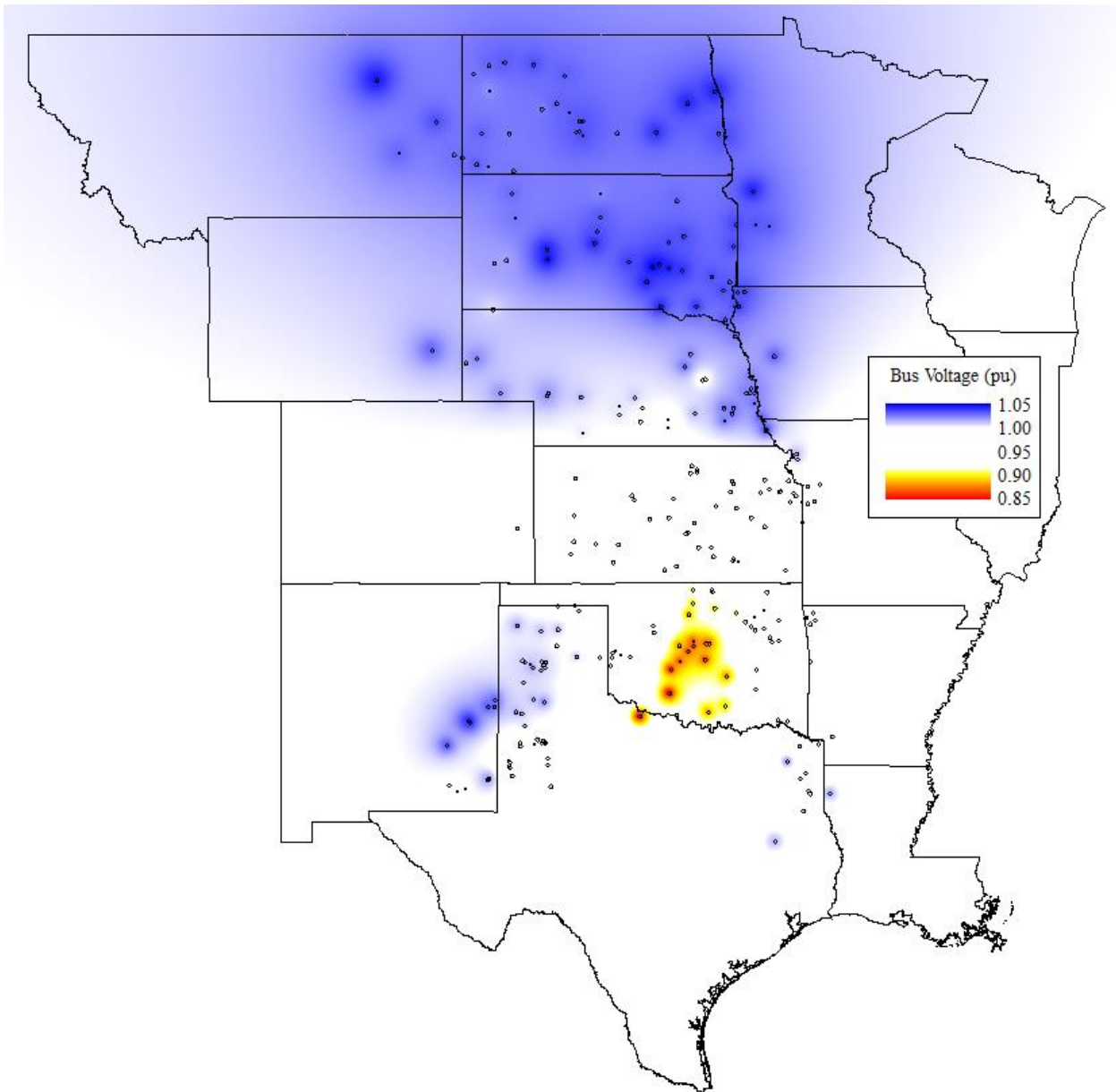

Figure 7.7.1 Voltage contour map at the last secure point prior voltage collapse

7.7.2 V-P Curve and Q-V Curves

Critical 345kV above buses were identified using modal analysis result. V-P curve has been plotted for those critical buses in Figure 7.7.2.

19-OCT-16
 Bus Voltage (pu) Contingency: TATONGA7 345. - MATHWSN7 345.

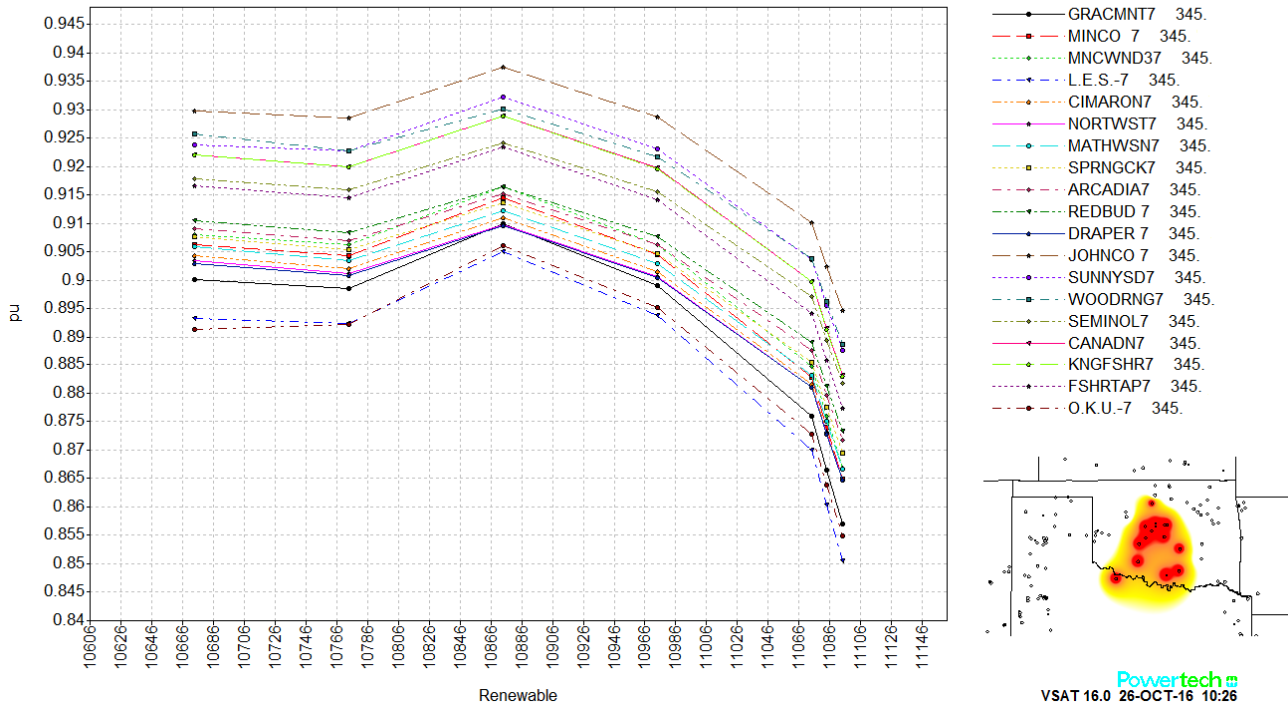

Figure 7.7.2 V-P curves of 345kV buses near stability limit location

The Q-V curve at the base transfer point (10674MW) is shown in Figure 7.7.3. The Q-V curve at 95% security margin ($10674+420*95%=11073\text{MW}$) is shown in Figure 7.7.4.

19-OCT-16
Transfer Renewable to The
VQ Curve

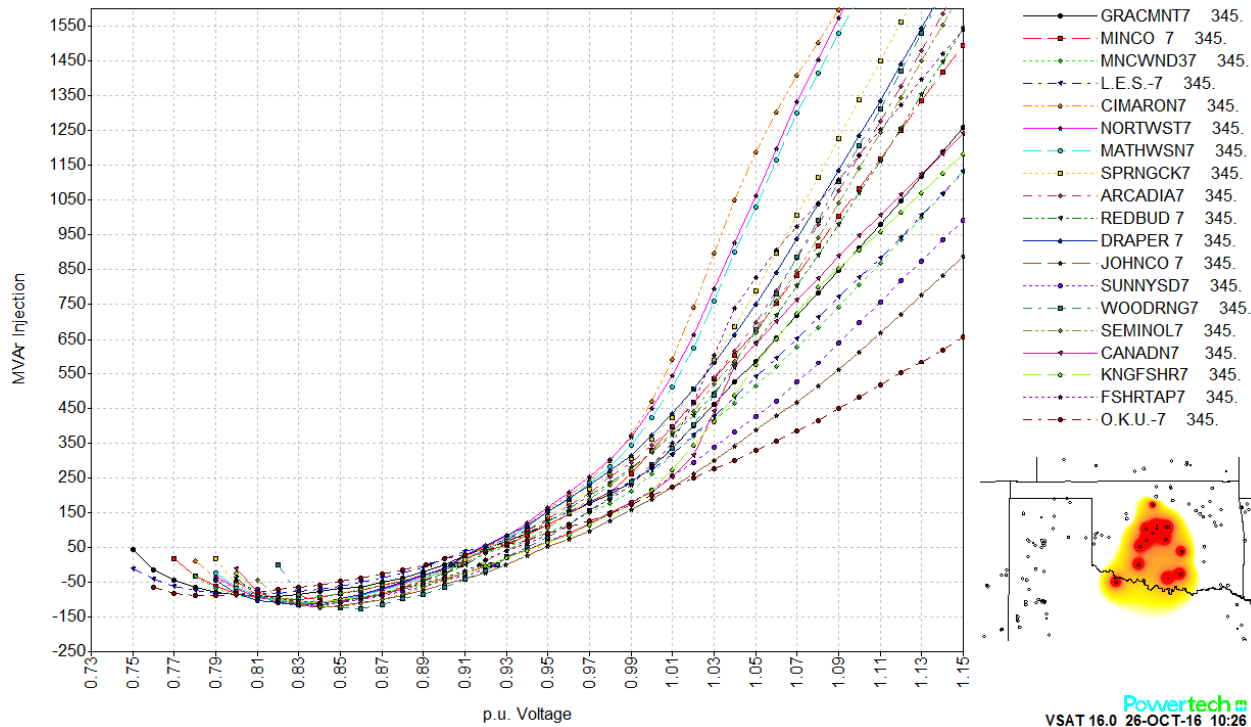

Figure 7.7.3 Q-V curve at the base transfer

19-OCT-16
Transfer Renewable to The
VQ Curve

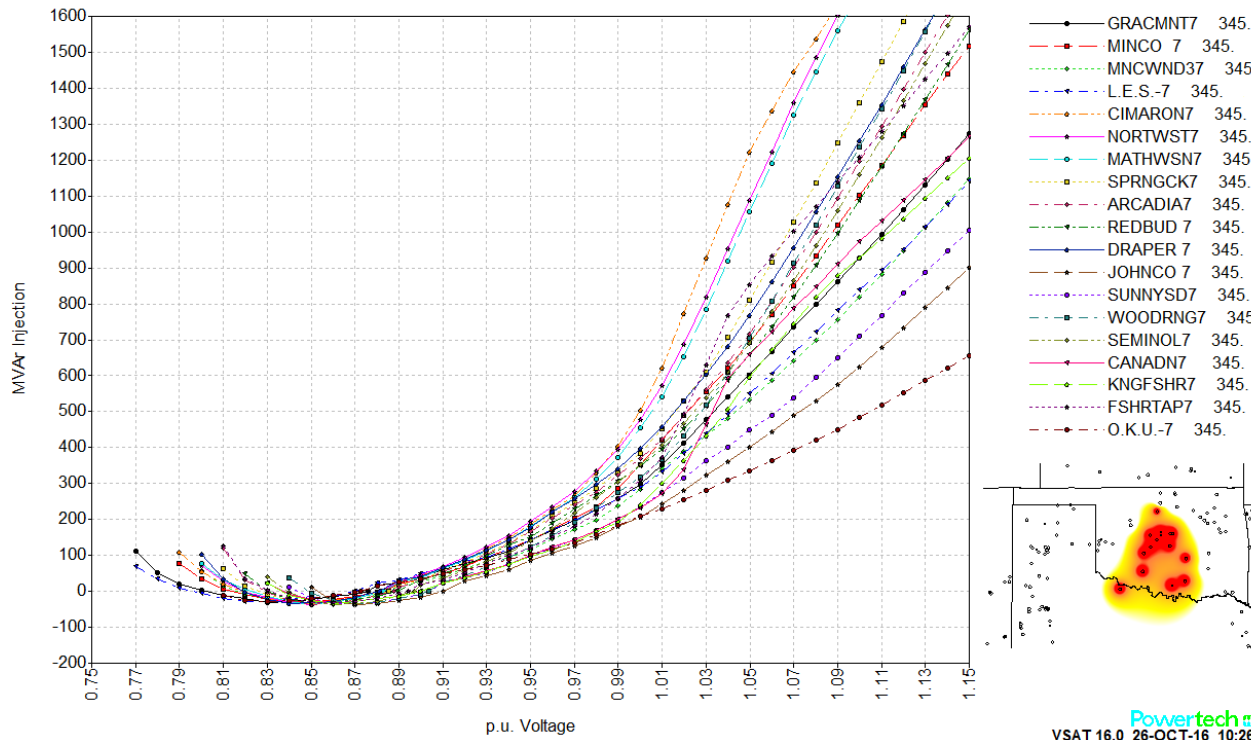

Figure 7.7.4 Q-V curve at the 95% transfer margin

7.7.3 Woodward Phase Shifter Effect

This Woodward phase shifter was not in-service in the original 2017 case. But to test its effectiveness, a separate simulation study assumes it is in-service and operates at 15 degree. Simulation shows that this phase shifter relieves WOODWRD4 - WINDRM4 138kV fto TATONGA7 - MATHWSN7 345kV overload successfully and increases security limit 90MW. The limiting contingency is unchanged.

7.7.4 Voltage Violations

After re-dispatch for relieving overloads, voltage violations were found in the base case for certain contingencies. The tables below show under voltage and over voltage violations. Note only the top 14 under-voltages and the top 35 over-voltages are shown in this report.

Bus Name	Area Name	Pre-ctg V(p.u.)	V (p.u.)	Criteria	Contingency	Notes
LE-TEXACO 3115.	SPS	1.001	0.768	0.9	CUNNINHAM 3115. - BUCKEYE_TP 3115.	
BUCKEYE 3115.	SPS	1.0041	0.768	0.9	CUNNINHAM 3115. - BUCKEYE_TP 3115.	
BUCKEYE_TP 3115.	SPS	1.0042	0.768	0.9	CUNNINHAM 3115. - BUCKEYE_TP 3115.	
LE-TXACO_TP3115.	SPS	1.0014	0.769	0.9	CUNNINHAM 3115. - BUCKEYE_TP 3115.	
LE-SANANDRS3115.	SPS	0.9996	0.769	0.9	CUNNINHAM 3115. - BUCKEYE_TP 3115.	
LE-TEXACO 3115.	SPS	1.001	0.796	0.9	BUCKEYE_TP 3115. - LE-TXACO_TP3115.	
LE-TXACO_TP3115.	SPS	1.0014	0.796	0.9	BUCKEYE_TP 3115. - LE-TXACO_TP3115.	
LE-SANANDRS3115.	SPS	0.9996	0.797	0.9	BUCKEYE_TP 3115. - LE-TXACO_TP3115.	
COWSKIN 138.	GRDA	0.9982	0.837	0.9	GROVE 4 138. - COWSKIN 138.	1
SLICKHILLS4 138.	WFEC	0.9755	0.863	0.9	TATONGA7 345. - MATHWSN7 345.	
BLUCAN14 138.	WFEC	0.9768	0.865	0.9	TATONGA7 345. - MATHWSN7 345.	
TIOGA 4 138.	WERE	0.9492	0.867	0.9	TIOGA 4 138. - ALTOONA4 138.	
LE-SANANDRS3115.	SPS	0.9996	0.868	0.9	LE-SANANDRS3115. - LE-TXACO_TP3115.	

Table 07.2: Under Voltage Violations

Itemized Notes from Under Voltage Table:

1. GRDA has indicated that (a) The load at Whitewater sub. (512743) was incorrectly modelled in the 2017 light load case. That load should be 4.7MW & 1MVar instead of 26MW & 5.3MVar. (b) The Cowskin auto transformer min/max voltage regulation (Vmin/Vmax) should be set at 0.9 and 1.1. The Vmin is currently being set at 1.0338pu in the cases which is too high. (c) No load is being connected to the 138kV side of the auto transformer under post contingent condition, the LTC permits tap changing to regulate the Cowskin 69kV bus

to 1.0338pu as indicated in the setting causing the voltage on the 138kV to drop below 0.9. This issue will be fixed in the 2017 MDWG model set.

Bus Name	Area Name	Pre-ctg V(p.u.)	V (p.u.)	Criteria	Contingency	Notes
SLEEPING 138.	WFEC	1.0484	1.143	1.05	IODINE 4 138. - MOORLND4 138.	
SLEEPING 138.	WFEC	1.0484	1.142	1.05	FTSUPPLY4 138. - IODINE 4 138.	
DENVTAP4 138.	AEPW	1.0189	1.142	1.05	T.NO.--4 138. - 46ST--E4 138.	
DENVR-E4 138.	AEPW	1.0197	1.142	1.05	T.NO.--4 138. - 46ST--E4 138.	
W.ED.-E4 138.	AEPW	1.0189	1.142	1.05	T.NO.--4 138. - 46ST--E4 138.	
46ST--E4 138.	AEPW	1.0176	1.142	1.05	T.NO.--4 138. - 46ST--E4 138.	
DENVTAP4 138.	AEPW	1.0189	1.140	1.05	DENVTAP4 138. - 46ST--E4 138.	
DENVR-E4 138.	AEPW	1.0197	1.140	1.05	DENVTAP4 138. - 46ST--E4 138.	
W.ED.-E4 138.	AEPW	1.0189	1.140	1.05	DENVTAP4 138. - 46ST--E4 138.	
FTSUPPLY4 138.	WFEC	1.043	1.138	1.05	IODINE 4 138. - MOORLND4 138.	
IODINE 4 138.	WFEC	1.029	1.138	1.05	IODINE 4 138. - MOORLND4 138.	
FTSUPPLY4 138.	WFEC	1.043	1.137	1.05	FTSUPPLY4 138. - IODINE 4 138.	
DENVR-E4 138.	AEPW	1.0197	1.130	1.05	DENVR-E4 138. - DENVTAP4 138.	
DENVR-C4 138.	AEPW	1.0364	1.127	1.05	DENVR-C4 138. - KENSH-W4 138.	
DENVR-C4 138.	AEPW	1.0364	1.124	1.05	CARSN-S4 138. - KENSH-W4 138.	
KENSH-W4 138.	AEPW	1.036	1.124	1.05	CARSN-S4 138. - KENSH-W4 138.	
DENVR-W4 138.	AEPW	1.0374	1.124	1.05	DENVR-W4 138. - S.S.---4 138.	
HOLLIS 4 138.	AEPW	1.0113	1.123	1.05	CHILD4WT 138. - HOLTP4WT 138.	
HOLTP4WT 138.	AEPW	1.0109	1.122	1.05	CHILD4WT 138. - HOLTP4WT 138.	
WELL 4WT 138.	AEPW	1.0143	1.121	1.05	CHILD4WT 138. - HOLTP4WT 138.	
SHAM 4WT 138.	AEPW	1.0205	1.117	1.05	CHILD4WT 138. - HOLTP4WT 138.	
SHAM 4WT 138.	AEPW	1.0205	1.096	1.05	CHILD4WT 138. - LAKEP4WT 138.	
WELL 4WT 138.	AEPW	1.0143	1.096	1.05	HOLTP4WT 138. - WELL 4WT 138.	
WELL 4WT 138.	AEPW	1.0143	1.096	1.05	CHILD4WT 138. - LAKEP4WT 138.	
HOLLIS 4 138.	AEPW	1.0113	1.095	1.05	CHILD4WT 138. - LAKEP4WT 138.	
SHAM 4WT 138.	AEPW	1.0205	1.095	1.05	HOLTP4WT 138. - WELL 4WT 138.	
DENVR-C4 138.	AEPW	1.0364	1.095	1.05	CARSN-S4 138. - T.P.S.-4 138.	
HOLTP4WT 138.	AEPW	1.0109	1.095	1.05	CHILD4WT 138. - LAKEP4WT 138.	
KENSH-W4 138.	AEPW	1.036	1.095	1.05	CARSN-S4 138. - T.P.S.-4 138.	
CARSN-S4 138.	AEPW	1.0357	1.095	1.05	CARSN-S4 138. - T.P.S.-4 138.	
CHILD4WT 138.	AEPW	1.0047	1.091	1.05	CHILD4WT 138. - LAKEP4WT 138.	
GORDON 7 115.	NPPD	1.0535	1.083	1.05	GORDON 7 115. - RUSHVIL7 115.	
SHAM 4WT 138.	AEPW	1.0205	1.082	1.05	WELL 4WT 138. - SHAM 4WT 138.	

Table 07.3: Over Voltage Violations

General AEP Note:

Some IDEV files have not been applied to the areas seeing voltage violations.

7.8 2021 45% WITH OUTAGES CASE

2021 45% with outages case can be dispatched (ignoring any overload below 110%) from base 11061.1MW to 11901.1MW (840MW increased), until it hits the thermal limit (over 110%) on Line TUPELO – TUPLOTP 138kV ftlo SUNNYSO - HUGO 345kV. If ignoring overloads, the contingency CIMARON - FSHRTAP 345kV causes voltage collapse at transfer to 11951.1MW (880MW increased). Modal analysis and contour maps show voltage collapse at central Oklahoma. The voltage contour map is in Figure 7.8.1.

In the base case, the net renewable MW reschedule is curtailing 71MW; the net thermal MW reschedule is curtailing 460MW. Both net renewable and net thermal MW changes due to the reschedule schemes have been balanced out by other renewable and thermal units in SPP footprint, so the net MW changes are negligible. After the MW balancing process, reschedule schemes proved to be no impact on the initial wind penetration level. The overload instances in base case are summarized in Table 7.8.1.

OVL #	Overloaded Branch	Area Name	MVA Rating	OVL %	Contingency			
1	PLANT_X 6230. - SUNDOWN	SPS	318.69	118.8	TOLK_WEST 6230. - YOAKUM 6230.			
2	6230			115.1	CROSSROADS 7345. - EDDY_CNTY 7345.			
3	TOLK_WEST 6230. - YOAKUM 6230	SPS	318.69	100.5				
4	WEBBTAP4 138. - OSAGE 4 138	AEPW-OKGE	180.00	114.6	CLEVLND7 345. - SOONER 7 345.			
5	HUTCH_S 3115. - MARTIN 3115	SPS	119.51	113.4	HIGHLAND_TP3115. - PANTEX_S 3115.			
6	LG-CLAUENE 3115. - TERRY_CNTY 3115	SPS	79.67	112.8	SUNDOWN 6230. - AMOCO_SS 6230.			
7	TOLK_WEST 6230. - YOAKUM 6230	SPS	318.69	101.5				
8	HUTCH_S 3115. - MARTIN 3115	SPS	119.51	112.7	MARTIN 3115. - PANTEX_N 3115.			
9	SCOTBLF7 115. - VICTRYH7 115	NPPD	120.00	112.2	STEGALL4 230. - STGXFMR4 230.			
10	HUTCH_S 3115. - MARTIN 3115	SPS	119.51	112.1	PANTEX_N 3115. - PANTEX_S 3115.			
11	COLMBUS7 115. - CRESTON7 115	NPPD	120.00	111.1	HOSKINS7 115. - NORFK.N7 115.			
12	PLANT_X 6230. - SUNDOWN 6230	SPS	318.69	110.2	TOLK_EAST 6230. - TUCO_INT 6230.			
13				107.4	LAMB_CNTY 3115. - HOCKLEY 3115.			
14				106.3	SUNDOWN 6230. - WOLFFORTH 6230.			
15				105.8	SWISHER 6230. - TUCO_INT 6230.			
16				104.6	HOCKLEY 3115. - LC-OPDYKE 3115.			
17				104.4	LC-OPDYKE 3115. - SUNDOWN 3115.			
18				103.6	SN_JUAN_TAP6230. - CHAVES_CNTY6230.			
19				103.5	TOLK 7345. - CROSSROADS 7345.			
20				POTASH_JCT 3115. - CARLSBAD 3115	SPS	79.67	103	CUNNIGHM_N 6230. - CUNNIGHM_S 6230.
21				PLANT_X 6230. - SUNDOWN 6230	SPS	318.69	102.5	

22	GRACMNT4 138. - ANADARK4 138	OKGE-WFEC	228.00	102.8	S.W.S.-4 138. - WASHITA4 138.
23	PLANT_X 6230. - SUNDOWN 6230	SPS	318.69	102.7	TUCO_INT 6230. - CARLISLE 6230.
24	LG-CLAUENE 3115. - TERRY_CNTY 3115	SPS	79.67	102	WOLFFORTH 3115. - TERRY_CNTY 3115.
25	LE-WEST_SUB3115. - LE-NRTH_INT3115	SPS	131.46	101.7	BUCKEYE_TP 3115. - LE-TXACO_TP3115.
26	PLANT_X 6230. - SUNDOWN 6230	SPS	318.69	101.7	TUCO_INT 6230. - JONES 6230.
27				101.2	SWISHER 6230. - NEWHART 6230.
28				101	OASIS 6230. - SN_JUAN_TAP6230.
29				100.2	TUCO_INT 6230. - HALE_WNDCL16230.
30				100	TOLK_WEST 6230. - LAMB_CNTY 6230.

Table 7.8.1 Overloads in base case

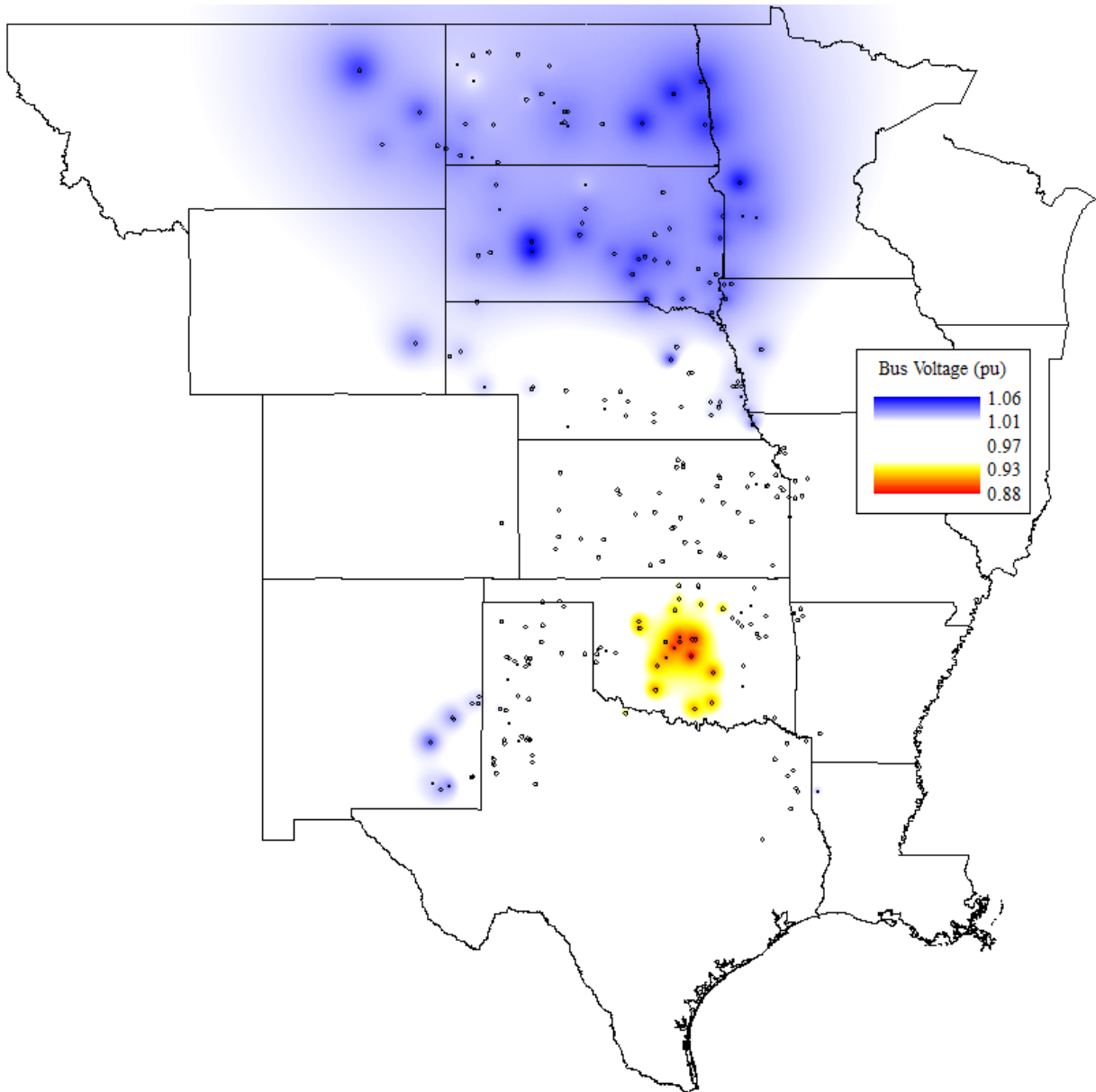

Figure 7.8.1 Voltage contour map at the last secure point prior voltage collapse

7.8.1 CONSTRAINT RE-DISPATCH ACTIONS

7.8.1.1 PLANT X- SUNDOWN 230kV ftlo TOLK WEST - YOAKUM 230kV

The reschedule scheme is in the following table.

<i>Type</i>	<i>Generator</i>	<i>Old</i>	<i>New</i>	<i>Switch On</i>
Thermal	TOLK_1 124.0	539.90	339.9	N/A
Thermal	TOLK_2 124.0	535.00	335.0	N/A

The reschedule scheme also relieves overload OVL # 2, 3, 7, 12 to 19.

7.8.1.2 SCOTBLF7 - VICTRYH7 115kV ftlo STEGALL4 - STGXFMR4 230kV

The reschedule scheme is in the following table.

<i>Type</i>	<i>Generator</i>	<i>Old</i>	<i>New</i>	<i>Switch On</i>
Thermal	LARAM31G 24.0	611.0	511.0	N/A

7.8.1.3 HUTCH S - MARTIN 115kV ftlo HIGHLAND TP3 - PANTEX S 115kV

The reschedule scheme in the following table:

<i>Type</i>	<i>Generator</i>	<i>Old</i>	<i>New</i>	<i>Switch On</i>
NDVER	CARSON_SUB 113.8	8.01	4.00	N/A
NDVER	MAJSTC-WTG110.69	63.28	30.00	N/A
NDVER	MAJSTC-WTG210.69	63.89	30.00	N/A

The reschedule scheme also relieves overload OVL # 8 and 10

7.8.1.4 COLMBUS7 - CRESTON7 115kV ftlo HOSKINS7 - NORFK.N7 115kV

As NORFK.N7 115kV experience low voltage (less than 0.9pu), the reschedule scheme is to turn on shunts at NORFK.N9 and NORFOLK9 for total 21.6MVar.

7.8.1.5 WEBBTAP - OSAGE 138kV ftlo CLEVLND7 - SOONER 7 345kV

The reschedule scheme is in the following table.

<i>Type</i>	<i>Generator</i>	<i>Old</i>	<i>New</i>	<i>Switch On</i>
Thermal	SOONER1G 22.0	200.85	OFF	OFF

This overload was completely relieved at the base case, but it became back as an issue during the transfer.

7.8.1.6 LG-CLAUENE - TERRY CNTY 115kV ftlo SUNDOWN - AMOCO SS 230kV

The reschedule scheme in the following table:

<i>Type</i>	<i>Generator</i>	<i>Old</i>	<i>New</i>	<i>Switch On</i>
Thermal	MUSTANG_1 113.8	0	100.00	Yes
Thermal	MUSTANG_3 122.0	0	100.00	Yes
Thermal	MUSTANG_8S 34.5	0	30.00	Yes

The reschedule scheme also relieves overload OVL # 24

7.8.2 V-P Curve and Q-V Curves

Critical 345kV above buses were identified using modal analysis result. V-P curve has been plotted for those critical buses in Figure 7.8.2.

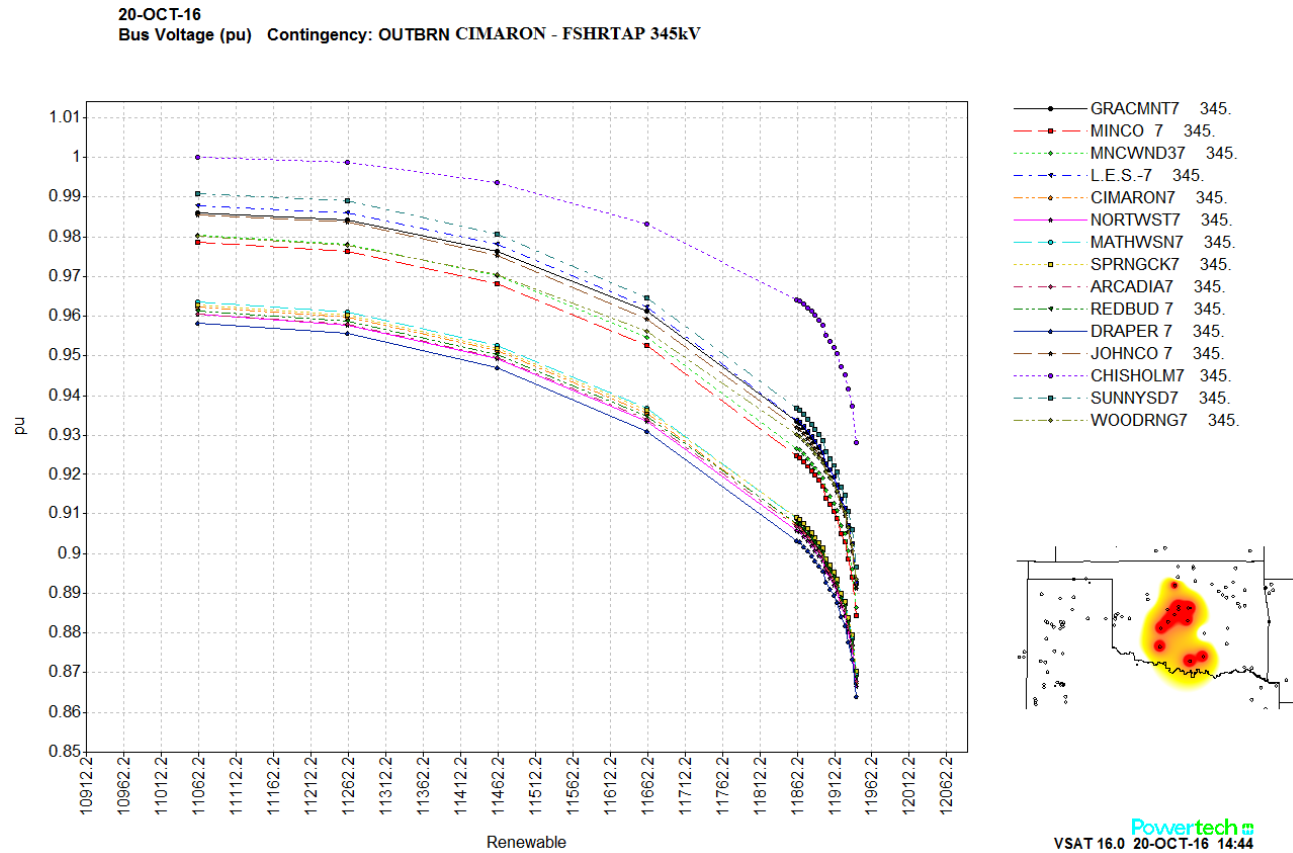

Figure 7.8.2 V-P curves of 345kV buses near stability limit location

The Q-V curve at the base transfer point (11061.1MW) is shown in Figure 7.8.3. The Q-V curve at 95% security margin (11061.1+880*95%=11897.1MW) is shown in Figure 7.8.4.

20-OCT-16
Transfer Renewable to The
VQ Curve

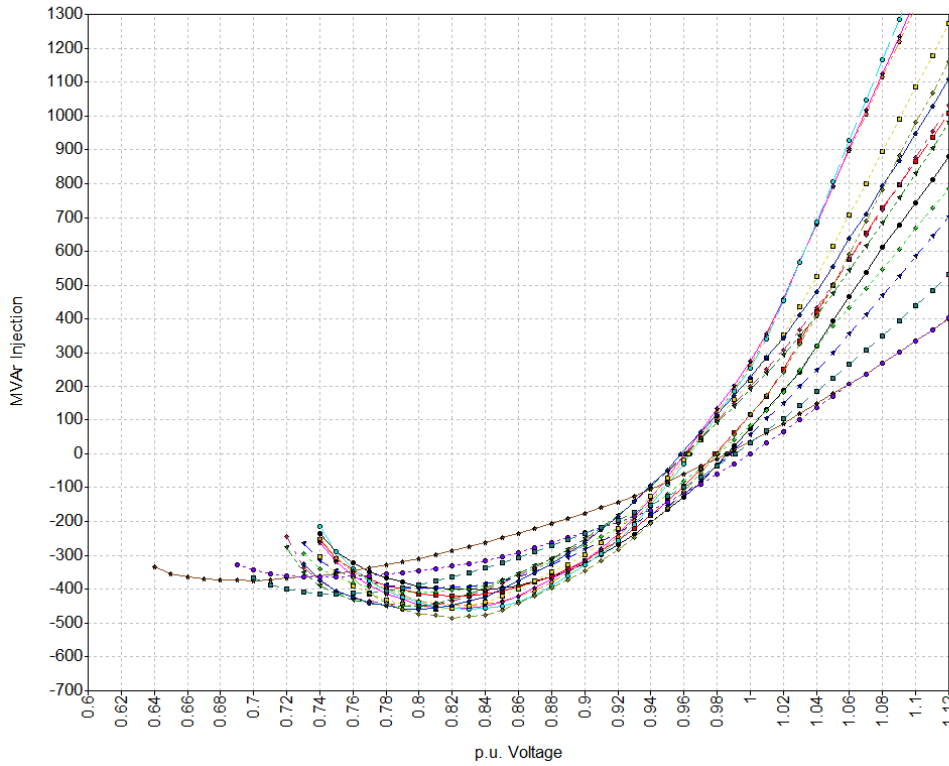

Figure 7.8.3 Q-V curve at the base transfer

20-OCT-16
Transfer Renewable to The
VQ Curve

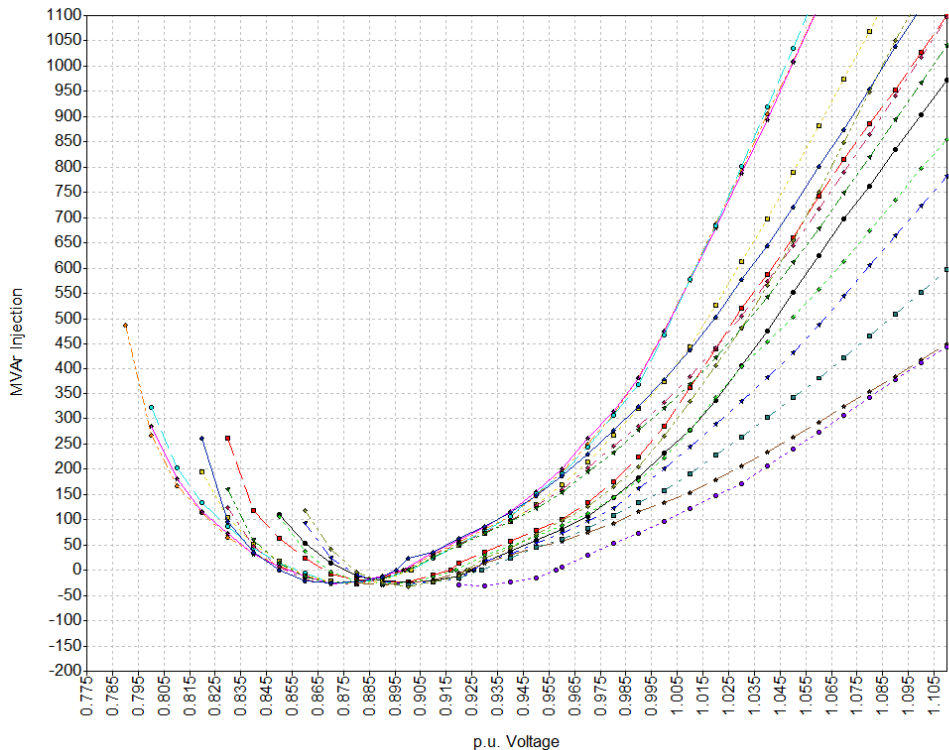

Figure 7.8.4 Q-V curve at the 95% transfer margin

7.8.3 Voltage Violations

After re-dispatch for relieving overloads, voltage violations were found in the base case for certain contingencies. The tables below show under voltage and over voltage violations. Note only the top 47 over-voltages are shown in this report.

Bus Name	Area Name	Pre-ctg V(p.u.)	V (p.u.)	Criteria	Contingency	Notes
LE-TEXACO 3115.	SPS	1.001	0.700	0.9	BUCKEYE_TP 3115. - LE-TXACO_TP3115.	
LE-TXACO_TP3115.	SPS	1.0014	0.701	0.9	BUCKEYE_TP 3115. - LE-TXACO_TP3115.	
LE-SANANDRS3115.	SPS	0.9996	0.701	0.9	BUCKEYE_TP 3115. - LE-TXACO_TP3115.	
BLUEBUTE-MK7115.	WAPA	0.9923	0.821	0.9	BEARCREK-MK7115. - ROUNDUP 7115.	
BEARCREK-MK7115.	WAPA	1.011	0.840	0.9	BEARCREK-MK7115. - ROUNDUP 7115.	1
OAKDALE -MK7115.	WAPA	1.0073	0.842	0.9	BEARCREK-MK7115. - ROUNDUP 7115.	1
DUNNING7-CP7115.	WAPA	1.0185	0.842	0.9	MALLARD7 115. - RUTHVILL-CP7115.	
KILLDEER-MK7115.	WAPA	1.0081	0.856	0.9	BEARCREK-MK7115. - ROUNDUP 7115.	1
KILDEER7 115.	WAPA	1.0082	0.857	0.9	BEARCREK-MK7115. - ROUNDUP 7115.	1
HARAM -CP7115.	WAPA	1.02	0.873	0.9	MALLARD7 115. - RUTHVILL-CP7115.	
WSTBOTJC-CP7115.	WAPA	1.0204	0.873	0.9	MALLARD7 115. - RUTHVILL-CP7115.	
BOTTNO 7 115.	WAPA	1.02	0.882	0.9	MALLARD7 115. - RUTHVILL-CP7115.	
BOTNO_SE-CP7115.	WAPA	1.0204	0.883	0.9	MALLARD7 115. - RUTHVILL-CP7115.	

Table 0.2: Under Voltage Violations

Itemized Notes from Under Voltage Table:

1. Manual check, voltage OK for N-1. (Appears like results from N-2)

Bus Name	Area Name	Pre-ctg V(p.u.)	V (p.u.)	Criteria	Contingency	Notes
SLEEPING 138.	WFEC	1.0484	1.157	1.05	IODINE 4 138. - MOORLND4 138.	
SLEEPING 138.	WFEC	1.0484	1.156	1.05	FTSUPPLY4 138. - IODINE 4 138.	
DENVTAP4 138.	AEPW	1.0189	1.156	1.05	T.NO.--4 138. - 46ST--E4 138.	
DENVR-E4 138.	AEPW	1.0197	1.156	1.05	T.NO.--4 138. - 46ST--E4 138.	
W.ED.-E4 138.	AEPW	1.0189	1.156	1.05	T.NO.--4 138. - 46ST--E4 138.	
46ST--E4 138.	AEPW	1.0176	1.156	1.05	T.NO.--4 138. - 46ST--E4 138.	
DENVTAP4 138.	AEPW	1.0189	1.155	1.05	DENVTAP4 138. - 46ST--E4 138.	
DENVR-E4 138.	AEPW	1.0197	1.155	1.05	DENVTAP4 138. - 46ST--E4 138.	
W.ED.-E4 138.	AEPW	1.0189	1.155	1.05	DENVTAP4 138. - 46ST--E4 138.	
FTSUPPLY4 138.	WFEC	1.043	1.152	1.05	IODINE 4 138. - MOORLND4 138.	
IODINE 4 138.	WFEC	1.029	1.151	1.05	IODINE 4 138. - MOORLND4 138.	
FTSUPPLY4 138.	WFEC	1.043	1.151	1.05	FTSUPPLY4 138. - IODINE 4 138.	
DENVR-E4 138.	AEPW	1.0197	1.144	1.05	DENVR-E4 138. - DENVTAP4 138.	
DENVR-C4 138.	AEPW	1.0364	1.135	1.05	DENVR-C4 138. - KENSH-W4 138.	
CARSN-C4 138.	AEPW	1.034	1.134	1.05	UNIONAV4 138. - CARSN-C4 138.	

DENVR-C4 138.	AEPW	1.0364	1.134	1.05	CARSN-S4 138. - T.P.S.-4 138.	
CARSN-S4 138.	AEPW	1.0357	1.134	1.05	CARSN-S4 138. - T.P.S.-4 138.	
KENSH-W4 138.	AEPW	1.036	1.134	1.05	CARSN-S4 138. - T.P.S.-4 138.	
DENVR-W4 138.	AEPW	1.0374	1.133	1.05	DENVR-W4 138. - S.S.--4 138.	
CARSN-N4 138.	AEPW	1.0362	1.132	1.05	CARSN-N4 138. - CARSONT4 138.	
DENVR-C4 138.	AEPW	1.0364	1.131	1.05	CARSN-S4 138. - KENSH-W4 138.	
KENSH-W4 138.	AEPW	1.036	1.131	1.05	CARSN-S4 138. - KENSH-W4 138.	
CARSN-N4 138.	AEPW	1.0362	1.125	1.05	WED-TAP4 138. - CARSONT4 138.	
CARSONT4 138.	AEPW	1.0359	1.125	1.05	WED-TAP4 138. - CARSONT4 138.	
W.ED.-W4 138.	AEPW	1.0359	1.125	1.05	WED-TAP4 138. - CARSONT4 138.	
PARAGLD5 161.	SWPA	0.9873	1.121	1.05	PARAGLD5 161. - CENTR H5 161.	
CARSN-C4 138.	AEPW	1.034	1.109	1.05	CARSN-T4 138. - UNIONAV4 138.	
UNIONAV4 138.	AEPW	1.0338	1.109	1.05	CARSN-T4 138. - UNIONAV4 138.	
PARAGLD5 161.	SWPA	0.9873	1.105	1.05	CENTR H5 161. - JONESBO5 161.	
CENTR H5 161.	SWPA	0.9858	1.104	1.05	CENTR H5 161. - JONESBO5 161.	
RATLIFF4 138.	OKGE	1.0094	1.104	1.05	RATLIFF4 138. - CARTRCO4 138.	1
PHILIP 7 115.	WAPA	1.0658	1.097	1.05	PHILIP 4 230. - PHILTAP4 230.	
GORDON 7 115.	NPPD	1.0535	1.096	1.05	GORDON 7 115. - RUSHVIL7 115.	
GORDON 7 115.	NPPD	1.0535	1.093	1.05	CHADRON7 115. - RUSHVIL7 115.	
NEVADA 5 161.	GMO	1.0052	1.092	1.05	5BUTLER 161. - NEVADA 5 161.	
RUSHVIL7 115.	NPPD	1.0505	1.092	1.05	CHADRON7 115. - RUSHVIL7 115.	
HOLLIS 4 138.	AEPW	1.0113	1.089	1.05	CHILD4WT 138. - HOLTP4WT 138.	
HOLTP4WT 138.	AEPW	1.0109	1.088	1.05	CHILD4WT 138. - HOLTP4WT 138.	
WELL 4WT 138.	AEPW	1.0143	1.087	1.05	CHILD4WT 138. - HOLTP4WT 138.	
SHAN-SD7 115.	WAPA	1.0516	1.085	1.05	GORDON 7 115. - RUSHVIL7 115.	
SHAM 4WT 138.	AEPW	1.0205	1.083	1.05	CHILD4WT 138. - HOLTP4WT 138.	
SHAN-SD7 115.	WAPA	1.0516	1.082	1.05	CHADRON7 115. - RUSHVIL7 115.	
KENNETT5 161.	SWPA	1.0017	1.082	1.05	PARAGLD5 161. - CENTR H5 161.	
MOORHED7 115.	WAPA	1.0567	1.081	1.05	SHEYNNE4 230. - FARGO 4 230.	

Table 08.3: Over Voltage Violations

Itemized Notes from Over Voltage Table:

1. This over-voltage is more outage related. In addition to the contingency, bus PRARPNT4 138kV is already outaged in the power flow making this condition worse than N-1. In this case Ratliff 138kV is backfed by the long 69kV radial line from Healdton 138kV substation. . Given the weak system it is connected to in this configuration, the switching of the CAPs at Ratliff 138kV would create significant voltage deviation.

General AEP Note:

Some IDEV files have not been applied to the areas seeing voltage violations.

7.9 2021 45% WITHOUT OUTAGES CASE

2021 45% without outages case can be dispatched from base 11048.7MW to maximum transfer 14747.8MW without hitting voltage collapse, if ignoring overload below 107%. So analysis on the 60% penetration case was also performed. The overload instances in base case are summarized in Table 7.9.1. During the transfer, there were some significant overloading (overload 110% above) issues that have been relieved or mitigated by rescheduling the wind and thermal units.

In the base case, the net renewable MW reschedule is curtailing 43MW; the net thermal MW reschedule is increasing 331MW. Both net renewable and net thermal MW changes due to the reschedule schemes have been balanced out by other renewable and thermal units in SPP footprint, so the net MW changes are negligible. After the MW balancing process, reschedule schemes proved to be no impact on the initial wind penetration level.

OVL #	Overloaded Branch	Area Name	MVA Rating	OVL %	Contingency
1	PLANT_X 6230. - SUNDOWN 6230	SPS	318.69	117	TOLK_WEST 6230. - YOAKUM 6230.
2				114.5	CROSSROADS 7345. - EDDY_CNTY 7345.
3	TOLK_WEST 6230. - YOAKUM 6230	SPS	318.69	100.2	
4	HUTCH_S 3115. - MARTIN 3115	SPS	119.51	113.4	HIGHLAND_TP3115. - PANTEX_S 3115.
5				112.8	MARTIN 3115. - PANTEX_N 3115.
6				112.2	PANTEX_N 3115. - PANTEX_S 3115.
7	LG-CLAUENE 3115. - TERRY_CNTY 3115	SPS	79.67	111.4	SUNDOWN 6230. - AMOCO_SS 6230.
8	TOLK_WEST 6230. - YOAKUM 6230	SPS	318.69	100.2	
9	PLANT_X 6230. - SUNDOWN 6230	SPS	318.69	108.8	TOLK_EAST 6230. - TUCO_INT 6230.
10				106	LAMB_CNTY 3115. - HOCKLEY 3115.
11				105.5	SUNDOWN 6230. - WOLFFORTH 6230.
12				104.5	SWISHER 6230. - TUCO_INT 6230.
13	SCOTBLF7 115. - VICTRYH7 115	NPPD	120.00	104.4	STEGALL4 230. - STGXFMR4 230.
14	PLANT_X 6230. - SUNDOWN 6230	SPS	318.69	103.3	HOCKLEY 3115. - LC-OPDYKE 3115.
15				103.1	LC-OPDYKE 3115. - SUNDOWN 3115.
16				102.9	TOLK 7345. - CROSSROADS 7345.
17				102.7	SN_JUAN_TAP6230. - CHAVES_CNTY6230.
18	LE-WEST_SUB3115. - LE-NRTH_INT3115	SPS	131.46	102.1	BUCKEYE_TP 3115. - LE-TXACO_TP3115.
19	LG-CLAUENE 3115. - TERRY_CNTY 3115	SPS	79.67	100.9	WOLFFORTH 3115. - TERRY_CNTY 3115.
20	PLANT_X 6230. - SUNDOWN 6230	SPS	318.69	100.7	TUCO_INT 6230. - CARLISLE 6230.
21				100.1	OASIS 6230. - SN_JUAN_TAP6230.

Table 7.9.1 Overloads in base case

7.9.1 Overload Issues in Base Case

7.9.1.1 PLANT X- SUNDOWN 230kV ftlo TOLK WEST - YOAKUM 230kV

The reschedule scheme is in the following table.

<i>Type</i>	<i>Generator</i>	<i>Old</i>	<i>New</i>	<i>Switch On</i>
Thermal	TOLK_1 124.0	535.00	335.00	N/A
Thermal	TOLK_2 124.0	535.02	335.02	N/A

The reschedule scheme also relieves overload OVL # 2, 9 to 12, 14 to 17, 20, and 21.

7.9.1.2 HUTCH S - MARTIN 115kV ftlo HIGHLAND TP3 - PANTEX S 115kV

The reschedule scheme in the following table:

<i>Type</i>	<i>Generator</i>	<i>Old</i>	<i>New</i>	<i>Switch On</i>
NDVER	CARSON_SUB 113.8	8.01	4.00	N/A
NDVER	MAJSTC-WTG110.69	63.28	50.00	N/A
NDVER	MAJSTC-WTG210.69	63.89	50.00	N/A

The reschedule scheme also relieves overload OVL # 5 and 6

7.9.1.3 LG-CLAUENE - TERRY CNTY 115kV ftlo SUNDOWN - AMOCO SS 230kV

The reschedule scheme in the following table:

<i>Type</i>	<i>Generator</i>	<i>Old</i>	<i>New</i>	<i>Switch On</i>
Thermal	MUSTANG_1 113.8	0	100.00	Yes
Thermal	MUSTANG_3 122.0	0	100.00	Yes
Thermal	MUSTANG_8S 34.5	0	30.00	Yes

The reschedule scheme also relieves overload OVL # 19

7.9.1.4 SCOTBLF7 - VICTRYH7 115kV ftlo STEGALL4 - STGXFMR4 230kV

The reschedule scheme is in the following table.

<i>Type</i>	<i>Generator</i>	<i>Old</i>	<i>New</i>	<i>Switch On</i>
Thermal	LARAM31G 24.0	611.0	450.0	N/A

7.9.2 Overload Issues During Transfer

The following overload instances were all during the transfer. Some of rescheduling schemes are holding generation output to a certain level during the transfer, while others are reset generation from the base case.

7.9.2.1 BC-KELLEY - BC-EARTH 115kV ftlo CASTRO CNTY3 - NEWHART 115kV

The reschedule scheme is to hold DVER wind farm, BETHEL_WND1134.5 to 270 MW.

<i>Type</i>	<i>Generator</i>	<i>Old</i>	<i>New</i>	<i>Switch On</i>
DVER	BETHEL_WND1134.5	253.72	270.00	N/A

7.9.2.2 GRACMNT – ANADARK 138kV ftlo S.W.S.-4 - WASHITA4 138kV

The reschedule scheme is to hold nearby thermal Gen at GENCO1 4 13.8kV to 29.631MW, and curtail DVER at BLUCAN14:

<i>Type</i>	<i>Generator</i>	<i>Old</i>	<i>New</i>	<i>Switch On</i>
DVER	BLUCAN14 138., ‘2’	122.86	95.00	N/A

7.9.2.3 N HAYS3 - VINETAP3 115kV ftlo KNOLL 6 - POSTROCK6 230kV

The reschedule scheme is to hold on thermal gen GMECG2 1 13.8, ID ‘10’, ‘11’, ‘12’

7.9.2.4 SWEETWT6 - DS-#6 115kV ftlo O.K.U. - L.E.S. 345kV

The reschedule scheme is to hold three nearby wind BUFFCK1 34.5, DEMPSEY1 34.5, and ROARK1 34.5.

7.9.2.5 BUTLER4 - ALTOONA4 138kV ftlo CANEYRV7 - NEOSHO 7 345kV

This line is parallel with 345kV line from Caney River to Neosho, so if contingency occurs on this 345kV line, the Bulter – Altoona line starts to experience overload when the transfer renewables beyond 13048.7MW (2000MW increased from the base). The overload gets severe during the transfer and reaches 111.4% at the max transfer (14747.8MW). There is no simple dispatch scheme found to relieve this overload. There is a way to relieve this overload, but thirty plus wind farms need to be curtailed. As the overloading is not severe, so the current solution is to ignore this overload.

7.9.3 Voltage Violations

After re-dispatch for relieving overloads, voltage violations were found in the base case for certain contingencies. The tables below show under voltage and over voltage violations. Note only the top 61 over-voltages are shown in this report.

<i>Bus Name</i>	<i>Area Name</i>	<i>Pre-ctg V(p.u.)</i>	<i>V (p.u.)</i>	<i>Criteria</i>	<i>Contingency</i>	<i>Notes</i>
-----------------	------------------	------------------------	-----------------	-----------------	--------------------	--------------

LE-TEXACO 3115.	SPS	1.001	0.701	0.9	BUCKEYE_TP 3115. - LE-TXACO_TP3115.
LE-TXACO_TP3115.	SPS	1.0014	0.701	0.9	
LE-SANANDRS3115.	SPS	0.9996	0.702	0.9	
LE-SANANDRS3115.	SPS	0.9996	0.830	0.9	LE-SANANDRS3115. - LE-TXACO_TP3115.
DUNNING7-CP7115.	WAPA	1.0185	0.840	0.9	MALLARD7 115. - RUTHVILL-CP7115.
HARAM -CP7115.	WAPA	1.02	0.870	0.9	
WSTBOTJC-CP7115.	WAPA	1.0204	0.871	0.9	
BOTTNO 7 115.	WAPA	1.02	0.880	0.9	
BOTNO_SE-CP7115.	WAPA	1.0204	0.881	0.9	

Table 0.2: Under Voltage Violations

Bus Name	Area Name	Pre-ctg V(p.u.)	V (p.u.)	Criteria	Contingency	Notes
DENVTAP4 138.	AEPW	1.0189	1.162	1.05	T.NO.--4 138. - 46ST--E4 138.	
DENVR-E4 138.	AEPW	1.0197	1.162	1.05	T.NO.--4 138. - 46ST--E4 138.	
W.ED.-E4 138.	AEPW	1.0189	1.162	1.05	T.NO.--4 138. - 46ST--E4 138.	
46ST--E4 138.	AEPW	1.0176	1.162	1.05	T.NO.--4 138. - 46ST--E4 138.	
DENVTAP4 138.	AEPW	1.0189	1.161	1.05	DENVTAP4 138. - 46ST--E4 138.	
DENVR-E4 138.	AEPW	1.0197	1.161	1.05	DENVTAP4 138. - 46ST--E4 138.	
W.ED.-E4 138.	AEPW	1.0189	1.161	1.05	DENVTAP4 138. - 46ST--E4 138.	
SLEEPING 138.	WFEC	1.0484	1.161	1.05	IODINE 4 138. - MOORLND4 138.	
SLEEPING 138.	WFEC	1.0484	1.160	1.05	FTSUPPLY4 138. - IODINE 4 138.	
FTSUPPLY4 138.	WFEC	1.043	1.156	1.05	IODINE 4 138. - MOORLND4 138.	
IODINE 4 138.	WFEC	1.029	1.155	1.05	IODINE 4 138. - MOORLND4 138.	
FTSUPPLY4 138.	WFEC	1.043	1.155	1.05	FTSUPPLY4 138. - IODINE 4 138.	
DENVR-E4 138.	AEPW	1.0197	1.150	1.05	DENVR-E4 138. - DENVTAP4 138.	
DENVR-C4 138.	AEPW	1.0364	1.143	1.05	DENVR-C4 138. - KENSH-W4 138.	
CARSN-C4 138.	AEPW	1.034	1.142	1.05	UNIONAV4 138. - CARSN-C4 138.	
DENVR-C4 138.	AEPW	1.0364	1.142	1.05	CARSN-S4 138. - T.P.S.-4 138.	
CARSN-S4 138.	AEPW	1.0357	1.142	1.05	CARSN-S4 138. - T.P.S.-4 138.	
KENSH-W4 138.	AEPW	1.036	1.142	1.05	CARSN-S4 138. - T.P.S.-4 138.	
DENVR-W4 138.	AEPW	1.0374	1.141	1.05	DENVR-W4 138. - S.S.--4 138.	
CARSN-N4 138.	AEPW	1.0362	1.140	1.05	CARSN-N4 138. - CARSONT4 138.	
DENVR-C4 138.	AEPW	1.0364	1.139	1.05	CARSN-S4 138. - KENSH-W4 138.	
KENSH-W4 138.	AEPW	1.036	1.139	1.05	CARSN-S4 138. - KENSH-W4 138.	
CARSN-N4 138.	AEPW	1.0362	1.133	1.05	WED-TAP4 138. - CARSONT4 138.	
CARSONT4 138.	AEPW	1.0359	1.133	1.05	WED-TAP4 138. - CARSONT4 138.	
W.ED.-W4 138.	AEPW	1.0359	1.133	1.05	WED-TAP4 138. - CARSONT4 138.	
PARAGLD5 161.	SWPA	0.9873	1.121	1.05	PARAGLD5 161. - CENTR H5 161.	
CARSN-C4 138.	AEPW	1.034	1.117	1.05	CARSN-T4 138. - UNIONAV4 138.	
UNIONAV4 138.	AEPW	1.0338	1.117	1.05	CARSN-T4 138. - UNIONAV4 138.	
PARAGLD5 161.	SWPA	0.9873	1.105	1.05	CENTR H5 161. - JONESBO5 161.	
CENTR H5 161.	SWPA	0.9858	1.104	1.05	CENTR H5 161. - JONESBO5 161.	

HOLLIS 4 138.	AEPW	1.0113	1.088	1.05	CHILD4WT 138. - HOLTP4WT 138.	
HOLTP4WT 138.	AEPW	1.0109	1.088	1.05	CHILD4WT 138. - HOLTP4WT 138.	
WELL 4WT 138.	AEPW	1.0143	1.086	1.05	CHILD4WT 138. - HOLTP4WT 138.	
ENOGEXT4 138.	AEPW	1.0315	1.086	1.05	LEQUIRE4 138. - ENOGEXT4 138.	
ENOGEX 4 138.	AEPW	1.0314	1.086	1.05	LEQUIRE4 138. - ENOGEXT4 138.	
ROAKTAP4 138.	AEPW	1.0325	1.086	1.05	LEQUIRE4 138. - ENOGEXT4 138.	
REDOK-4 138.	AEPW	1.0332	1.086	1.05	LEQUIRE4 138. - ENOGEXT4 138.	
ROAKPMP4 138.	AEPW	1.0324	1.085	1.05	LEQUIRE4 138. - ENOGEXT4 138.	
REDOK-4 138.	AEPW	1.0332	1.083	1.05	EUFAULA4 138. - STIGLRT4 138.	
ROAKTAP4 138.	AEPW	1.0325	1.083	1.05	EUFAULA4 138. - STIGLRT4 138.	
REDOK-4 138.	AEPW	1.0332	1.083	1.05	REDOK-4 138. - ROAKTAP4 138.	
ROAKPMP4 138.	AEPW	1.0324	1.083	1.05	EUFAULA4 138. - STIGLRT4 138.	
ENOGEXT4 138.	AEPW	1.0315	1.083	1.05	EUFAULA4 138. - STIGLRT4 138.	
ENOGEX 4 138.	AEPW	1.0314	1.083	1.05	EUFAULA4 138. - STIGLRT4 138.	
LEQUIRE4 138.	AEPW	1.0315	1.083	1.05	EUFAULA4 138. - STIGLRT4 138.	
REDOK-4 138.	AEPW	1.0332	1.083	1.05	LEQUIRE4 138. - STIGLRT4 138.	
ROAKTAP4 138.	AEPW	1.0325	1.083	1.05	LEQUIRE4 138. - STIGLRT4 138.	
STIGLRT4 138.	AEPW	1.0297	1.083	1.05	EUFAULA4 138. - STIGLRT4 138.	
ENOGEXT4 138.	AEPW	1.0315	1.083	1.05	LEQUIRE4 138. - STIGLRT4 138.	
LEQUIRE4 138.	AEPW	1.0315	1.083	1.05	LEQUIRE4 138. - STIGLRT4 138.	
ENOGEX 4 138.	AEPW	1.0314	1.083	1.05	LEQUIRE4 138. - STIGLRT4 138.	
STIGLER4 138.	AEPW	1.0295	1.083	1.05	EUFAULA4 138. - STIGLRT4 138.	
ROAKPMP4 138.	AEPW	1.0324	1.082	1.05	LEQUIRE4 138. - STIGLRT4 138.	
SHAM 4WT 138.	AEPW	1.0205	1.082	1.05	CHILD4WT 138. - HOLTP4WT 138.	
KENNETT5 161.	SWPA	1.0017	1.082	1.05	PARAGLD5 161. - CENTR H5 161.	
GORDON 7 115.	NPPD	1.0535	1.082	1.05	GORDON 7 115. - RUSHVIL7 115.	
REDOK-4 138.	AEPW	1.0332	1.081	1.05	ENOGEXT4 138. - ROAKTAP4 138.	
ROAKTAP4 138.	AEPW	1.0325	1.081	1.05	ENOGEXT4 138. - ROAKTAP4 138.	
ROAKPMP4 138.	AEPW	1.0324	1.080	1.05	ENOGEXT4 138. - ROAKTAP4 138.	

Table 9.3.3: Over Voltage Violations

General AEP Note:

Some IDEV files have not been applied to the areas seeing voltage violations.

7.10 2021 60% WITHOUT OUTAGES CASE

2021 60% without outages case can be dispatched from base 14747.8MW to maximum transfer at 15550MW without hitting voltage collapse (if ignore overload below 109%). A few contingencies cause low voltage (as low as 0.6pu). A few buses in basecase have high voltage (higher than 1.05pu but less than 1.07pu). The overload instances in base case are summarized in Table 7.10.1. During the transfer there are a few significant overload issues.

In the base case, the net renewable MW reschedule is increasing 186MW; the net thermal MW reschedule is curtailing 283MW. Both net renewable and net thermal MW changes due to the

reschedule schemes have been balanced out by other renewable and thermal units in SPP footprint, so the net MW changes are negligible. After the MW balancing process, reschedule schemes proved to be no impact on the initial wind penetration level. Swing bus at 1BR FERRY N322.0 has relatively very small MVA reserve so the base MVA has increased from 1332MVA to 1432MVA to prevent it from being saturated during the powerflow solution.

OVL #	Overloaded Branch	Area Name	MVA Rating	OVL %	Contingency
1	HUTCH_S 3115. - MARTIN 3115	SPS	119.51	131.3	HIGHLAND_TP3115. - PANTEX_S 3115.
2				129.6	MARTIN 3115. - PANTEX_N 3115.
3				129	PANTEX_N 3115. - PANTEX_S 3115.
4				115.7	HIGHLAND_TP3115. - ASARCO_TP 3115.
5				115.6	ASARCO_TP 3115. - NICHOLS 3115.
6	MARSHAL3 115. - SMITTYV3 115	WERE	92.00	113.9	HARBINE7 115. - STEELEC7 115.
7	BAILEYV3 115. - SMITTYV3 115	WERE	92.00	113	
8	BAILEYV3 115. - SENECA 3 115	WERE	92.00	110.8	
9	BRADLEY2 138. - RUSHSPG4 138	WFEC	65.00	108.3	NAPLESTP 138. - CORN TP4 138.
10	BRADLEY2 138. - LNDSYSW2 138	WFEC	65.00	107.9	
11	BC-EARTH 3115. - PLANT_X 3115	SPS	154.00	106.8	CASTRO_CNTY3115. - NEWHART 3115.
12	BC-KELLEY +3115. - BC-EARTH 3115	SPS	160.00	105.4	
13	BRADLEY2 138. - RUSHSPG4 138	WFEC	65.00	106.6	NAPLESTP 138. - PAYNE 138.
14	BRADLEY2 138. - LNDSYSW2 138	WFEC	65.00	106.2	
15	HEREFORD 3115. - DS-#6 3115	SPS	79.67	105.9	DEAFSMITH 6230. - PLANT_X 6230.
16	CASTRO_CNTY3115. - NEWHART 3115	SPS	159.94	105.8	CASTRO_CNTY3115. - BC-KELLEY +3115.
17				104.5	BC-KELLEY +3115. - BC-EARTH 3115.
18	NEOSHO 5 161. - RIV4525 161	WERE-EMDE	223.00	103.5	7BLACKBERRY 345. - NEOSHO 7 345.
19	CASTRO_CNTY3115. - NEWHART 3115	SPS	159.94	102.1	BC-EARTH 3115. - PLANT_X 3115.
20	SMOKYHL6 230. - SUMMIT 6 230	MIDW-WERE	350.00	101.3	POSTROCK7 345. - AXTELL 3 345.
21	HALE_CNTY 3115. - TUCO_INT 3115	SPS	79.67	100.9	SWISHER 6230. - TUCO_INT 6230.

Table 7.10.1 Overloads in base case

7.10.1 Overload Issues in Base Case

7.10.1.1 HUTCH S - MARTIN 115kV ftlo HIGHLAND TP3 - PANTEX S 115kV

The reschedule scheme in the following table:

<i>Type</i>	<i>Generator</i>	<i>Old</i>	<i>New</i>	<i>Switch On</i>
NDVER	CARSON_SUB 113.8	9.19	4.00	N/A
NDVER	MAJSTC-WTG110.69	73.05	50.00	N/A
NDVER	MAJSTC-WTG210.69	73.05	50.00	N/A

The reschedule scheme also relieves overload OVL # 2 to 5

7.10.1.2 MARSHAL - SMITTYV 115kV ftlo HARBINE - STEELEC 115kV

The reschedule scheme in the following table:

<i>Type</i>	<i>Generator</i>	<i>Old</i>	<i>New</i>	<i>Switch On</i>
NDVER	S.FLATS.GENW0.69	68.73	38.73	N/A

The reschedule scheme also relieves overload OVL # 7 and 8

7.10.1.3 BC-KELLEY - BC-EARTH 115kV ftlo CASTRO CNTY3 - NEWHART 115kV

The reschedule scheme is to hold DVER wind farm, BETHEL_WND1134.5 to 270 MW.

<i>Type</i>	<i>Generator</i>	<i>Old</i>	<i>New</i>	<i>Switch On</i>
DVER	BETHEL_WND1134.5	294.02	270.00	N/A

7.10.1.4 BRADLEY2 - RUSHSPG4 138kV ftlo NAPLESTP - PAYNE 138 kV

The reschedule scheme in the following table:

<i>Type</i>	<i>Generator</i>	<i>Old</i>	<i>New</i>	<i>Switch On</i>
Thermal	GENCO1 4 13.8	45.88	30	N/A
Thermal	GENCO2 4 13.8	50	10	N/A

The reschedule scheme also relieves overload OVL # 10

7.10.1.5 SMOKYHL - SUMMIT 230kV ftlo POSTROCK7 - AXTELL 345kV

The reschedule scheme in the following table:

<i>Type</i>	<i>Generator</i>	<i>Old</i>	<i>New</i>	<i>Switch On</i>
-------------	------------------	------------	------------	------------------

NDVER	SMKYP1G1	0.69	92.62	82.62	N/A
NDVER	SMKYP2G1	0.69	136.45	126.45	N/A

7.10.1.6 NEOSHO – RIV4525 161kV ftlo 7BLACKBERRY - NEOSHO 345KV

The reschedule scheme in the following table:

<i>Type</i>	<i>Generator</i>	<i>Old</i>	<i>New</i>	<i>Switch On</i>
Thermal	R13G167 13.8	28.11	100.00	N/A

7.10.2 Overload Issues During Transfer

7.10.2.1 SWEETWT - CHISHOLM 230kV ftlo O.K.U. - L.E.S. 345kV

The reschedule scheme in the following table:

<i>Type</i>	<i>Generator</i>	<i>Old</i>	<i>New</i>	<i>Switch On</i>
DVER	ROARK1 34.5	90.96	74.00	N/A
Thermal	HARRNGTON1 124.0	163.00	80.00	N/A
Thermal	HARRNGTON2 124.0	163.00	80.00	N/A
Thermal	HARRNGTON3 124.0	163.00	100.00	N/A

7.10.2.2 PLANT X- SUNDOWN 230kV ftlo TOLK WEST - YOAKUM 230kV

The reschedule scheme is in the following table.

<i>Type</i>	<i>Generator</i>	<i>Old</i>	<i>New</i>	<i>Switch On</i>
Thermal	TOLK_1 124.0	207.31	335.00	N/A
Thermal	TOLK_2 124.0	196.35	335.02	N/A

7.10.2.3 LG-CLAUENE - TERRY CNTY 115kV ftlo SUNDOWN - AMOCO SS 230kV

The reschedule scheme in the following table:

<i>Type</i>	<i>Generator</i>	<i>Old</i>	<i>New</i>	<i>Switch On</i>
Thermal	MUSTANG_1 113.8	0	100.00	Yes
Thermal	MUSTANG_3 122.0	0	100.00	Yes
Thermal	MUSTANG_8S 34.5	0	30.00	Yes

7.10.3 Voltage Violations

After re-dispatch for relieving overloads, voltage violations were found in the base case for certain contingencies. The tables below show under voltage and over voltage violations. Note only the top 55 over-voltages are shown in this report.

Bus Name	Area Name	Pre-ctg V(p.u.)	V (p.u.)	Criteria	Contingency	Notes
LE-TEXACO 3115.	SPS	1.001	0.629	0.9	CUNNINGHAM 3115. - BUCKEYE_TP 3115.	
BUCKEYE 3115.	SPS	1.0041	0.630	0.9		
BUCKEYE_TP 3115.	SPS	1.0042	0.630	0.9		
LE-TXACO_TP3115.	SPS	1.0014	0.630	0.9		
LE-SANANDRS3115.	SPS	0.9996	0.631	0.9		
LE-TEXACO 3115.	SPS	1.001	0.701	0.9	BUCKEYE_TP 3115. - LE-TXACO_TP3115.	
LE-TXACO_TP3115.	SPS	1.0014	0.702	0.9		
LE-SANANDRS3115.	SPS	0.9996	0.703	0.9		
LE-SANANDRS3115.	SPS	0.9996	0.829	0.9	LE-SANANDRS3115. - LE-TXACO_TP3115.	
DUNNING7-CP7115.	WAPA	1.0185	0.841	0.9	MALLARD7 115. - RUTHVILL-CP7115.	
HARAM -CP7115.	WAPA	1.02	0.872	0.9		
WSTBOTJC-CP7115.	WAPA	1.0204	0.872	0.9		
BOTTNO 7 115.	WAPA	1.02	0.882	0.9		
BOTNO_SE-CP7115.	WAPA	1.0204	0.882	0.9		

Table 0.2: Under Voltage Violations

Bus Name	Area Name	Pre-ctg V(p.u.)	V (p.u.)	Criteria	Contingency	Notes
SLEEPING 138.	WFEC	1.0484	1.168	1.05	IODINE 4 138. - MOORLND4 138.	
SLEEPING 138.	WFEC	1.0484	1.166	1.05	FTSUPPLY4 138. - IODINE 4 138.	
FTSUPPLY4 138.	WFEC	1.043	1.162	1.05	IODINE 4 138. - MOORLND4 138.	
IODINE 4 138.	WFEC	1.029	1.162	1.05	IODINE 4 138. - MOORLND4 138.	
FTSUPPLY4 138.	WFEC	1.043	1.160	1.05	FTSUPPLY4 138. - IODINE 4 138.	
HOLLIS 4 138.	AEPW	1.0113	1.145	1.05	CHILD4WT 138. - HOLTP4WT 138.	
HOLTP4WT 138.	AEPW	1.0109	1.144	1.05	CHILD4WT 138. - HOLTP4WT 138.	
WELL 4WT 138.	AEPW	1.0143	1.143	1.05	CHILD4WT 138. - HOLTP4WT 138.	
SHAM 4WT 138.	AEPW	1.0205	1.138	1.05	CHILD4WT 138. - HOLTP4WT 138.	
PARAGLD5 161.	SWPA	0.9873	1.121	1.05	PARAGLD5 161. - CENTR H5 161.	
WELL 4WT 138.	AEPW	1.0143	1.117	1.05	HOLTP4WT 138. - WELL 4WT 138.	
SHAM 4WT 138.	AEPW	1.0205	1.116	1.05	HOLTP4WT 138. - WELL 4WT 138.	
PARAGLD5 161.	SWPA	0.9873	1.105	1.05	CENTR H5 161. - JONESBO5 161.	
CENTR H5 161.	SWPA	0.9858	1.104	1.05	CENTR H5 161. - JONESBO5 161.	
SHAM 4WT 138.	AEPW	1.0205	1.102	1.05	WELL 4WT 138. - SHAM 4WT 138.	
DENVTAP4 138.	AEPW	1.0189	1.098	1.05	T.NO.--4 138. - 46ST--E4 138.	
DENVR-E4 138.	AEPW	1.0197	1.098	1.05	T.NO.--4 138. - 46ST--E4 138.	
W.ED.-E4 138.	AEPW	1.0189	1.098	1.05	T.NO.--4 138. - 46ST--E4 138.	
46ST--E4 138.	AEPW	1.0176	1.098	1.05	T.NO.--4 138. - 46ST--E4 138.	

DENVTAP4 138.	AEPW	1.0189	1.098	1.05	DENVTAP4 138. - 46ST--E4 138.	
DENVR-E4 138.	AEPW	1.0197	1.098	1.05	DENVTAP4 138. - 46ST--E4 138.	
W.ED.-E4 138.	AEPW	1.0189	1.098	1.05	DENVTAP4 138. - 46ST--E4 138.	
ENOGEXT4 138.	AEPW	1.0315	1.089	1.05	LEQUIRE4 138. - ENOGEXT4 138.	
ENOGEX 4 138.	AEPW	1.0314	1.089	1.05	LEQUIRE4 138. - ENOGEXT4 138.	
ROAKTAP4 138.	AEPW	1.0325	1.089	1.05	LEQUIRE4 138. - ENOGEXT4 138.	
REDOK-4 138.	AEPW	1.0332	1.089	1.05	LEQUIRE4 138. - ENOGEXT4 138.	
ROAKPMP4 138.	AEPW	1.0324	1.089	1.05	LEQUIRE4 138. - ENOGEXT4 138.	
GORDON 7 115.	NPPD	1.0535	1.088	1.05	GORDON 7 115. - RUSHVIL7 115.	
DENVR-E4 138.	AEPW	1.0197	1.088	1.05	DENVR-E4 138. - DENVTAP4 138.	
REDOK-4 138.	AEPW	1.0332	1.087	1.05	EUFULA4 138. - STIGLRT4 138.	
ROAKTAP4 138.	AEPW	1.0325	1.087	1.05	EUFULA4 138. - STIGLRT4 138.	
ROAKPMP4 138.	AEPW	1.0324	1.087	1.05	EUFULA4 138. - STIGLRT4 138.	
ENOGEXT4 138.	AEPW	1.0315	1.087	1.05	EUFULA4 138. - STIGLRT4 138.	
ENOGEX 4 138.	AEPW	1.0314	1.087	1.05	EUFULA4 138. - STIGLRT4 138.	
LEQUIRE4 138.	AEPW	1.0315	1.087	1.05	EUFULA4 138. - STIGLRT4 138.	
REDOK-4 138.	AEPW	1.0332	1.087	1.05	REDOK-4 138. - ROAKTAP4 138.	
REDOK-4 138.	AEPW	1.0332	1.086	1.05	LEQUIRE4 138. - STIGLRT4 138.	
STIGLRT4 138.	AEPW	1.0297	1.086	1.05	EUFULA4 138. - STIGLRT4 138.	
STIGLER4 138.	AEPW	1.0295	1.086	1.05	EUFULA4 138. - STIGLRT4 138.	
ROAKTAP4 138.	AEPW	1.0325	1.086	1.05	LEQUIRE4 138. - STIGLRT4 138.	
ENOGEXT4 138.	AEPW	1.0315	1.086	1.05	LEQUIRE4 138. - STIGLRT4 138.	
ENOGEX 4 138.	AEPW	1.0314	1.086	1.05	LEQUIRE4 138. - STIGLRT4 138.	
LEQUIRE4 138.	AEPW	1.0315	1.086	1.05	LEQUIRE4 138. - STIGLRT4 138.	
ROAKPMP4 138.	AEPW	1.0324	1.086	1.05	LEQUIRE4 138. - STIGLRT4 138.	
GORDON 7 115.	NPPD	1.0535	1.085	1.05	CHADRON7 115. - RUSHVIL7 115.	
REDOK-4 138.	AEPW	1.0332	1.084	1.05	ENOGEXT4 138. - ROAKTAP4 138.	
RUSHVIL7 115.	NPPD	1.0505	1.084	1.05	CHADRON7 115. - RUSHVIL7 115.	
ROAKTAP4 138.	AEPW	1.0325	1.084	1.05	ENOGEXT4 138. - ROAKTAP4 138.	
ROAKPMP4 138.	AEPW	1.0324	1.084	1.05	ENOGEXT4 138. - ROAKTAP4 138.	
DENVR-C4 138.	AEPW	1.0364	1.083	1.05	DENVR-C4 138. - KENSH-W4 138.	
DENVR-W4 138.	AEPW	1.0374	1.083	1.05	DENVR-W4 138. - S.S.---4 138.	
KENNETT5 161.	SWPA	1.0017	1.082	1.05	PARAGLD5 161. - CENTR H5 161.	
SHAM 3WT 115.	AEPW	0.9811	1.081	1.05	CHILD4WT 138. - HOLTP4WT 138.	

Table 0.3: Over Voltage Violations

General AEP Note:

Some IDEV files have not been applied to the areas seeing voltage violations.

SEASONAL LOAD POCKET ANALYSIS 2017 AND 2021

8.1 OVERVIEW OF SEASONAL LOAD POCKET ANALYSIS

A Load Pocket Analysis was performed by increasing load within the load pocket while increasing wind transfer to the load area. The transfer was increased while under contingency until voltage collapse occurred on the transmission system. A 5% stability margin was used for the transfer limit to determine reactive reserve requirement at the point of voltage collapse. A total of 8 load pocket area shown below were analyzed.

Load Pockets by area.

Area 1: Eastern Nebraska (Lincoln, Omaha)

Area 2: South Oklahoma

Area 3: SPS – South

Area 4: West Oklahoma (Woodward Area)

Area 5: South Central Westar (Wichita Load Area)

Area 6: Kansas City

Area 7: Oklahoma City

Area 8: Williston

8.2 SIMULATION CASE SETUP

Control settings have set in the analysis for all study cases. In pre-contingency stage:

- Generation – remote voltage control enabled
- Transformers – taps enabled
- Phase shifting transformers – enabled
- Discrete switched Shunts – enabled
- SVC and continuous switched shunt – enabled
- Line Shunts – fixed
- HVDC – fixed schedule
- SPS action - disabled

In post-contingency stage:

- Generation – AVR local voltage control
- Transformers – taps locked
- Phase shifting transformers – locked
- Discrete switched Shunts – locked
- SVC and continuous switched shunt – enabled
- Line Shunts – fixed
- HVDC – fixed schedule
- SPS action - enabled

Stability criteria are set to check branch flows and monitor voltage limits in SPP footprint. Only voltage level above 100kV components are checked or monitored. The branch flows check settings are:

Pre-contingency – Line Rating: 1; Transformer Rating: 1; Flow Check Threshold: 100%

Post-contingency – Line Rating: 2; Transformer Rating: 2; Flow Check Threshold: 100%

The voltage limits monitoring settings are:

Pre-contingency – Low Limit: 0.95pu; High Limit: 1.05pu.

Post-contingency – Low Limit: 0.90pu; High Limit: 1.05pu.

Contingency list is generated by T-1 for all branches above 100kV in SPP footprint.

Contingencies on zero-impedance branches are not valid. For instance contingencies on NEOSHO 161kV were not included in the study.

8.3 BASE CASE CLEANUP

A few data errors have been identified prior the analysis. During the analysis, some minor data changes are made to improve better powerflow convergence and prevent solution hunting.

Data errors are:

Reactance on line CANDOJCT-CP869.0 - CANDOTP2-CP869.0 was 192142pu and changed to the correct value: 0.192142pu

Line ratings on FLETCHR2 - MARLOWJ2 138kV is corrected to 103MW/160MW

Line ratings on BC-EARTH - PLANT_X 115kV is corrected to 120MW/154MW

Power output from wind farms SLICKHILLS and BLUCAN exceed generators' maximum limit and also exceed the feeder thermal limit. The changes were curtailing power output of those wind farms to be within the limit.

Equivalence low voltage radial lines to improve voltage stability:

Voltage stability issue occurs in SPS-LEA area, i.e., low voltage (69kV) buses near HOBBS, Maddox, Buckeye, San Andres area. Instability occurs at contingency: O.K.U. – L.E.S. 345kV and TATONGA – MATHWSN 345kV;

To improve better powerflow convergence, the following minor powerflow changes are made:

Tertiary out at three winding transformers:

MCNOWND7 345.
PALDR2W7 345.
BUFLOCRK6 230.

Minor impedance change at three winding transformers:

N-DODGE3	115.	-	Primary Reactance; -0.696591 pu
SUNDOWN	6230.	-	Tertiary Reactance; 0.062835 pu
MCNOWND7	345.	-	Secondary Reactance; 0.0530078 pu
CRSRDW11	34.5	-	Secondary Reactance; 0.00998 pu
CRSRDW21	34.5	-	Secondary Reactance; 0.0107786 pu
MAMTHPW7	345.	-	Secondary Reactance; 0.0107786 pu

Phase shift correction at adjustable transformers:

PRWNDCL1 34.5
SHP234 1 34.5

8.4 BASE CASE OVERLOADS

Overloads were present in the base case. Overloads, sorted by most severe contingencies at the top, for both pre and post contingency results are detailed in Table 8.4.1 and Table 8.4.2. The most significant overload was 164%, caused by the Tatonga to Mathewson contingency. The base case was re-dispatched to mitigate severe overloads and discussed the next section.

OVL #	Overloaded Branch	Area Name	MVA Rating	OVL %	Contingency
1	WASHITA4 138. - SLICKHILLS4 138	WFEC	246.00	103.3	Pre-contg.
2	WOODWRD4 138. - WINDFRM4 138	OKGE	133.00	100.9	

Table 8.4.1: Pre-Contingency Overloads

OVL #	Overloaded Branch	Area Name	MVA Rating	OVL %	Contingency
1	WOODWRD4 138. - WINDFRM4 138	OKGE	153.00	164.3	TATONGA7 345. - MATHWSN7 345.
2	WINDFRM4 138. - MOORLND4 138	OKGE-WFEC	287.00	110.5	
3	WEBBTAP4 138. - OSAGE 4 138	AEPW-OKGE	191.00	121.0	CLEVLND7 345. - SOONER 7 345.
4	SUNDOWN 6230. - AMOCO_SS 6230	SPS	318.69	119.5	TOLK_WEST 6230. - YOAKUM 6230.
5	PLANT_X 6230. - SUNDOWN 6230	SPS	318.69	115	
6	WOODWRD4 138. - WINDFRM4 138	OKGE	153.00	116.3	WWRDEHV7 345. - TATONGA7 345.
7				114.6	ELKCITY6 230. - SWEETWT6 230.
8	OCHOA 3115. - WHITTEN 3115	SPS	141.22	111.5	POTASH_JCT 6230. - RDRUNNER 6230.
9	SUNDOWN 6230. - AMOCO_SS 6230	SPS	318.69	111.1	CROSSROADS 7345. - EDDY_CNTY 7345.
10	PLANT_X 6230. - SUNDOWN 6230	SPS	318.69	109.2	
11	WOODWRD4 138. - WINDFRM4 138	OKGE	153.00	110.3	
12	HUTCH_S 3115. - MARTIN 3115	SPS	119.51	109.3	HIGHLAND_TP3115. - PANTEX_S 3115.
13				108.9	MARTIN 3115. - PANTEX_N 3115.
14	WOLFFORTH 3115. - TERRY_CNTY 3115	SPS	119.51	108.7	SUNDOWN 6230. - AMOCO_SS 6230.
15	LG-CLAUENE 3115. - TERRY_CNTY 3115	SPS	79.67	105.8	
16	TOLK_WEST 6230. - YOAKUM 6230	SPS	318.69	103.8	
17	HUTCH_S 3115. - MARTIN 3115	SPS	119.51	108.3	PANTEX_N 3115. - PANTEX_S 3115.
18	WOODWRD4 138. - WINDFRM4 138	OKGE	153.00	108.1	WINDFRM4 138. - FPLWIND4 138.
19	LE-WEST_SUB3115. - LE-NRTH_INT3115	SPS	131.46	104.6	CUNNINGHAM 3115. - BUCKEYE_TP 3115.

20	TUPELO 4 138. - TUPLOT4 138	SWPA-WFEC	143.00	103.2	SUNNYS7 345. - HUGO 7 345.
21	WOODWRD4 138. - WINDFRM4 138	OKGE	153.00	102.7	FTSUPLY4 138. - SLEEPING 138.
22				102.6	IODINE-4 138. - WWRDEHV4 138.
23	BUTLER 4 138. - ALTOONA4 138	WERE	96.00	102.2	CANEYRV7 345. - NEOSHO 7 345.
24	PLANT_X 3115. - LAMB_CNTY 3115	SPS	79.67	101.7	TOLK_WEST 6230. - LAMB_CNTY 6230.
25	LE-WEST_SUB3115. - LE-NRTH_INT3115	SPS	131.46	101.4	BUCKEYE_TP 3115. - LE-TXACO_TP3115.
26	WOODWRD4 138. - WINDFRM4 138	OKGE	153.00	100.7	DEWEY 4 138. - IODINE-4 138.
27	PLANT_X 6230. - SUNDOWN 6230	SPS	318.69	100.7	TUCO_INT 6230. - JONES 6230.
28				100.3	LUBBCK_STH 6230. - WOLFFORTH 6230.

Table 8.4.2: Post-Contingency Overloads

8.5 BASECASE RE-DISPATCH

The most severe overloads caused by contingencies are numbered (OVL #) in Table 8.4.2. This section suggests re-dispatch patterns to mitigate severe overloads.

For the scope of this study, the procedure is to re-dispatch in the following order: 1st thermal units (except Nuclear), 2nd DVERS (dispatchable variable energy resources), 3rd NDVERS (Non-dispatchable Variable Energy Resources) to remedy the violation. However, most overloads were very local to their area. In some cases NDVERS were dispatched, however their wind MW change was picked up by other wind units in SPP. Typically generators were often chosen due to their proximity to overloaded branches.

After mitigating severe overloads, further re-balancing dispatch for the purposes of maintaining wind penetration was performed. Some additional units were also turned on for voltage stability issues after re-balancing.

8.5.1 BASECASE CONSTRAINT RE-DISPATCH ACTIONS

8.5.1.1 WOODWRD4 138kV. - WINDFRM4 138kV ftlo TATONGA7 345kV. - MATHWSN7 345kV.

This overload was relieved to under 110% by performing the following re-dispatch shown below:

Type	Generator	Old	New	Switch On
Thermal	MORLND4 18.0	0	300	Yes
NDVER	CENT 21 34.5	62.51	10	N/A
NDVER	OUSPRT 1 34.5	79.12	10	N/A

These actions relieved post-contingency overloads for OVL # 1, 2, 6, 7, 11 below 110% overload

8.5.1.2 WEBBTAP4 138kV. - OSAGE 4 138kV ftlo CLEVLND7 345kV. - SOONER 7 345kV.

This overload was relieved to under 110% by performing the following re-dispatch shown below:

Type	Generator	Old	New	Switch On
Thermal	SOONER1G 22.0	477.36	75	N/A
NDVER	KEENAN 1 34.5	118.36	100	N/A
NDVER	FPLWND11 34.5	80.27	50	N/A

These actions relieved post-contingency overloads for OVL # 3 below 110% overload

8.5.1.3 SUNDOWN 6 230kV - AMOCO SS 6 230kV ftlo TOLK WEST 6 230kV - YOAKUM 6 230kV.

This overload was relieved to under 110% by performing the following re-dispatch shown below:

Type	Generator	Old	New	Switch On
Thermal	TOLK_2 124.0	535	350	N/A
Thermal	TOLK_1 124.0	384.5	350	N/A
Thermal	MUSTANG_3 122.0	0	100	Yes
Thermal	MUSTANG_1 113.8	0	100	Yes

These actions relieved post-contingency overloads for OVL # 4, 5 below 110% overload

8.5.1.4 OCHOA 115kV. - WHITTEN 115kV ftlo POTASH JCT6 230. - RDRUNNER6 230kV.

This contingency creates several radial lines with loads at the end. Ochoa – Whitten is one of those radial lines that gets overloaded. Due to this topology, it is not possible to relieve the overload by dispatch (see Figure 8.5.1)

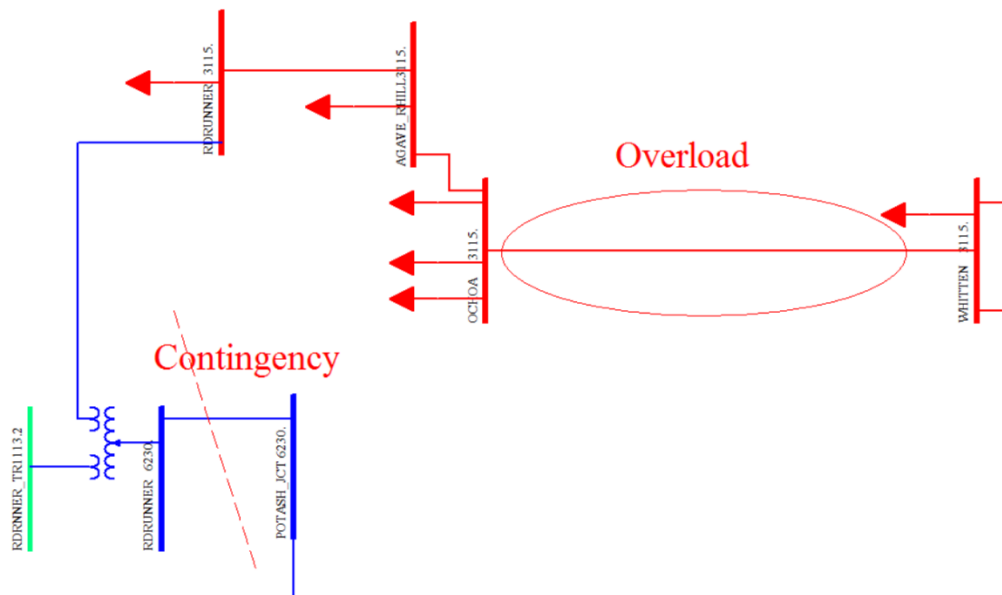

Figure 8.5.1: Radial Loads after Contingency

8.5.1.5 HUTCH S 115kV. - MARTIN 115kV ftlo HIGHLAND TP 115kV. - PANTEX S 115kV.

This overload was relieved to under 110% by performing the following re-dispatch shown below:

<i>Type</i>	<i>Generator</i>	<i>Old</i>	<i>New</i>	<i>Switch On</i>
NDVER	MAJSTC-WTG110.69	61.16	50	N/A

This action relieved post-contingency overload for OVL # 8 below 110% overload

8.5.2 DISPATCH BALANCING FOR MAINTAINING WIND PENETRATION

Once severe overloads (over 110%) has been relieved, total thermal generation has decreased by 122MW and total wind has decreased by 355MW. The loss of thermal MW and wind MW where balanced separately.

The 122MW thermal deficit was evenly picked up by thermal generators used the in “sink” of the transfer definition of the system stability study done in the previous chapter.

The 355MW wind deficit was evenly picked up by the wind units in the “source” of the transfer definition used in both the system stability and load pocket study.

Dispatch balancing was performed in VSAT by creating a special case that would apply a thermal generation re-dispatch and a separate wind generation re-dispatch. Separate thermal and wind governor files where used to pick-up the missing generation, instead of using the swing bus.

8.5.3 DISPATCH FOR VOLTAGE STABILITY ISSUES AFTER BALANCING

After balancing to maintain wind penetration, contingencies “TATONGA7 345kV. - MATHWSN7 345kV.” and “O.K.U.-7 345kV. to L.E.S.-7 345kV.” were found to be voltage unstable at the base.

To obtain an idea of where the system is collapsing for those contingencies, modal analysis was performed. Since those contingencies cause the powerflow to diverge, the base case pre-contingency was taken, then the impedance of the “TATONGA7 345kV. - MATHWSN7 345kV.” line was increased simulate a partial outage while still enabling the powerflow to solve. Modal analysis was performed on this powerflow. The participation factors are plotted in Figure 8.5.2 which indicates a collapse in the south Oklahoma region.

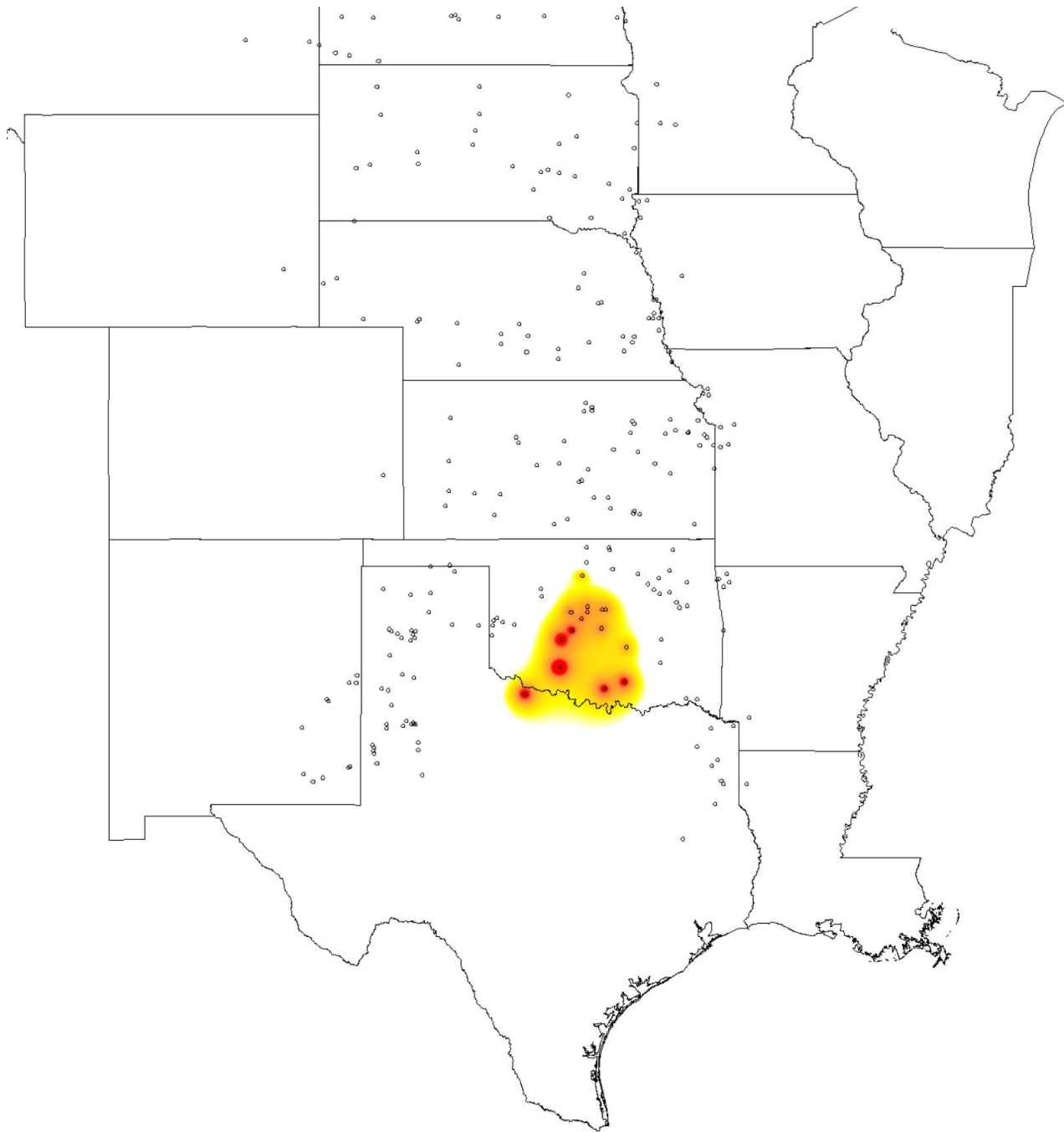

Figure 8.5.2: Modal Analysis Participation Factor Contour

To resolve voltage collapse for these two contingencies, the following re-dispatch shown below was used.

Type	Generator	Old	New	Switch On
Thermal	REDBUD4S 18.0	0	36	Yes
Thermal	MCLN 2G 18.0	0	42	Yes

These thermal units were selected due to their location in the Oklahoma region. These units did not have Pmin greater than zero, so they were set to 25% of Pmax. There are a total of eight REDBUD units, this re-dispatch is only activating one unit, and the other seven remain out-of-service. Similarly there are three MCLN units, this re-dispatch is only activating one unit, and the other two units remain out-of-service.

These units were turned on for their MVAR capacity to help with voltage support. The REDBUD unit has an output of 70MVAR and the MCLN unit has 58MVAR.

Then re-balanced, using the same procedure documented in the previous subsection, was used to maintain wind penetration. VSAT was then used to solve the base case for all contingencies. The base case was found to be voltage stable for all contingencies.

8.6 VOLTAGE VIOLATIONS

After re-dispatch for relieving overloads, voltage violations were found in the base case for certain contingencies. The tables below show under voltage and over voltage violations. Note only the top 45 over-voltages are shown in this report.

Bus Name	Area Name	Pre-ctg V (p.u.)	V (p.u.)	Criteria	Contingency	Notes
LE-TEXACO 3115.	SPS	1.001	0.7568	0.9	CUNNINGHAM 3115. - BUCKEYE_TP 3115.	
BUCKEYE 3115.	SPS	1.0041	0.7569	0.9		
BUCKEYE_TP 3115.	SPS	1.0042	0.7571	0.9		
LE-TXACO_TP3115.	SPS	1.0014	0.7573	0.9		
LE-SANANDRS3115.	SPS	0.9996	0.7581	0.9		
LE-TEXACO 3115.	SPS	1.001	0.7885	0.9	BUCKEYE_TP 3115. - LE-TXACO_TP3115.	
LE-TXACO_TP3115.	SPS	1.0014	0.789	0.9		
LE-SANANDRS3115.	SPS	0.9996	0.7896	0.9		
NEVADA 5 161.	GMO	1.0052	0.8284	0.9	5BUTLER 161. - NEVADA 5 161.	
TIOGA 4 138.	WERE	0.9492	0.8293	0.9	TIOGA 4 138. - ALTOONA4 138.	
COWSKIN 138.	GRDA	0.9982	0.8391	0.9	GROVE 4 138. - COWSKIN 138.	1
LE-SANANDRS3115.	SPS	0.9996	0.8588	0.9	LE-SANANDRS3115. - LE-TXACO_TP3115.	
BEARCREK-MK7115.	WAPA	1.011	0.8645	0.9	BEARCREK-MK7115. - ROUNDUP 7115.	2
OAKDALE -MK7115.	WAPA	1.0073	0.8667	0.9		2
KILLDEER-MK7115.	WAPA	1.0081	0.879	0.9	BEARCREK-MK7115. - ROUNDUP 7115.	2
KILDEER7 115.	WAPA	1.0082	0.8802	0.9		2
RBNSNLAK-MW7115.	WAPA	1.0261	0.8855	0.9	BELDEN -MW7115. - RBNSNLAK-MW7115.	3
FINSTAD -MW7115.	WAPA	1.0229	0.8882	0.9		3
OSBORN -MW7115.	WAPA	1.0198	0.8905	0.9		3
BIGBEND -MW7115.	WAPA	1.0188	0.8909	0.9		3
ENEWTWN - MW7115.	WAPA	1.0192	0.8913	0.9		3
ROMNOSE4 138.	OKGE	0.9792	0.8937	0.9	TATONGA7 345. - MATHWSN7 345.	

VANHOOK -MW7115.	WAPA	1.0151	0.8937	0.9	BELDEN -MW7115. - RBNSNLAK-MW7115.	3
CLEOCOR4 138.	OKGE	0.9739	0.8948	0.9	TATONGA7 345. - MATHWSN7 345.	
CLEOPLT4 138.	OKGE	0.9739	0.8948	0.9		
CLEO PL4 138.	OKGE	0.9741	0.895	0.9		
PARSHALL-MW7115.	WAPA	1.012	0.8974	0.9	BELDEN -MW7115. - RBNSNLAK-MW7115.	3
TIOGA 4 138.	WERE	0.9492	0.9492	0.95	Pre Contingency	

Table 8.6.1: Under Voltage Violations

Itemized Notes from Under Voltage Table:

1. GRDA has indicated that (a) The load at Whitewater sub. (512743) was incorrectly modelled in the 2017 light load case. That load should be 4.7MW & 1MVar instead of 26MW & 5.3MVar. (b) The Cowskin auto transformer min/max voltage regulation (Vmin/Vmax) should be set at 0.9 and 1.1. The Vmin is currently being set at 1.0338pu in the cases which is too high. (c) No load is being connected to the 138kV side of the auto transformer under post contingent condition, the LTC permits tap changing to regulate the Cowskin 69kV bus to 1.0338pu as indicated in the setting causing the voltage on the 138kV to drop below 0.9. This issue will be fixed in the 2017 MDWG model set.
2. Manual check, voltage OK for N-1. (Appears like results from N-2)
3. Parshall Area UVLS installed

Bus Name	Area Name	Pre-ctg V (p.u.)	V (p.u.)	Criteria	Contingency	Notes
DENVTAP4 138.	AEPW	1.0189	1.1633	1.05	T.NO.--4 138. - 46ST--E4 138.	
46ST--E4 138.	AEPW	1.0176	1.1632	1.05		
DENVR-E4 138.	AEPW	1.0197	1.1632	1.05		
W.ED.-E4 138.	AEPW	1.0189	1.1632	1.05		
DENVR-E4 138.	AEPW	1.0197	1.1606	1.05	DENVTAP4 138. - 46ST--E4 138.	
DENVTAP4 138.	AEPW	1.0189	1.1606	1.05		
W.ED.-E4 138.	AEPW	1.0189	1.1606	1.05		
DENVR-E4 138.	AEPW	1.0197	1.1504	1.05	DENVR-E4 138. - DENVTAP4 138.	
SLEEPING 138.	WFEC	1.0484	1.1413	1.05	IODINE 4 138. - MOORLND4 138.	
DENVR-C4 138.	AEPW	1.0364	1.1412	1.05	DENVR-C4 138. - KENSH-W4 138.	
SLEEPING 138.	WFEC	1.0484	1.1405	1.05	FTSUPPLY4 138. - IODINE 4 138.	
DENVR-W4 138.	AEPW	1.0374	1.1388	1.05	DENVR-W4 138. - S.S.---4 138.	
DENVR-C4 138.	AEPW	1.0364	1.1382	1.05	CARSN-S4 138. - KENSH-W4 138.	
KENSH-W4 138.	AEPW	1.036	1.1382	1.05		
FTSUPPLY4 138.	WFEC	1.043	1.1363	1.05	IODINE 4 138. - MOORLND4 138.	
IODINE 4 138.	WFEC	1.029	1.1358	1.05		
FTSUPPLY4 138.	WFEC	1.043	1.1356	1.05	FTSUPPLY4 138. - IODINE 4 138.	
HOLLIS 4 138.	AEPW	1.0113	1.1211	1.05	CHILD4WT 138. - HOLTP4WT 138.	
HOLTP4WT 138.	AEPW	1.0109	1.1206	1.05		
BOWERS 3115.	SPS	1.0446	1.1203	1.05	BOWERS 3115. - HOWARD 3115.	

WELL 4WT 138.	AEPW	1.0143	1.1192	1.05	CHILD4WT 138. - HOLTP4WT 138.	
SHAM 4WT 138.	AEPW	1.0205	1.115	1.05		
DENVR-C4 138.	AEPW	1.0364	1.1115	1.05	CARSN-S4 138. - T.P.S.-4 138.	
KENSH-W4 138.	AEPW	1.036	1.1113	1.05		
CARSN-S4 138.	AEPW	1.0357	1.1112	1.05		
RATLIFF4 138.	OKGE	1.0094	1.0956	1.05	RATLIFF4 138. - CARTRCO4 138.	1
SHAM 4WT 138.	AEPW	1.0205	1.0945	1.05	CHILD4WT 138. - LAKEP4WT 138.	
WELL 4WT 138.	AEPW	1.0143	1.0942	1.05		
WELL 4WT 138.	AEPW	1.0143	1.094	1.05	HOLTP4WT 138. - WELL 4WT 138.	
HOLLIS 4 138.	AEPW	1.0113	1.0938	1.05	CHILD4WT 138. - LAKEP4WT 138.	
HOLTP4WT 138.	AEPW	1.0109	1.0933	1.05		
SHAM 4WT 138.	AEPW	1.0205	1.0933	1.05	HOLTP4WT 138. - WELL 4WT 138.	
GORDON 7 115.	NPPD	1.0535	1.0926	1.05	GORDON 7 115. - RUSHVIL7 115.	
CHILD4WT 138.	AEPW	1.0047	1.0897	1.05	CHILD4WT 138. - LAKEP4WT 138.	
GORDON 7 115.	NPPD	1.0535	1.0894	1.05		
RUSHVIL7 115.	NPPD	1.0505	1.0886	1.05		
BOWERS 3115.	SPS	1.0446	1.0876	1.05	WHEELER 3115. - HOWARD 3115.	
SPVALLY4 138.	OKGE	1.0521	1.0846	1.05	BRISTOW4 138. - GRNWOOD4 138.	2
KNIPE 4 138.	OKGE	1.052	1.0845	1.05		2
PAYNESB4 138.	OKGE	1.0521	1.0845	1.05		2
CUSHING4 138.	OKGE	1.0515	1.0839	1.05		2

Table 8.6.2: Over Voltage Violations

Itemized Notes from Over Voltage Table:

1. This over-voltage is more outage related. In addition to the contingency, bus PRARPNT4 138 is already outaged in the power flow making this condition worse than N-1. In this case Ratliff 138kV is backedfed by the long 69kV radial line from Healdton 138kV substation. . Given the weak system it is connected to in this configuration, the switching of the CAPs at Ratliff 138kV would create significant voltage deviation.
2. OKGE has indicated turning off Cushing area capacitor banks (SEAWAYS2 69.0 and TIGERCK2 69.0) would relieve these over voltages.

General AEP Note:

Some IDEV files have not been applied to the areas seeing voltage violations.

8.7 TRANSFER SETUP

All transfers will use the re-dispatched base case powerflow. Any wind that was curtailed to relieve overload was also curtailed in the both the governor file and transfer file. This would prevent curtailed wind units from increasing during the transfer. It would also prevent curtailed wind units from picking up MW mismatch after a contingency or during powerflow iterations.

The VSAT transfer was setup with a transfer step size of 50MW with 10MW cut-step. Therefore, the collapse point was generally found to be 10MW after all reported limits in this chapter.

Note, for G-1 outages, if it's a thermal generator outage, then VSAT's governor file will pick up this thermal MW loss with wind, thus advancing the transfer forward by the thermal MW amount.

Q-V analysis was performed at the base point and at 95% point of the transfer. For instance, if the ATC is 100MW then Q-V analysis will be performed at ATC=0MW and at ATC= 95MW.

8.8 AREA1: EASTERN NEBRASKA(LINCOLN, OMAHA)

Initial Load	Study Type	Load Limit	ATC	Critical Contingency
1059	G-1	2239	1180	NEBCTY2G 23.0 (499MW Output)
	T-1	1229	170	TATONGA7 345. - MATHWSN7 345.
	Combined	1059	0	

Table 8.8.1: Area 1 Results

The G-1 critical contingency causes a collapse in the south Oklahoma region (based on modal analysis). This generator is the largest MW output of the G-1 contingencies for this load pocket. The loss of this 499MW generator will be balanced by wind, which stresses south Oklahoma since this region contains a lot of wind farms.

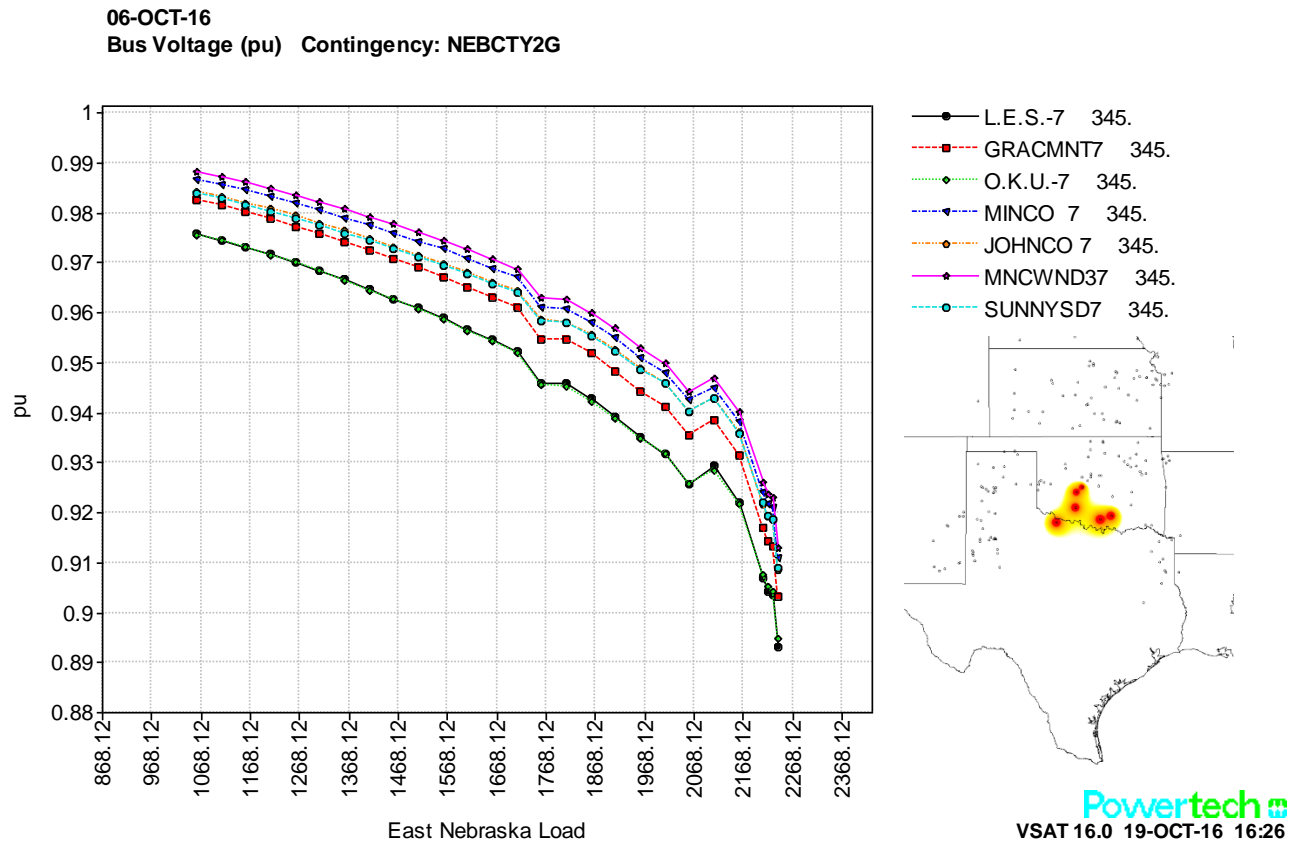

Figure 8.8.1: G-1 P-V Curves

The T-1 contingency *Tatonga to Matthewson* is the limiting contingency for this load pocket as well as most other load pockets. The tripping of this 345kV line significantly weakens the voltage stability of the southern Oklahoma region. Due to this region containing a lot of wind farms, it is

sensitive to increases in SPP wind. Since all load pockets increase wind to match load increase, each load pocket's transfer will naturally cause particular stress the south Oklahoma region.

Modal analysis results for the *Tatonga to Matthewson* was performed and indicated collapse in the south Oklahoma region. This can also be visualized in Figure 8.8.2, where the modal analysis participation factors are plotted on the SPP footprint.

The T-1 P-V curve for the critical contingency is shown in Figure 8.8.3.

The combined G-1 and T-1 study indicates that the severity of this combined contingency causes a collapse at the base point.

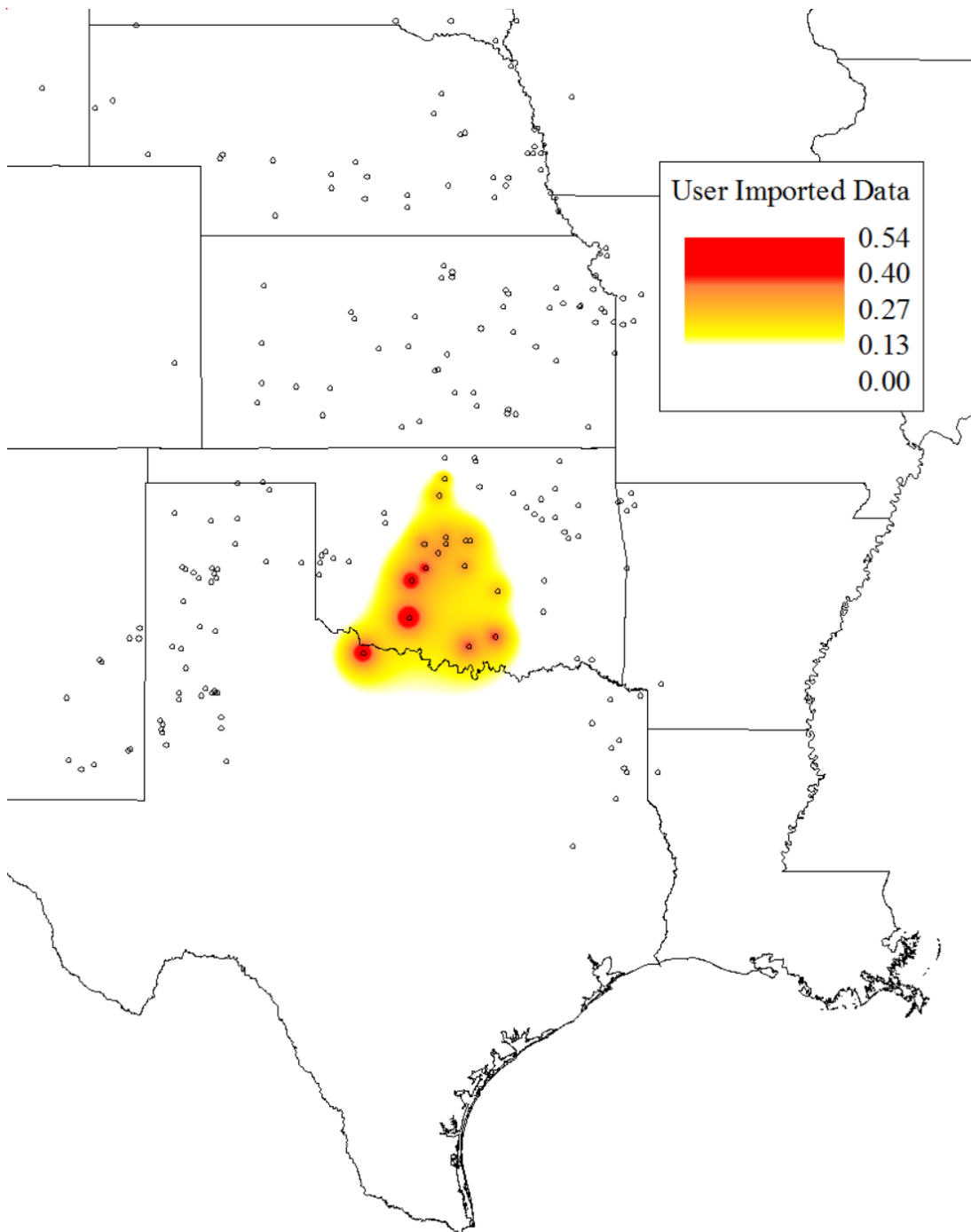

Figure 8.8.2: T-1 Modal Analysis Participation Factor Contour

06-OCT-16
Bus Voltage (pu) Contingency: tatonga-matthewson

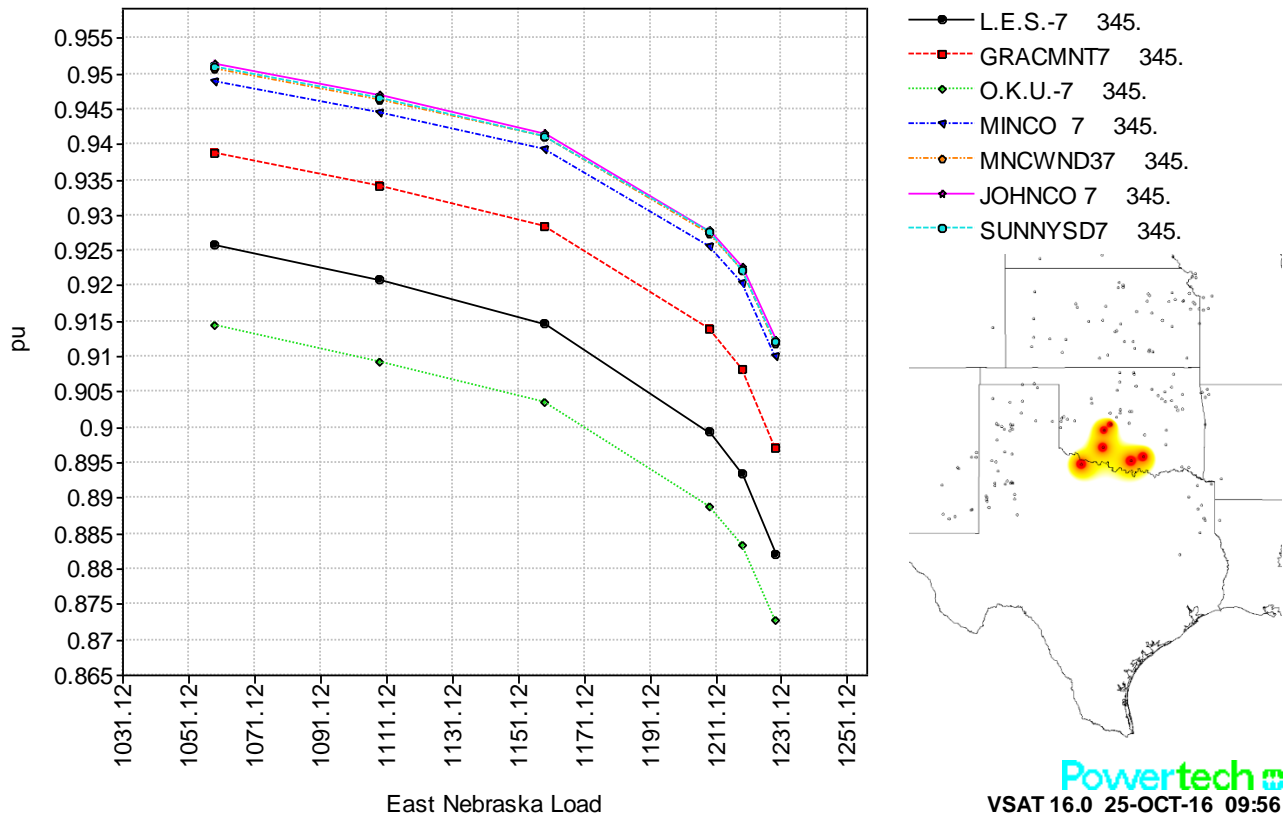

Figure 8.8.3: T-1 P-V Curves

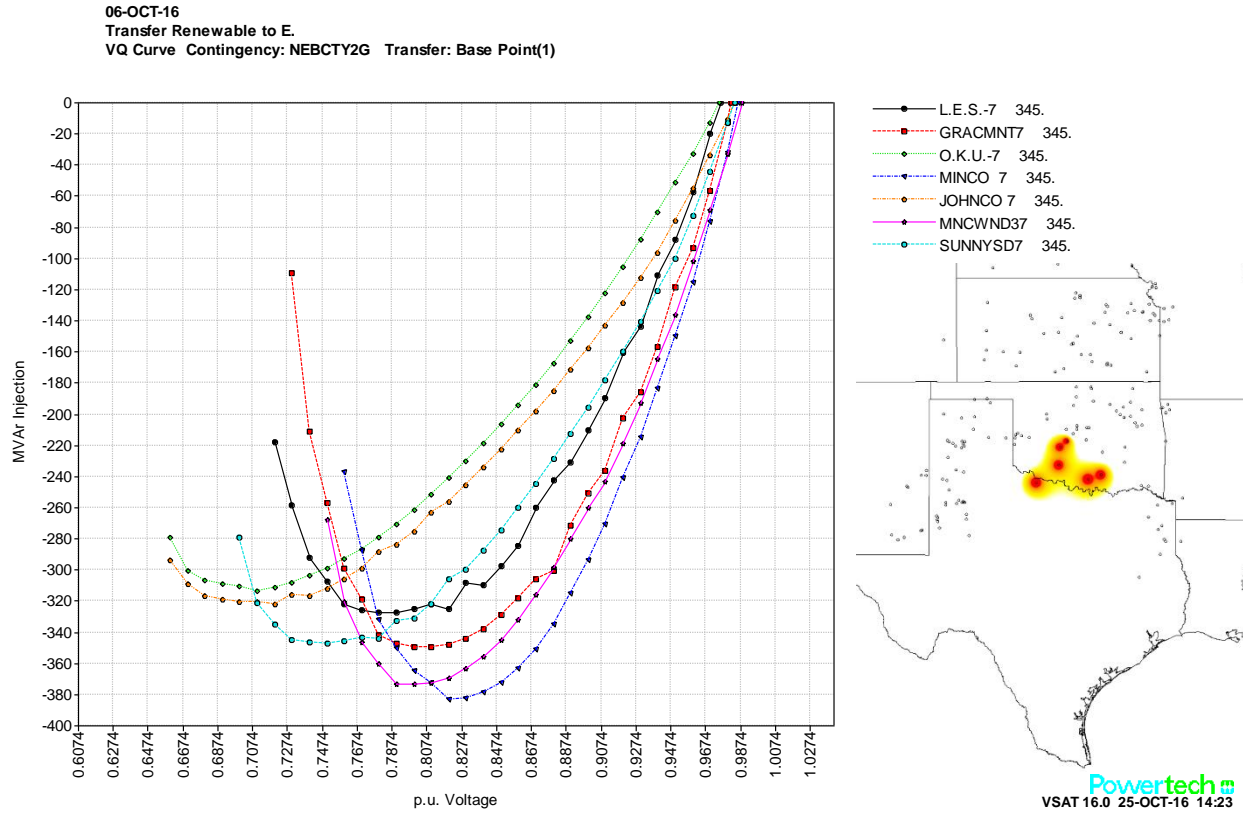

Figure 8.8.4: G-1 Q-V Curves – Base Point

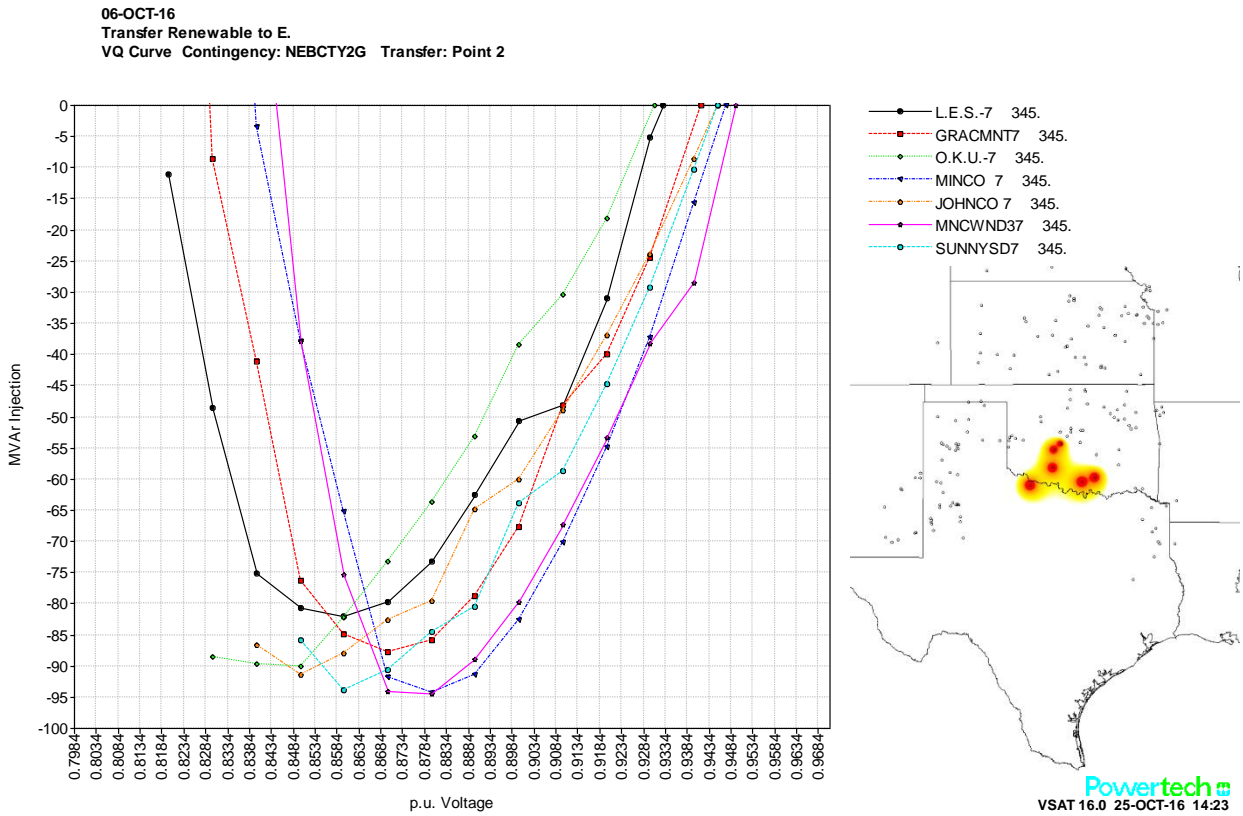

Figure 8.8.5: G-1 Q-V Curves – 95% Point (ATC=1121MW)

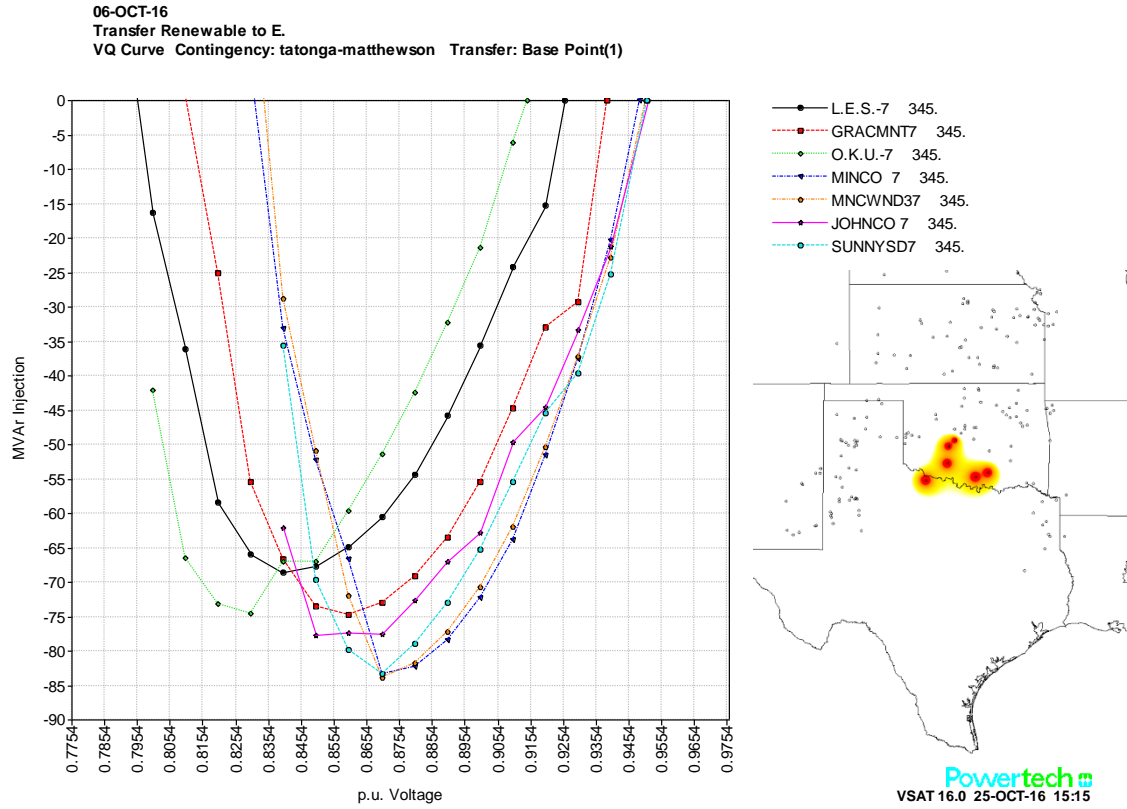

Figure 8.8.6: T-1 Q-V Curves – Base Point

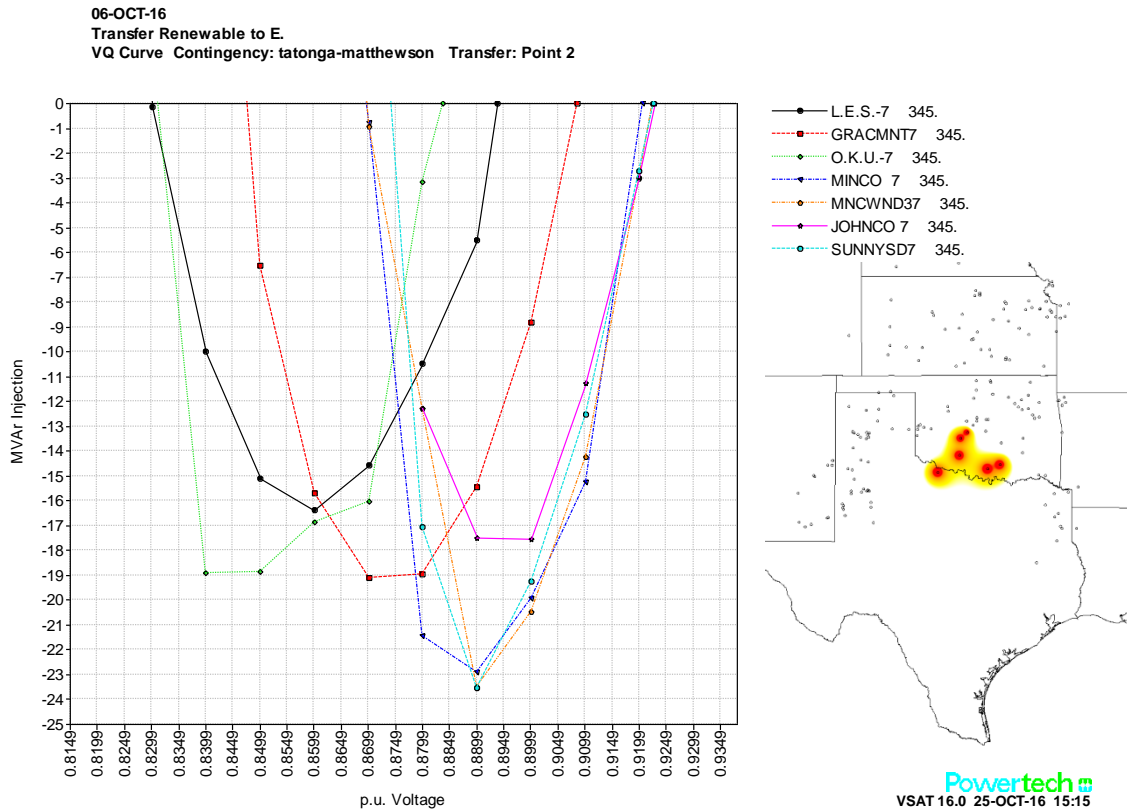

Figure 8.8.7: T-1 Q-V Curves – 95% Point (ATC=161.5MW)

8.9 AREA2: SOUTH OKLAHOMA

Initial Load	Study Type	Load Limit	ATC	Critical Contingency
244	G-1	754	510	ARBWND11 34.5 (80MW)
	T-1	284	40	TATONGA7 345. - MATHWSN7 345.
	Combined	244	0	

Table 8.9.1: Area 2 Results

The G-1 limiting contingency is a wind unit which causes a collapse in south Oklahoma.

The T-1 limiting contingency is similar to other load pockets. As described in area 1, the collapse is south Oklahoma. Since this load pocket is also increasing load in south Oklahoma, it has the smallest T-1 transfer compare to all other load pockets.

The combined G-1 and T-1 study indicates that the severity of this combined contingency causes a collapse at the base point.

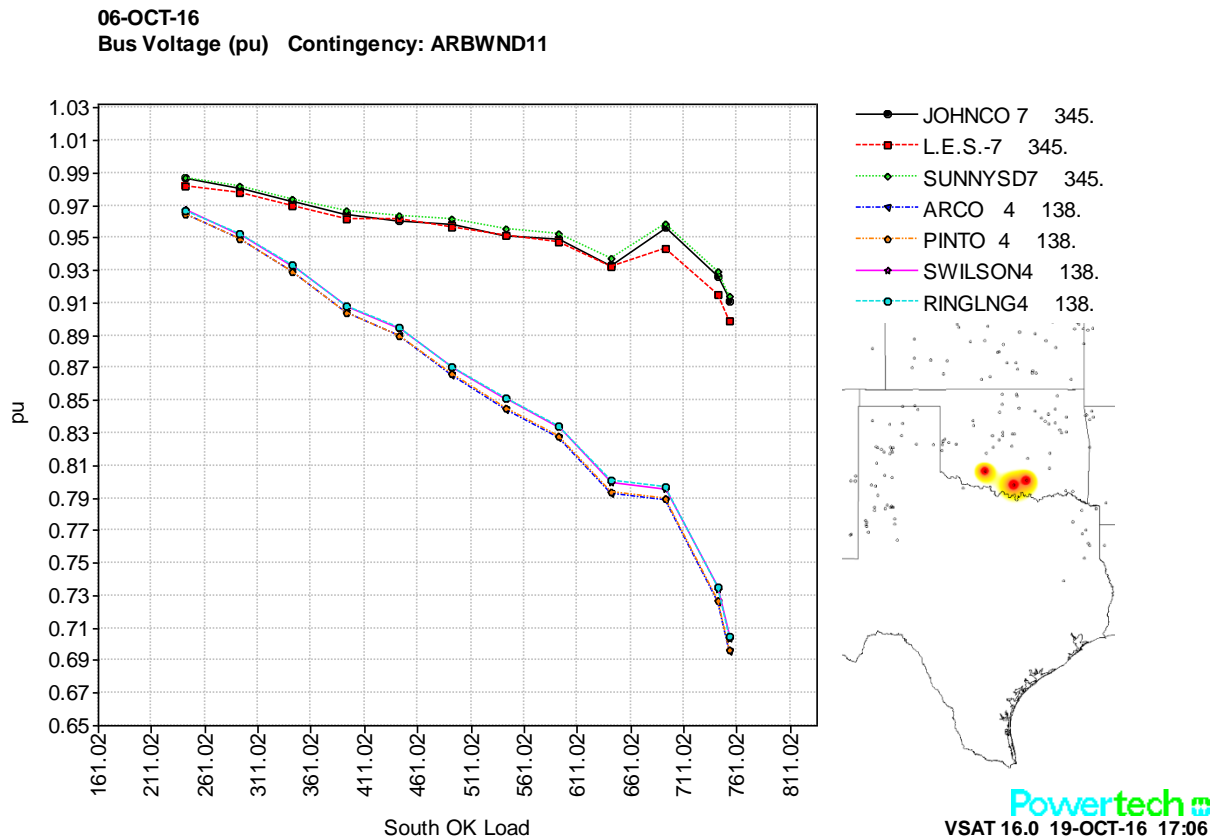

Figure 8.9.1: G-1 P-V Curves

06-OCT-16
 Bus Voltage (pu) Contingency: tatonga-matthewson Scenario: Area 2 - SouthOK

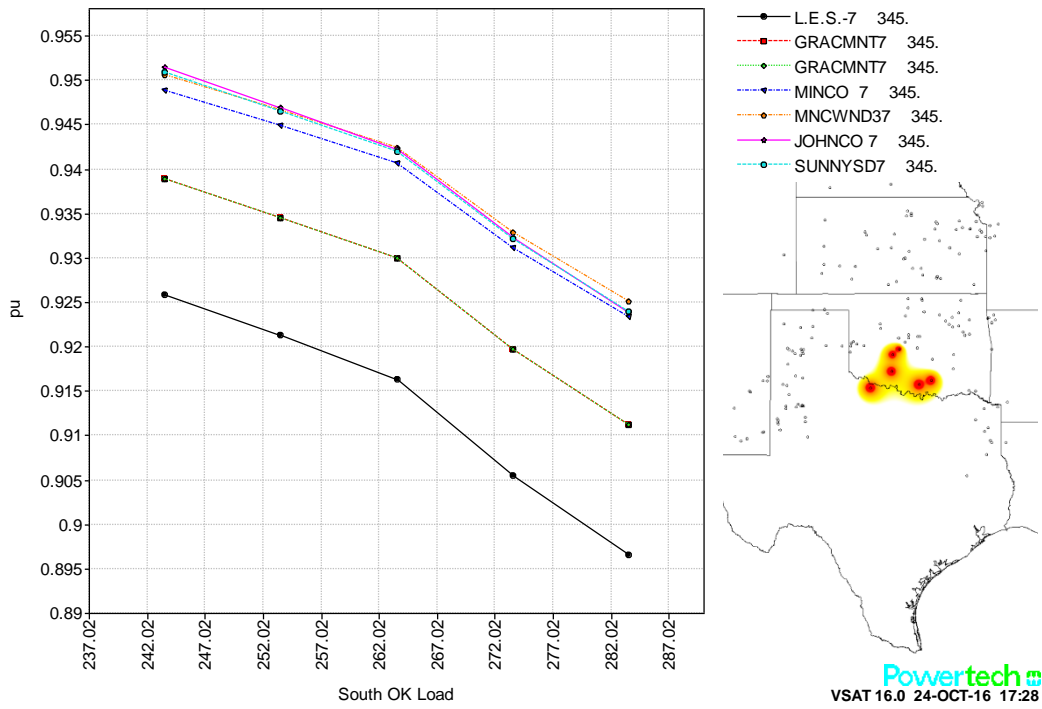

Figure 8.9.2: T-1 P-V Curves

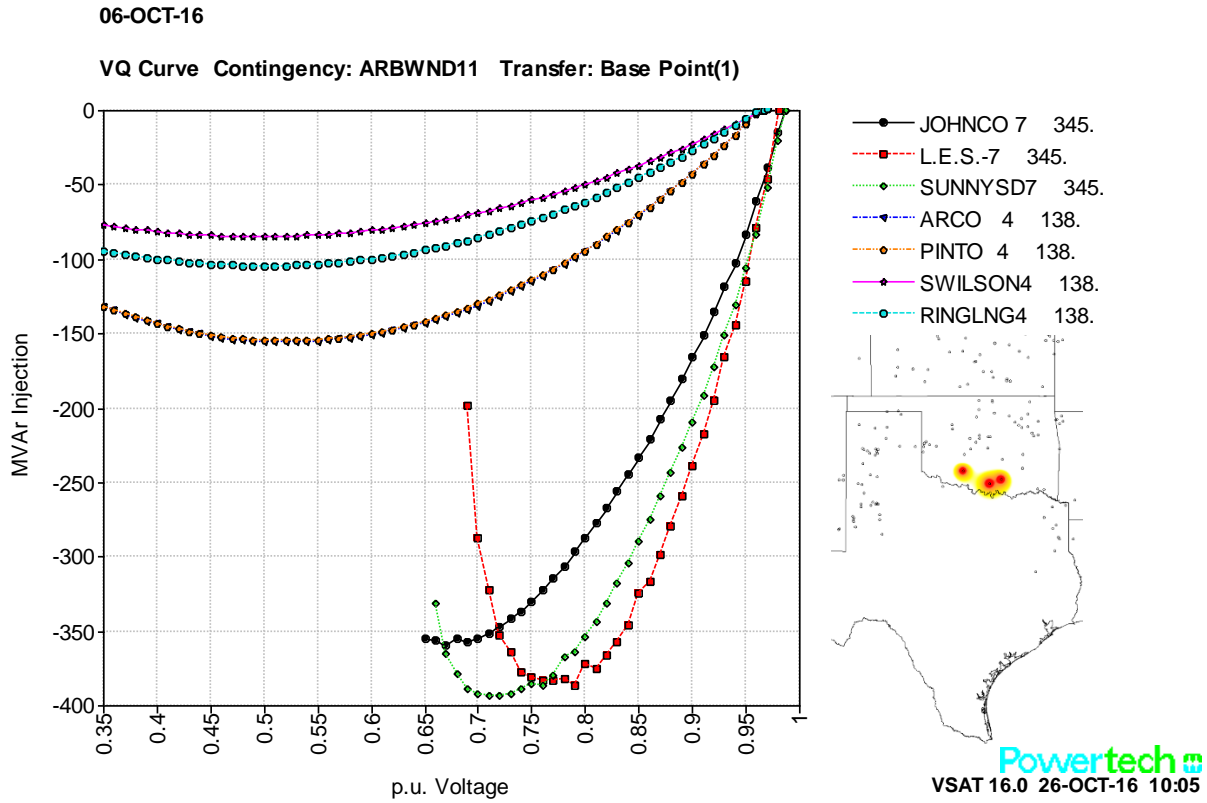

Figure 8.9.3: G-1 Q-V Curves – Base Point

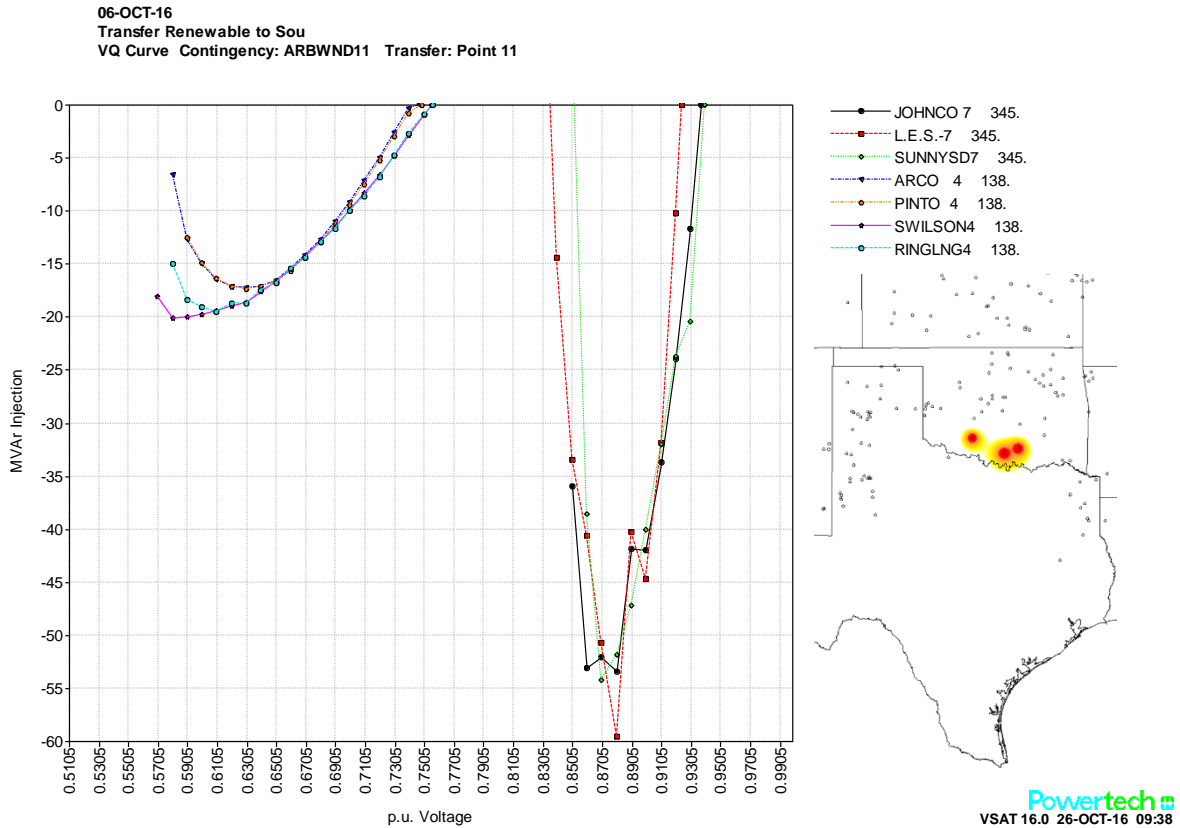

Figure 8.9.4: G-1 Q-V Curves – 95% Point (ATC=485MW)

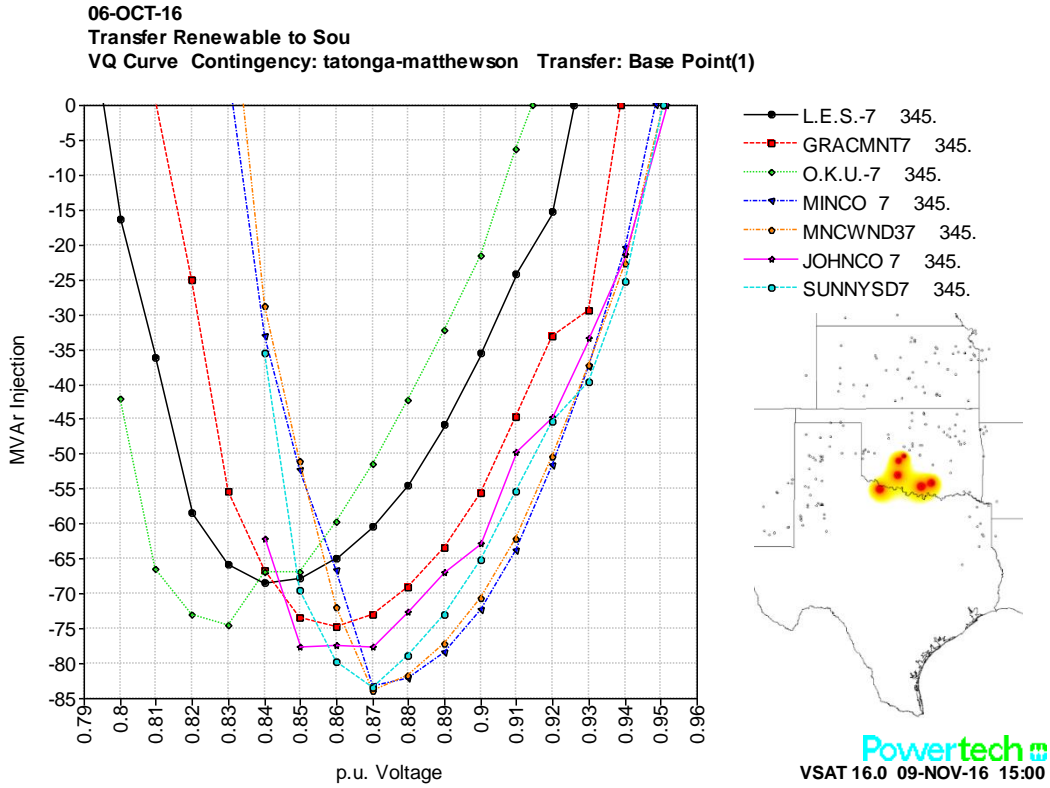

Figure 8.9.5: T-1 Q-V Curves – Base Point

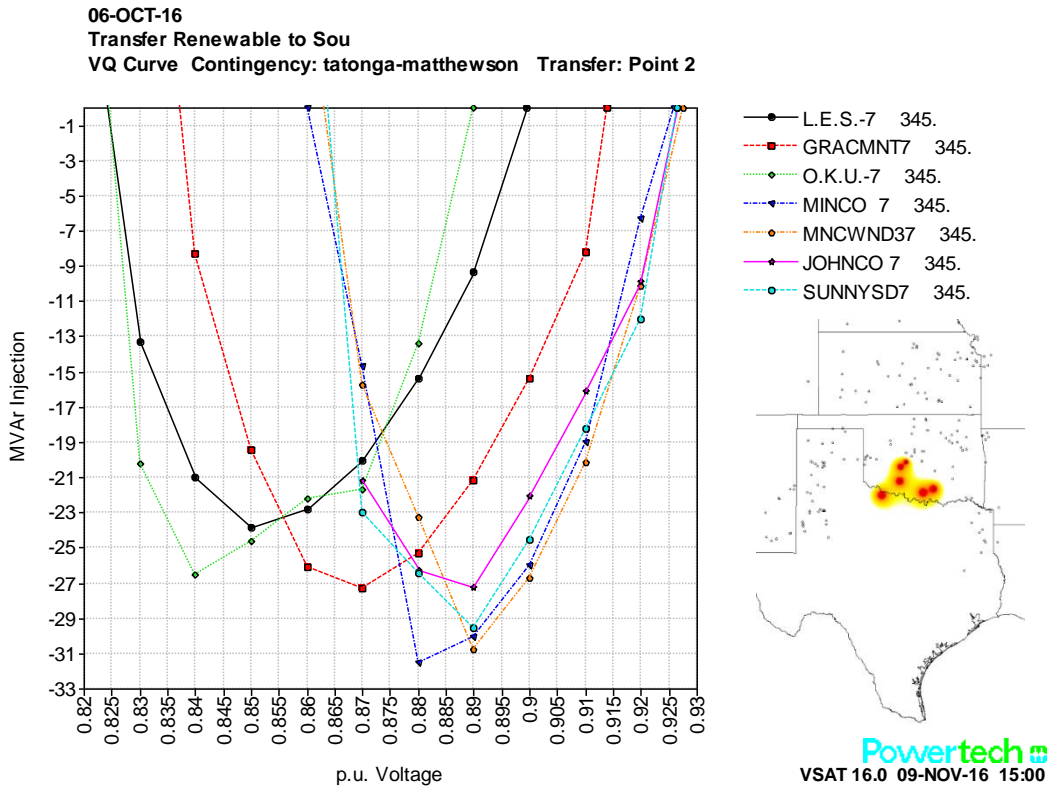

Figure 8.9.6: T-1 Q-V Curves – 95% Point (ATC=38MW)

8.9.1 Inclusion of Woodward Phase Shifter

8.9.1.1 Base Case Re-Dispatch

The base power flow used for this study starts with the same power flow as in 8.5 *BASECASE RE-DISPATCH* section in this chapter. However, additional changes were made are discussed below.

1. The Woodward phase shifter operating at 15 degrees was added between buses WOODWRD4 138kV. and WWRDEHV4 138kV.
2. **WOODWRD4 138kV. - WINDFRM4 138kV ftlo TATONGA7 345kV. - MATHWSN7 345kV.**

It was found that this phase shifter completely relieves this overload in base case. Therefore the basecase re-dispatches made for this overload were not needed and were not applied. Therefore the MORLND4 18.0, CENT 21 34.5, and OUSPRT 1 34.5 units where not re-dispatched.

3. **ELKCITY6 230kV. - ELKCTY-4 138kV. Overload ftlo. O.K.U.-7 345kV. - L.E.S.-7 345kV.**

The addition of the phase shifter caused this overload to go above 110%. This was relived with the re-dispatch shown below. Reduction of the DVER was insufficient to alleviate the overload, so the NDVER was also scaled down. (Note: later it was stated by AEP that the rating should be 331MVA instead of 316MVA, which may have prevented the need for this action).

Type	Generator	Old	New	Switch On
DVER	ROARK1 34.5	76.37	60	N/A
NDVER	DEMPSEY1 34.5	103.29	80	N/A

4. Re-balancing of thermal and wind units to maintain wind penetration was then applied after the above changes were made.

8.9.1.2 Transfer Study

Initial Load	Study Type	Load Limit (old)	Load Limit (new)	ATC (old)	ATC (new)	Critical Contingency
244	G-1	754	864	510	620	ARBWND11 34.5 (80MW)
	T-1	284	434	40	190	TATONGA7 345. - MATHWSN7 345.
	Combined	244		0		

The G-1 critical contingency has remained the same with the same collapse in south Oklahoma. The ATC has increased by 90MW.

The T-1 critical contingency has remained the same with the same collapse in south (see Figure 8.8.2). The ATC has increased by 150MW.

Note however overloads above 110% were found in both the G-1 and T-1 transfers. The G-1 study experiences the first overload at an ATC of 550MW which was PAYNE 138kV. - PAOLI 4 138kV. in pre-contingency. The T-1 study experiences only one severe overload (TUPELO 4 138kV. - S

BROWN4 138kV. ftlo FROGVIL4 138kV. - HUGO PP4 138kV.) at 112% at the security limit (ATC of 190MW).

8.10 AREA3: SPS-SOUTH

Initial Load	Study Type	Load Limit	ATC	Critical Contingency
1599	G-1	2299	700	HOBBS_PLT3 118.0 (201MW)
	T-1	2199	600	CROSSROADS 7345. - EDDY_CNTY 7345.
	Combined	1599	290	

Table 8.10.1: Area 3 Results

G-1 outage of a Hobbs unit causes a collapse in the SPS region after a 700MW increase in wind. Modal analysis participation factors are plotted in Figure 8.10.1. Table 8.10.2 shows the 230kV buses participating in the collapse.

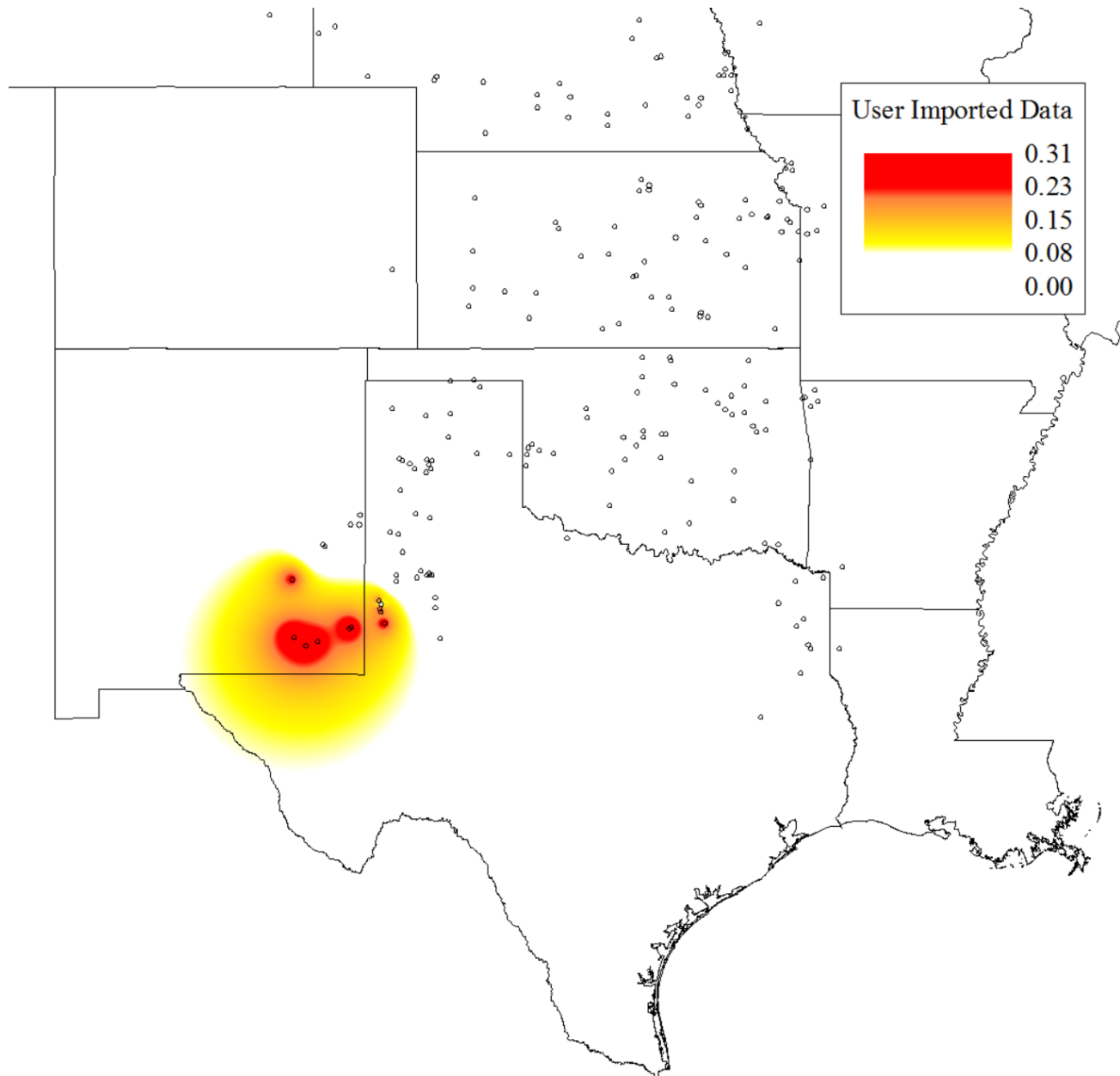

Figure 8.10.1: G-1 Modal Analysis Participation Factor Contour

Bus Name	KV Level
ANDREWS 6230.	230
7-RIVERS 6230.	230
PECOS 6230.	230
POTASH_JCT 6230.	230
RDRUNNER 6230.	230
CUNNIGHM_N 6230.	230
HOBBS_INT 6230.	230
EDDY_NORTH 6230.	230
CHAVES_CNTY6230.	230
SEMINOLE 6230.	230
MUSTANG 6230.	230
YOAKUM 6230.	230
BRU_SUB 6230.	230
AMOCOWASSON6230.	230

Table 8.10.2: G-1 Collapse – 230KV Buses

06-OCT-16

Bus Voltage (pu) Contingency: HOBBS_PLT3 Scenario: Area 3 - SPS South

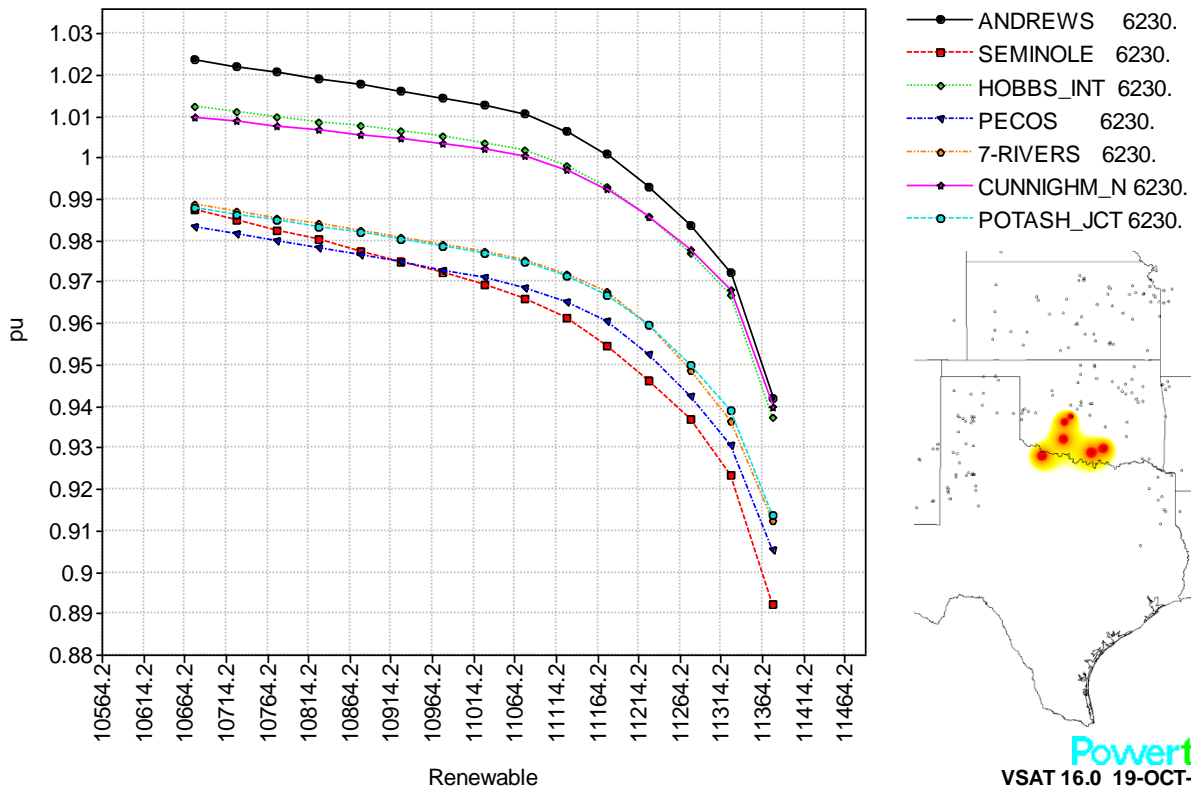

Figure 8.10.2: G-1 P-V Curves

Powertech
VSAT 16.0 19-OCT-16 17:06

For T-1 study, equivalencing of the 69kV system in the South SPS area was not trivial due to loops in the network topology. As the transfer progressed, some contingencies would cause collapse in the 69kV region as shown in Figure 8.9.1. These contingencies were:

- CUNNINGHAM 3 115kV. - BUCKEYE_TP 3 115kV.
- BUCKEYE_TP 3 115kV. - LE-TXACO_TP3 115kV.
- LE-SANANDRS3 115kV. - LE-TXACO_TP3 115kV.

SPS South has indicated that there are reverse power relays that would handle these situations. Therefore, the transfer was continued, and the next contingency was found to be CROSSROADS 7 345kV. - EDDY_CNTY 7 345kV after transferring 560MW. This causes a collapse in the South SPS area. Modal analysis results of this collapse is plotted Figure 8.10.4. The 230kV and 345kV buses participating in the collapse are shown in the Table 8.10.3.

Bus Name	KV Level
EDDY_CNTY 7345.	345
7-RIVERS 6230.	230
PECOS 6230.	230
EDDY_NORTH 6230.	230
CHAVES_CNTY6230.	230

Table 8.10.3: G-1 Collapse – 230KV and 345KV Buses

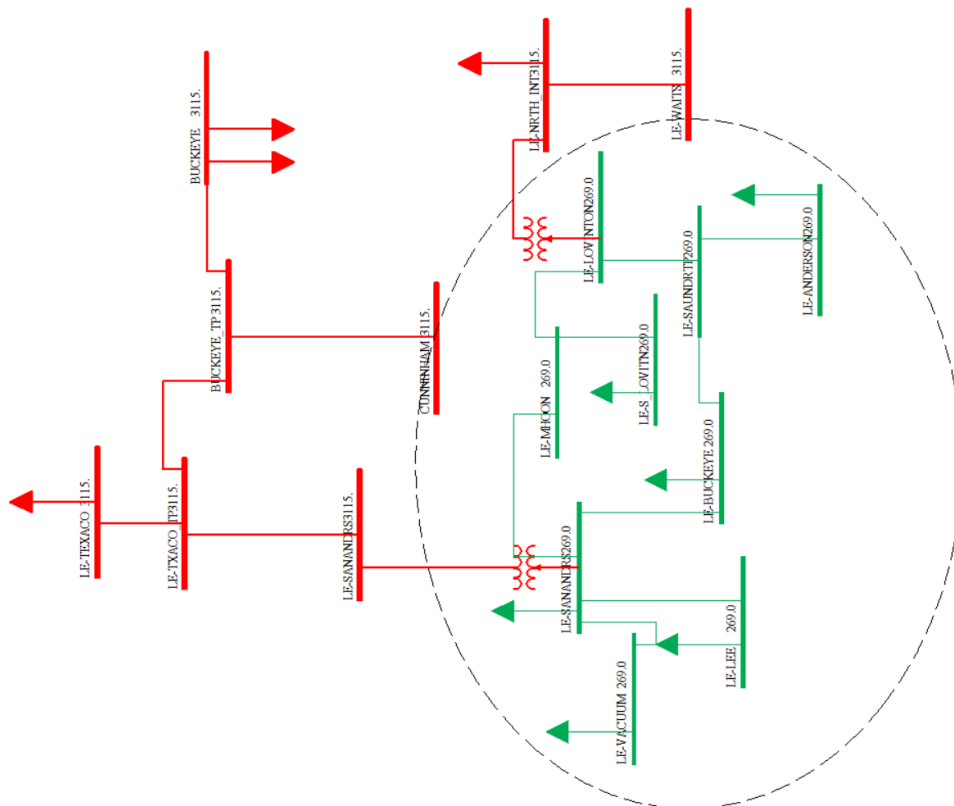

Figure 8.10.3: Local Collapse in 69KV system

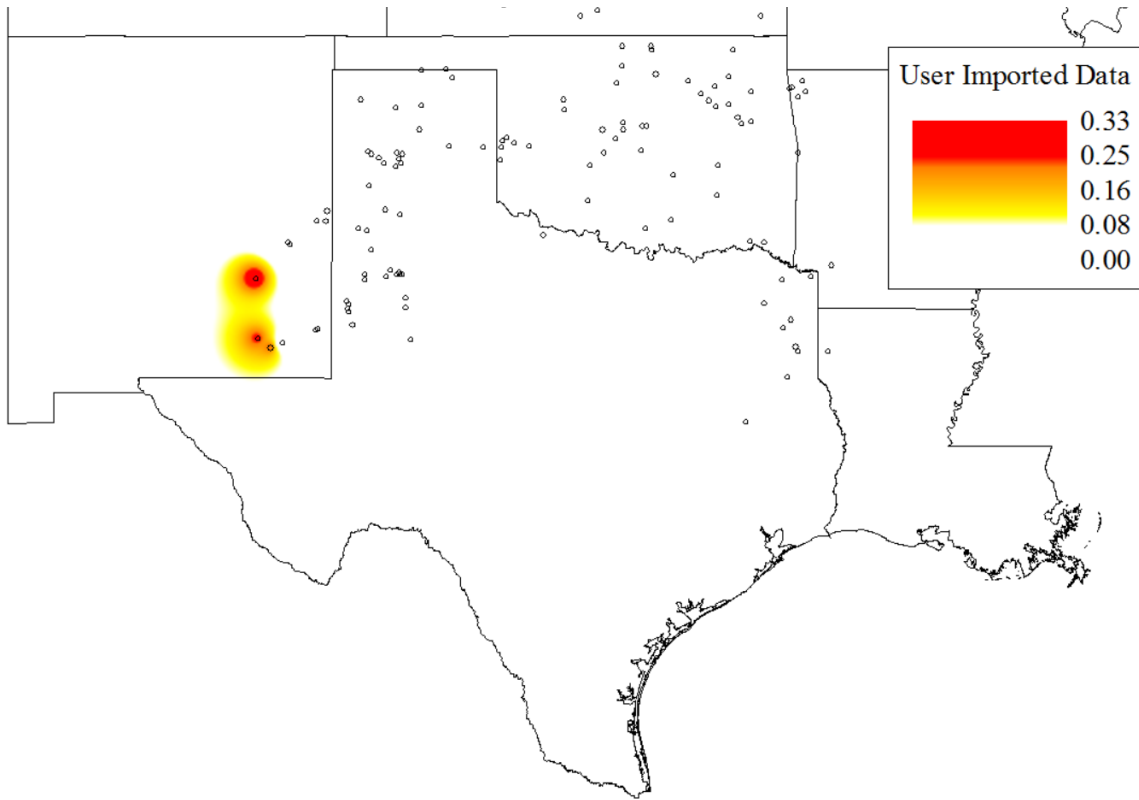

Figure 8.10.4: T-1 Modal Analysis Participation Factor Contour

06-OCT-16
 Bus Voltage (pu) Contingency: eddy-crossroads Scenario: Area 3 - SPS South

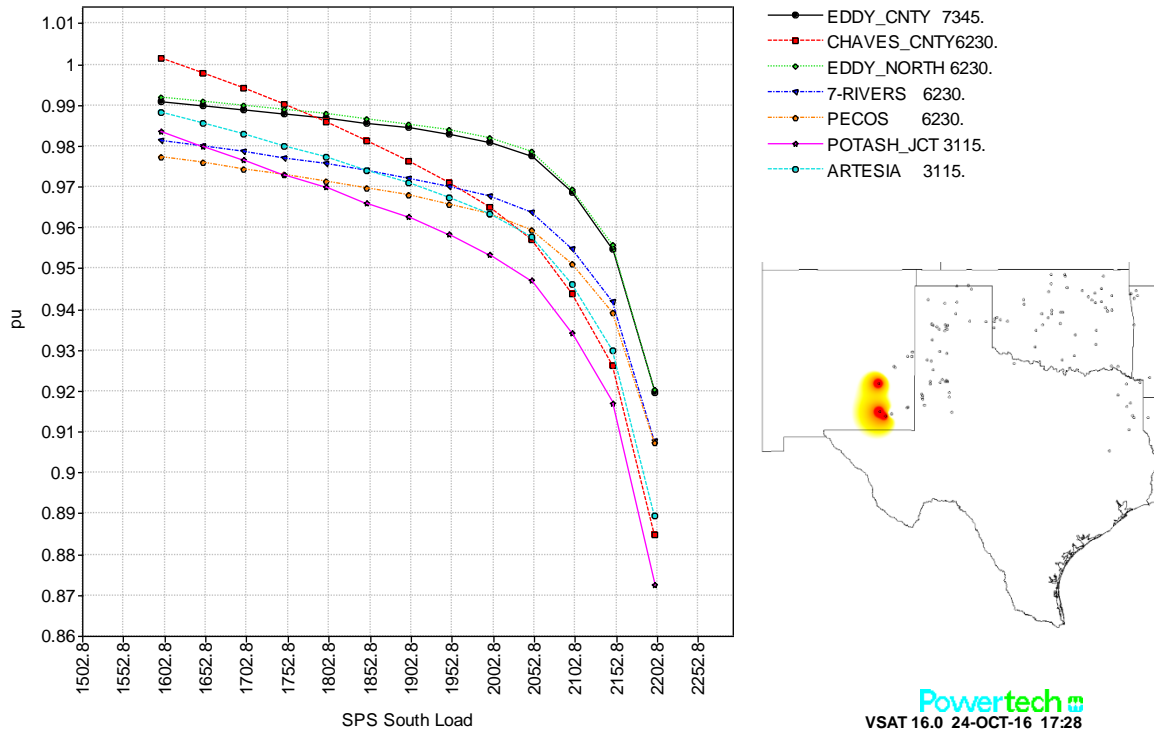

Figure 8.10.5: T-1 P-V Curves

The combined T-1 and G-1 study shows a collapse in the same region as the T-1 and G-1 combined (see Figure 8.10.6).

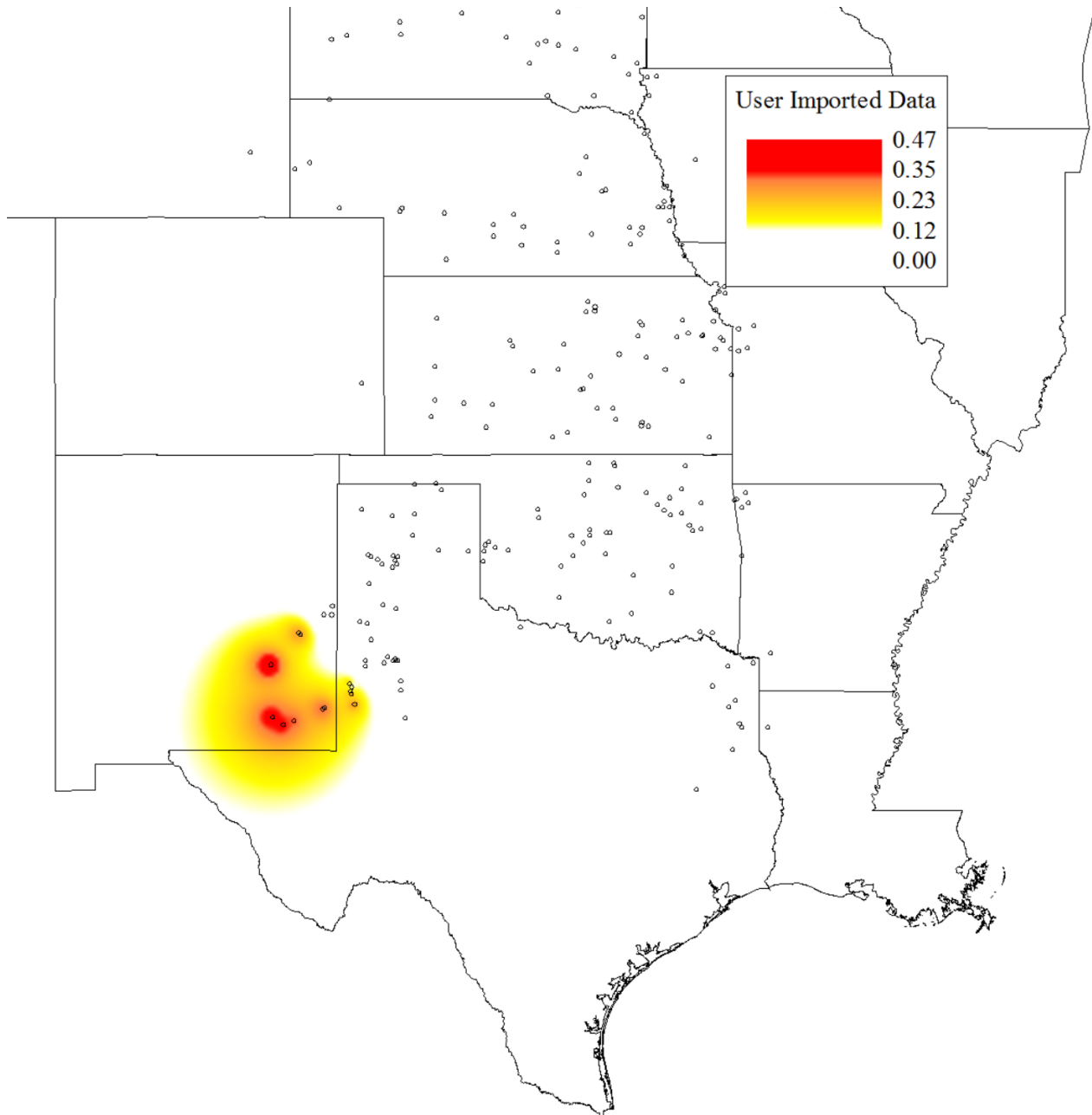

Figure 8.10.6: Combined Modal Analysis Participation Factor Contour

For the South SPS load pocket, both the G-1 and T-1 transfers experienced overloads above 110% as the transfer increased. These are believed to be due to load pocket scaling, as opposed to wind or thermal dispatch.

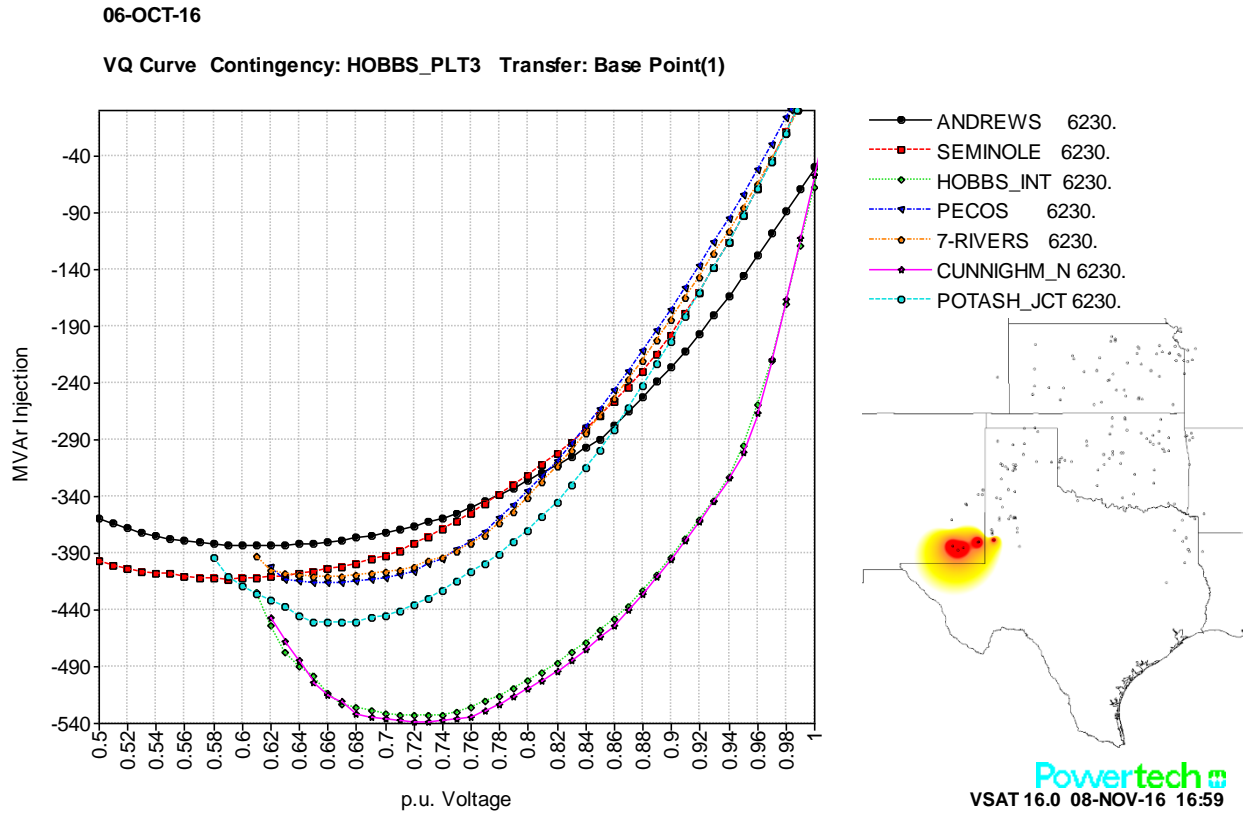

Figure 8.10.7: G-1 Q-V Curves – Base Point

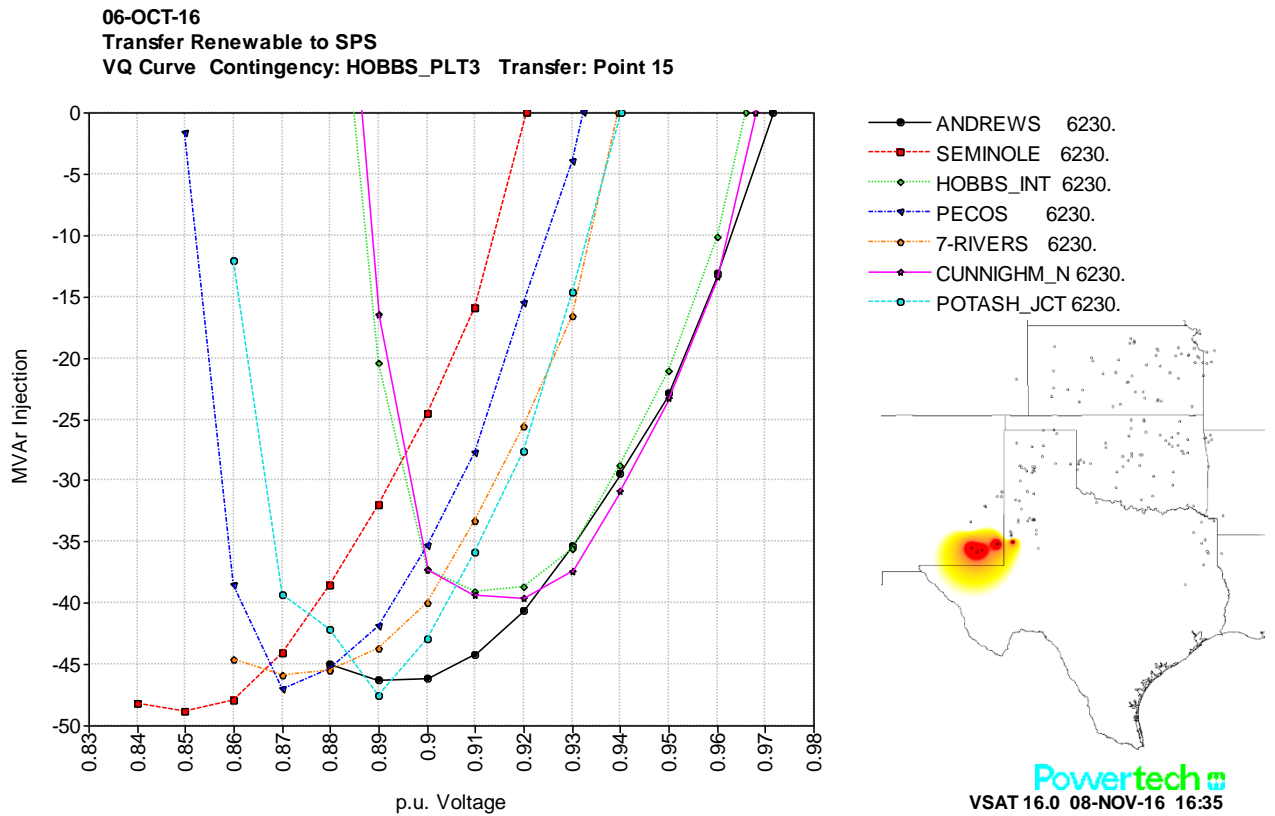

Figure 8.10.8: G-1 Q-V Curves – 95% Point (ATC=665MW)

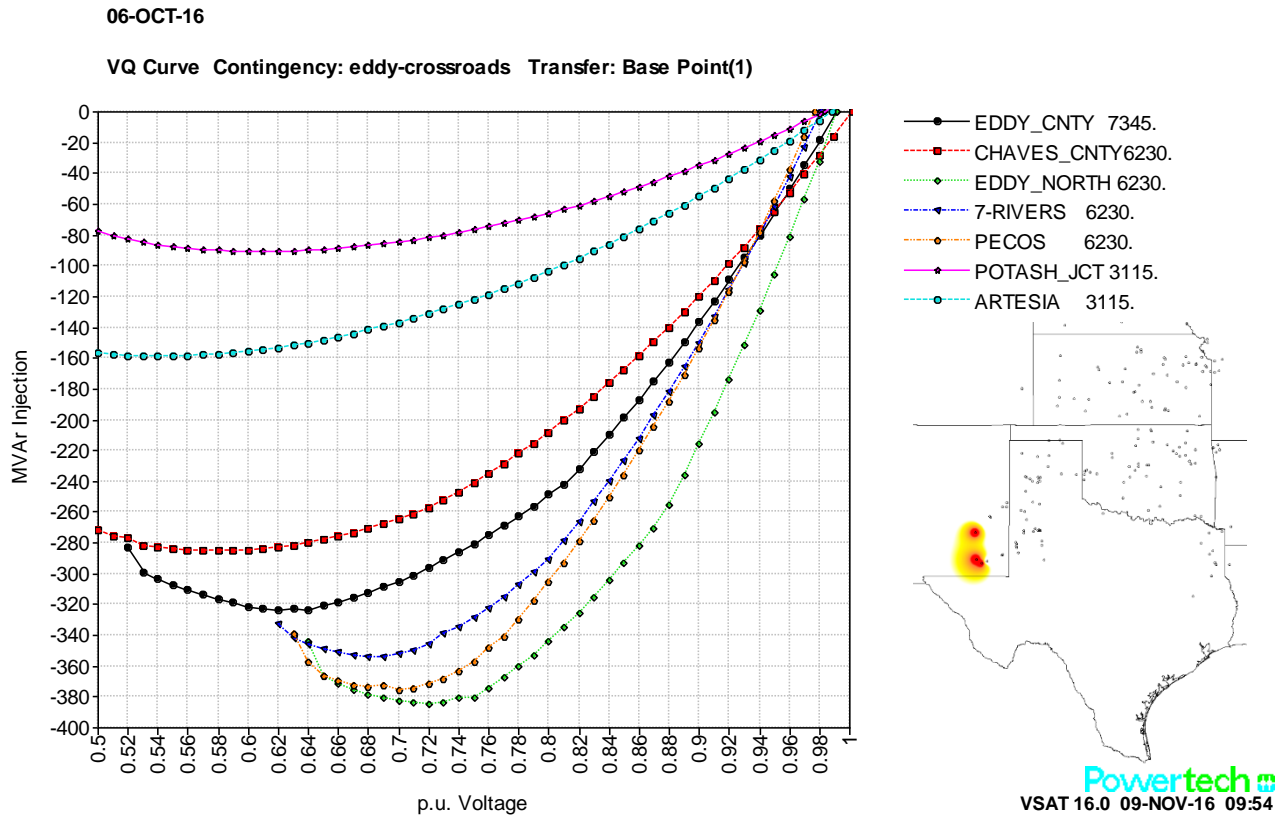

Figure 8.10.9: T-1 Q-V Curves – Base Point

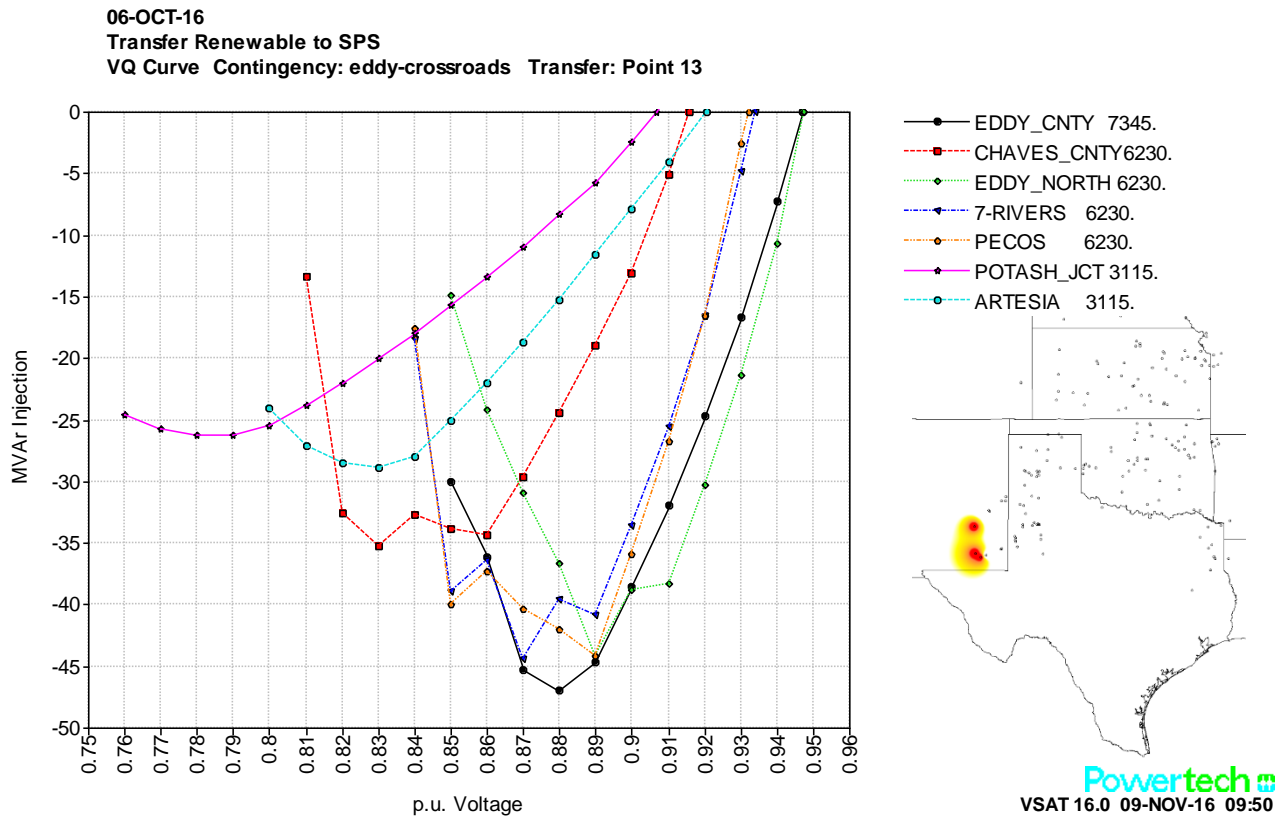

Figure 8.10.10: T-1 Q-V Curves – 95% Point (ATC=570MW)

The largest overload is SUNDOWN 6 230kV. - AMOCO_SS 6 230kV which was at 148% overload at the security limit (after 560MW transfer). The single-line diagram of this transmission line is shown in Figure 8.10.11, where a large load is found on the AMOCO bus. Due to this load’s original size being large, this load would pick up a lot of the load scaling during the transfer. At the security limit, it increased by 60MW to reach an overall size of 232MW.

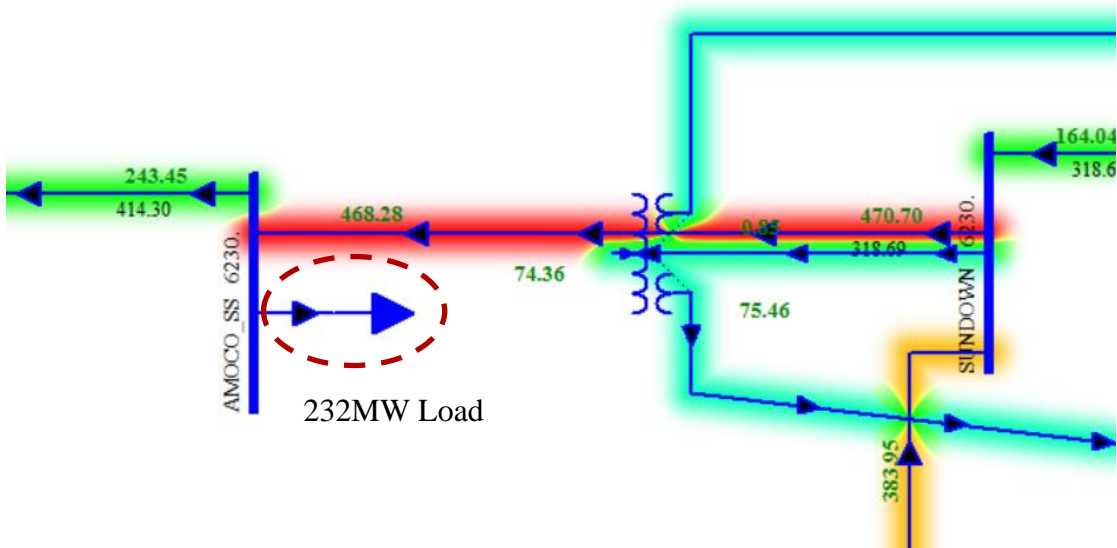

Figure 8.10.11: Overload Due to Large Scaled Load

Interestingly, for this load pocket, the *Tatonga to Matthewson* contingency does not cause a collapse until ~1000MW of transfer.

8.10.1 Amoco Load Correction

The load at Amoco_SS was corrected to be non-scalable and set to be 130MW and 15MVAR (previously 172MW and 29.34MVAR). Note, since the load is not scalable, it is not included in the calculation of total “initial load”. After this correction, the studies done on this load pocket were re-run. The updated results are shown below.

Initial Load	Study Type	Load Limit	ATC	Critical Contingency
1427	G-1	2097	670	HOBBS_PLT3 118.0 (201MW)
	T-1	1997	570	CROSSROADS 7345. - EDDY_CNTY 7345.
	Combined			

Table 8.10.4: Area 4 Results

The limiting G-1 contingency was still the Hobbs unit; however the ATC is now 670MW instead of 700MW with the same collapse region as shown in Figure 8.10.1. However overloads above 110% began to occur at an ATC of 550MW. The overloads occurring were similar at the T-1 study discussed below; however the G-1 overloads were much less severe.

The limiting T-1 contingency also stays the same and the ATC increases to 570MW instead of 560MW. The collapse area remains the same as shown in Figure 8.10.4.

The overload at AMOCO_SS is now less in severity due to the load correction. Previously the first AMOCO_SS overload above 110% would occur at an ATC of 180MW. With the load correction, it now appears at an ATC of 370MW.

However, now that AMOCO_SS is not scalable, other loads in the load pocket will pick up its share. The first 110% overload now occurs at an ATC of 160MW (previously at 170MW). The only way to relieve these overloads is to further re-dispatch thermal units as there are no wind units in the immediate vicinity.

Figure 8.10.12 shows how the overloads get worst as the load pocket is scaled up. Since AMOCO_SS was the largest load, it would get the bulk of the load pocket scaling. In the case when AMOCO_SS was scalable, at the last secure point, would become overloaded in pre-contingency (therefore almost every contingency would also overload this line). Figure 8.10.12 indicates that the overloads are not just due to the AMOCO_SS load being scalable.

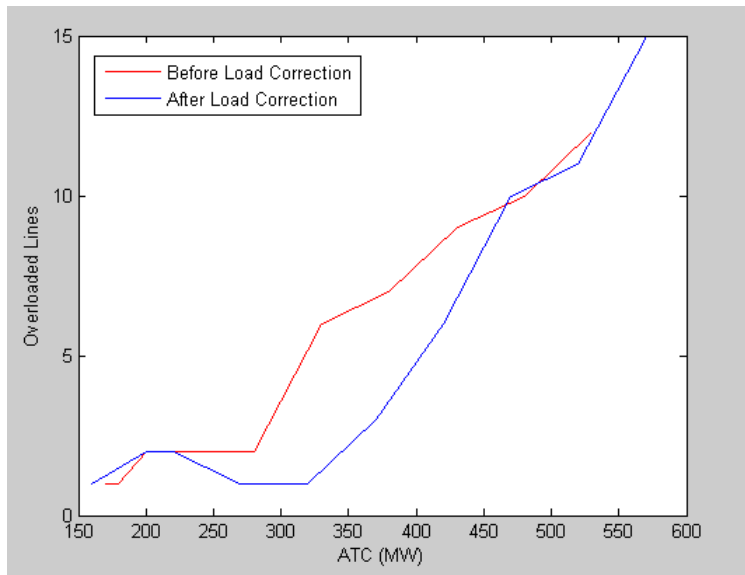

Figure 8.10.12: Number of Overload Lines (above 110%) as Transfer Progresses

With the load correction, the largest overload at the security limit was found to be 138% on CARLISLE 230kV. - CARLISLE 115kV. FTLO. TUCO_INT 230kV. - JONES 230kV. A wind unit was found nearby (see Figure 8.10.13). This wind unit was prevented from increasing with the transfer. However, this did not help, as the overload remained at ~138%.

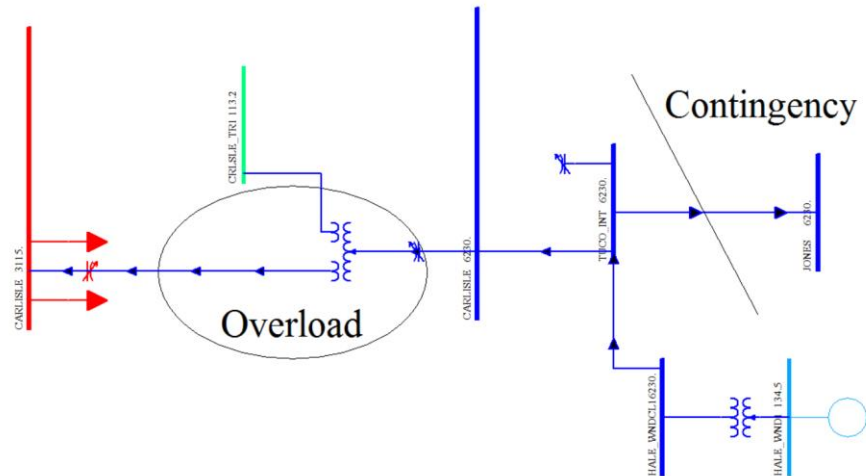

Figure 8.10.13: Worst Overloaded Line and Nearby Wind

In addition, similarly with before, there were some contingencies that caused collapse in the 69kV region, were it was assumed that some load shedding scheme would prevent voltage collapse. These ignored contingencies were:

- CUNNINGHAM 3 115kV. - BUCKEYE_TP 3 115kV.
- BUCKEYE_TP 3 115kV. - LE-TXACO_TP3 115kV.
- LE-SANANDRS3 115kV. - LE-TXACO_TP3 115kV.

8.11 AREA4: WEST OKLAHOMA

Initial Load	Study Type	Load Limit	ATC	Critical Contingency
80	G-1	529	450	MORLND3 18.0 (14MW Pmax=140MW)
	T-1	570	490	WWRDEHV7 345. - TATONGA7 345.
	Combined	499	420	

Table 8.11.1: Area 4 Results

The G-1 limiting contingency was a local voltage collapse in the 69KV system.

The T-1 limiting contingency was also a local voltage collapse in the 69KV system.

The combined study also collapses in the same area.

Typically equivalencing could help to obtain a true system wide voltage collapse. However, the G-1 and the T-1 transfers were already able to transfer past ~six times the base load (80MW to 450MW/490MW). It was determined that this was sufficient margin and no equivalencing should be attempted to further push the load pocket.

Also due to the sufficient MW margin, T-1 overloads above 110% occurring at an ATC of 470MW where ignored.

8.11.1 Inclusion of Woodward Phase Shifter

8.11.1.1 Base Case Re-Dispatch

The base power flow used for this phase shifter study was dispatched differently than the regular load pocket power flows, as detailed in section 8.9.1.1 Base Case Re-Dispatch.

8.11.1.2 Transfer Study

Initial Load	Study Type	Load Limit (old)	Load Limit (new)	ATC (old)	ATC (new)	Critical Contingency
80	G-1	529	469	450	390	MORLND3 18.0 (14MW Pmax=140MW)
	T-1	570	640	490	560	O.K.U.-7 345. - L.E.S.-7 345.
	Combined	499		420		

Table 8.11.2: Area 4 with Phase Shifter Results

The G-1 limiting contingency remained the same as the case without the phase shifter. The collapse area remains the same 69kV region in the Woodward region. However the ATC has decreased by 60MW.

The T-1 limiting contingency is now different however this was a very limiting contingency for the study without the phase shifter. The collapse region is in the south Oklahoma and Woodward region. Mostly 138kV buses were involved in the collapse, the 230KV bus is shown in the modal analysis plot in Figure 8.11.1. Similarly for the case without the phase shifter, overloads above 110% started occurring at an ATC of 200MW. The ATC has increased by 70MW.

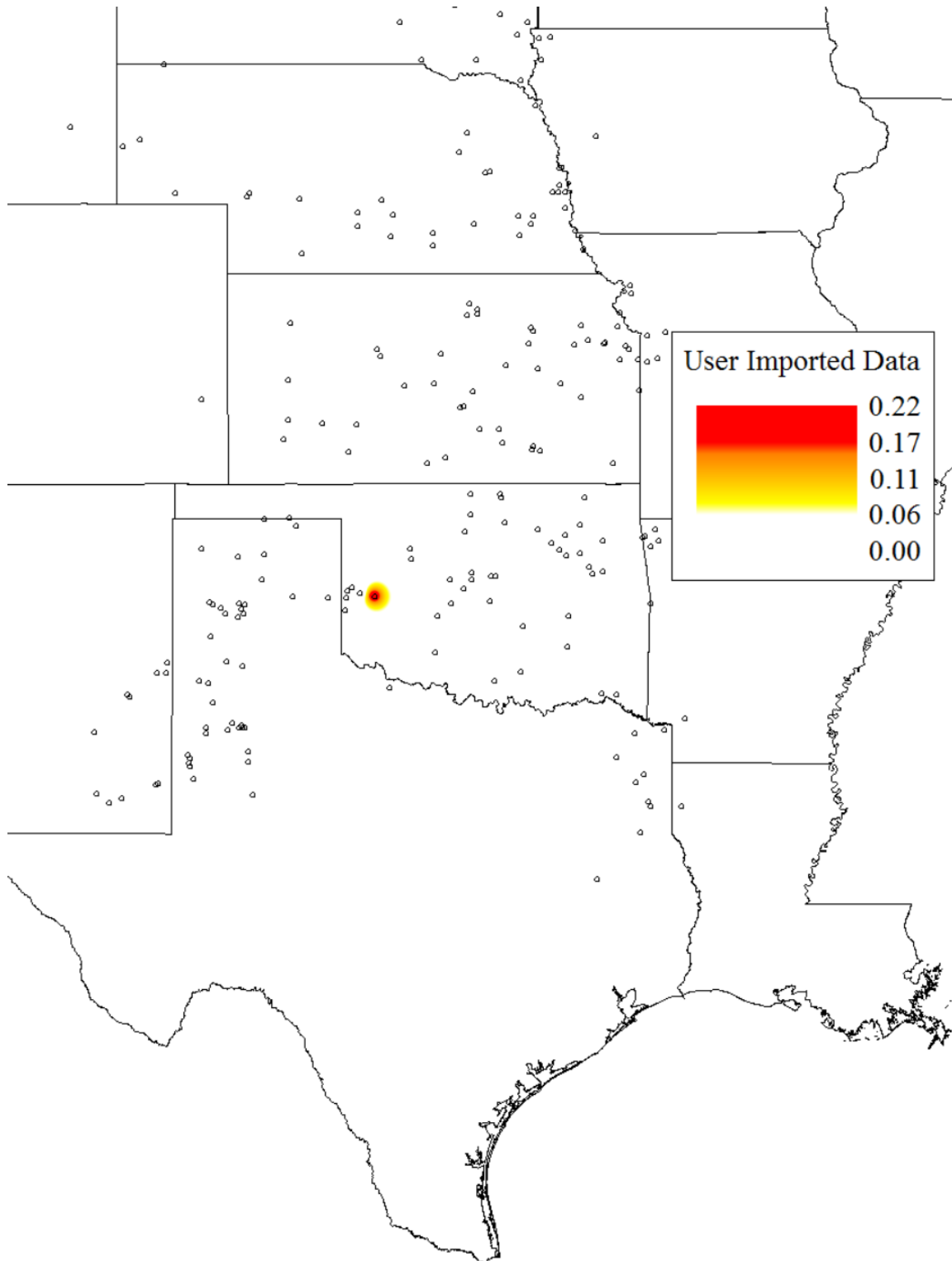

Figure 8.11.1: T-1 Modal Analysis Participation Factor Contour

8.12 AREA5: SOUTH CENTRAL WESTAR

Initial Load	Study Type	Load Limit	ATC	Critical Contingency
356	G-1	546	190	Wolf Creek (1190MW)
	T-1	496	140	TATONGA7 345. - MATHWSN7 345.
	Combined	356	0	

Table 8.12.1: Area 5 Results

This load pocket did not contain any in-service generators to use as G-1 contingencies. So instead, seven nearby generators were taken as the G-1 outages.

The G-1 limiting contingency was Wolf Creek, which is a large nuclear unit (1190MW). This MW loss will be picked up by wind and this causes a collapse in the south Oklahoma region.

The T-1 limiting contingency is similar to other load pockets. As described in area 1, the collapse is south Oklahoma.

The combined G-1 and T-1 study indicates that the severity of this combined contingency causes a collapse at the base point.

06-OCT-16
 Bus Voltage (pu) Contingency: Wolf Creek Scenario: Area 5 - Wichita

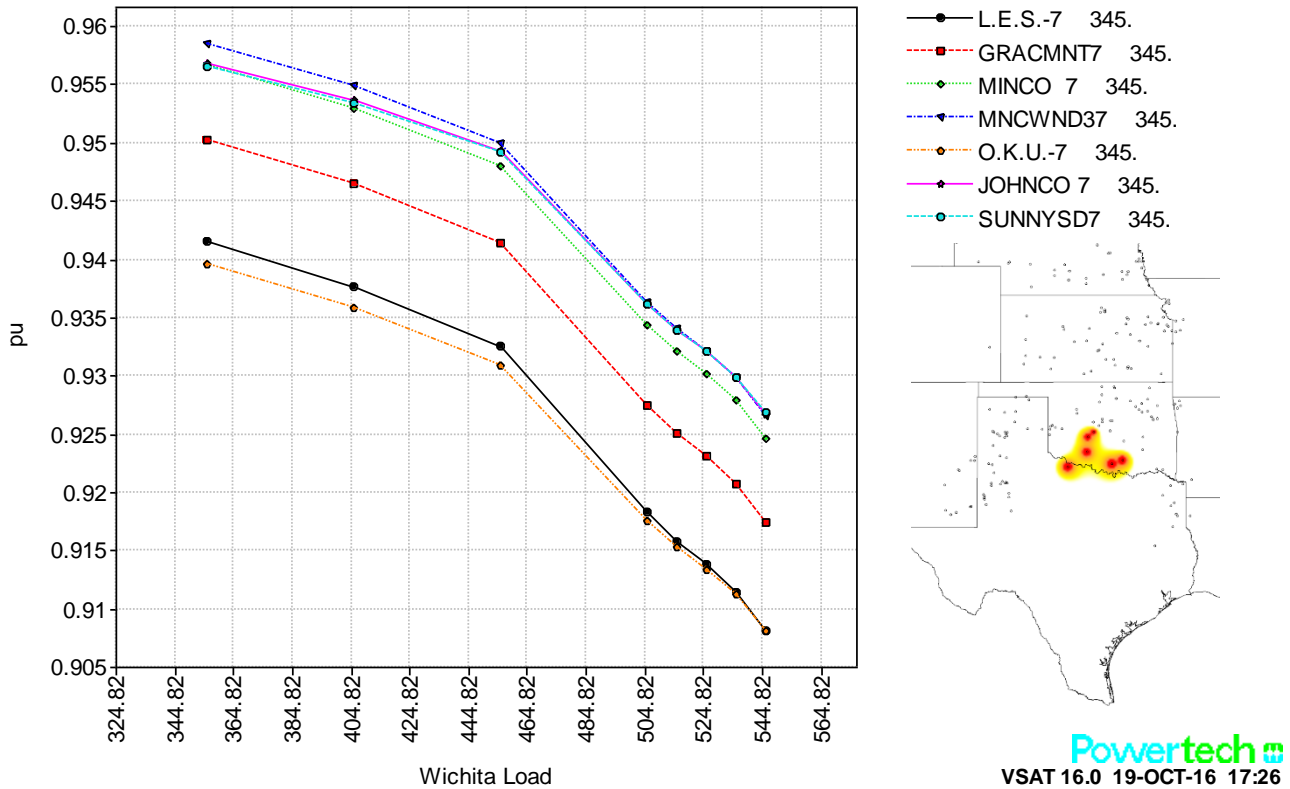

Figure 8.12.1: G-1 P-V Curves

8.13 AREA6: KANSAS CITY

Initial Load	Study Type	Load Limit	ATC	Critical Contingency
2031	G-1	2581	550	IAT G2 1 25.0 (901MW)
	T-1	2181	150	TATONGA7 345. - MATHWSN7 345.
	Combined	2031	0	

Table 8.13.1: Area 6 Results

The G-1 limiting contingency is a large unit outputting 901MW. This MW loss will be picked up by wind and this causes a collapse in the south Oklahoma region.

The T-1 limiting contingency is similar to other load pockets. As described in area 1, the collapse is south Oklahoma.

The combined G-1 and T-1 study indicates that the severity of this combined contingency causes a collapse at the base point.

06-OCT-16
 Bus Voltage (pu) Contingency: IAT G2 1 Scenario: Area 6 - KansasCityMetro

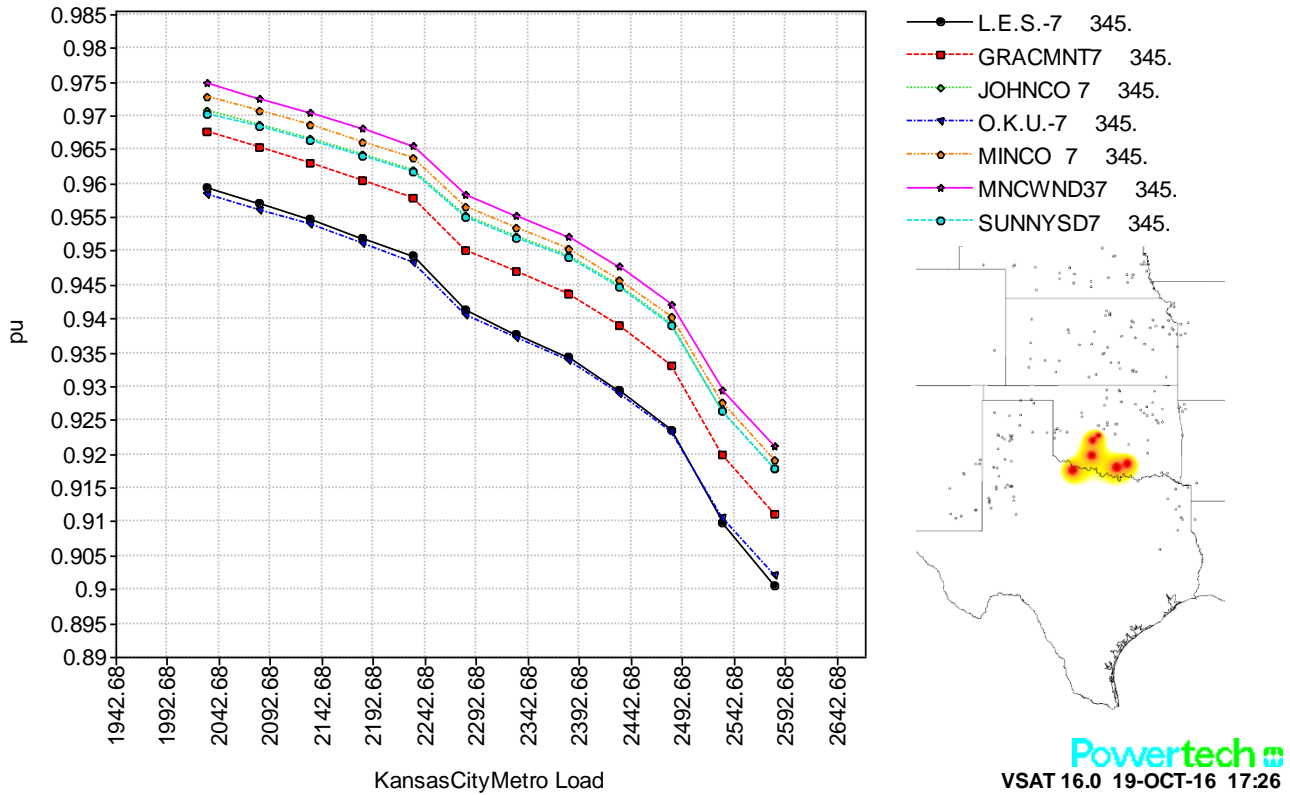

Figure 8.13.1: G-1 P-V Curves

8.14 AREA7: OKLAHOMA CITY

Initial Load	Study Type	Load Limit	ATC	Critical Contingency
899	G-1	1749	850	KNGFSR12 34.5 (160MW)
	T-1	959	60	TATONGA7 345. - MATHWSN7 345.
	Combined	899	0	

Table 8.14.1: Area 7 Results

The G-1 limiting contingency is a wind unit which causes a collapse in the south Oklahoma region of this load pocket.

The T-1 limiting contingency is similar to other load pockets. As described in area 1, the collapse is south Oklahoma.

The combined G-1 and T-1 study indicates that the severity of this combined contingency causes a collapse at the base point.

06-OCT-16
 Bus Voltage (pu) Contingency: KNGFSR12 Scenario: Area 7 - Oklahoma City

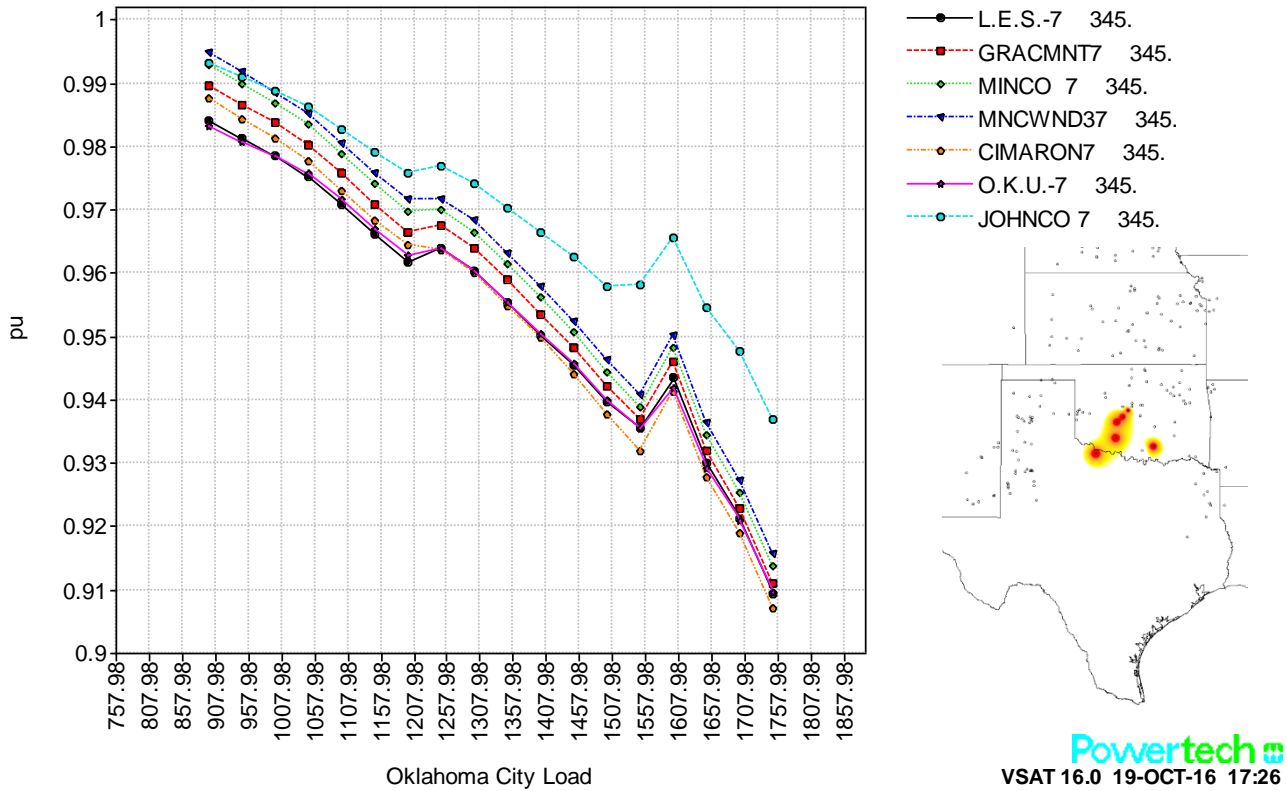

Figure 8.14.1: G-1 P-V Curves

8.15 AREA8: WILLISTON

Initial Load	Study Type	Load Limit	ATC	Critical Contingency
777	G-1	1617	840	LINDAHLWNDGW0.69 (36MW Pmax=151MW)
	T-1	947	170	TATONGA7 345. - MATHWSN7 345.
	Combined	887	110	

Table 8.15.1: Area 8 Results

The G-1 limiting contingency is a wind unit which causes collapse within the load pocket. Modal analysis participation factors are plotted in Figure 8.15.1.

The T-1 limiting contingency is similar to other load pockets. As described in area 1, the collapse is south Oklahoma.

The combined G-1 and T-1 study shows a collapse in the south Oklahoma region. Note that the T-1 is much more limiting, thus the combined study collapses in the same place as the T-1 collapse.

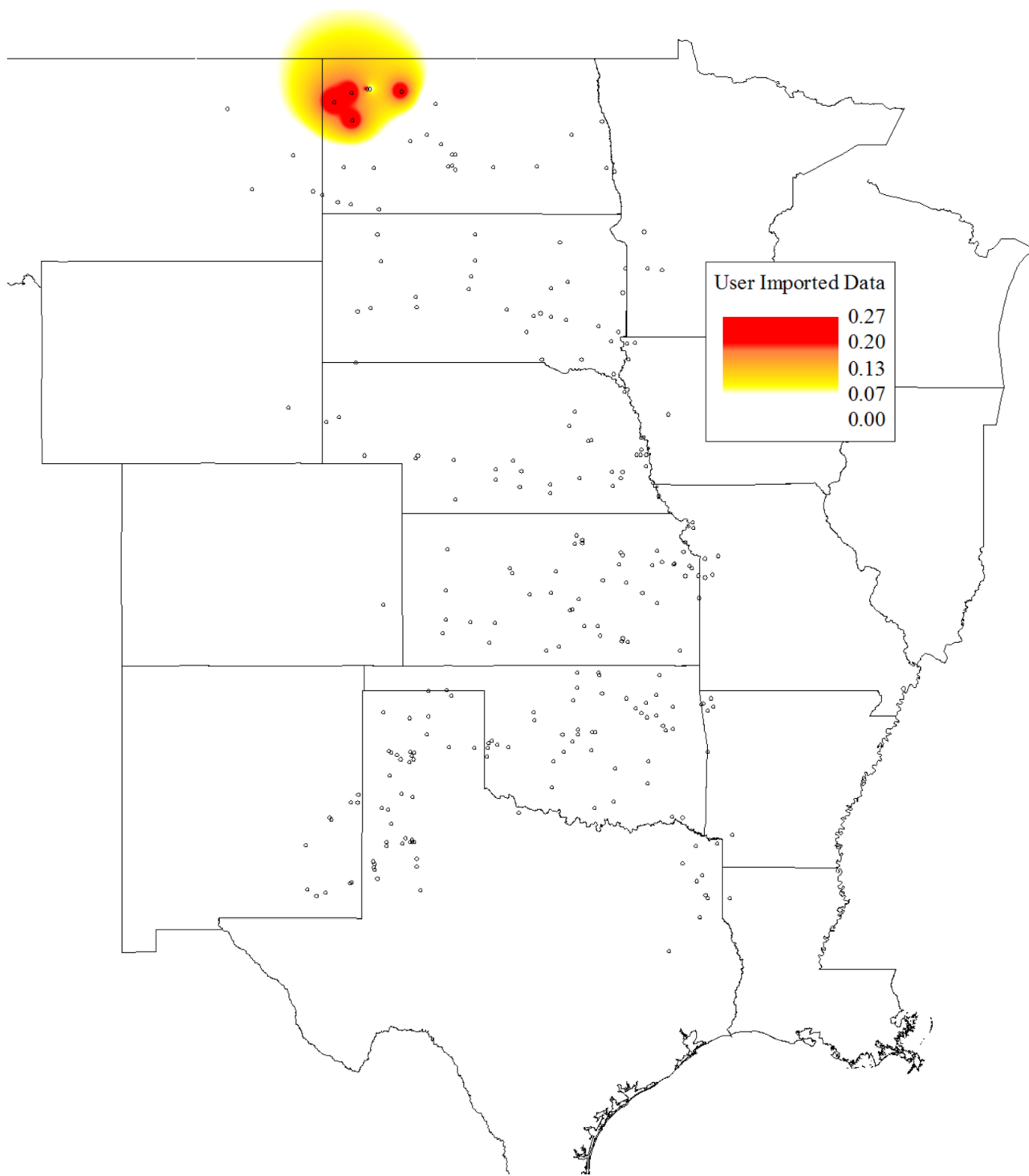

Figure 8.15.1: G-1 Modal Analysis Participation Factor Contour

06-OCT-16

Bus Voltage (pu) Contingency: LINDAHLWNDGW0.69 Scenario: Area 8 - Williston

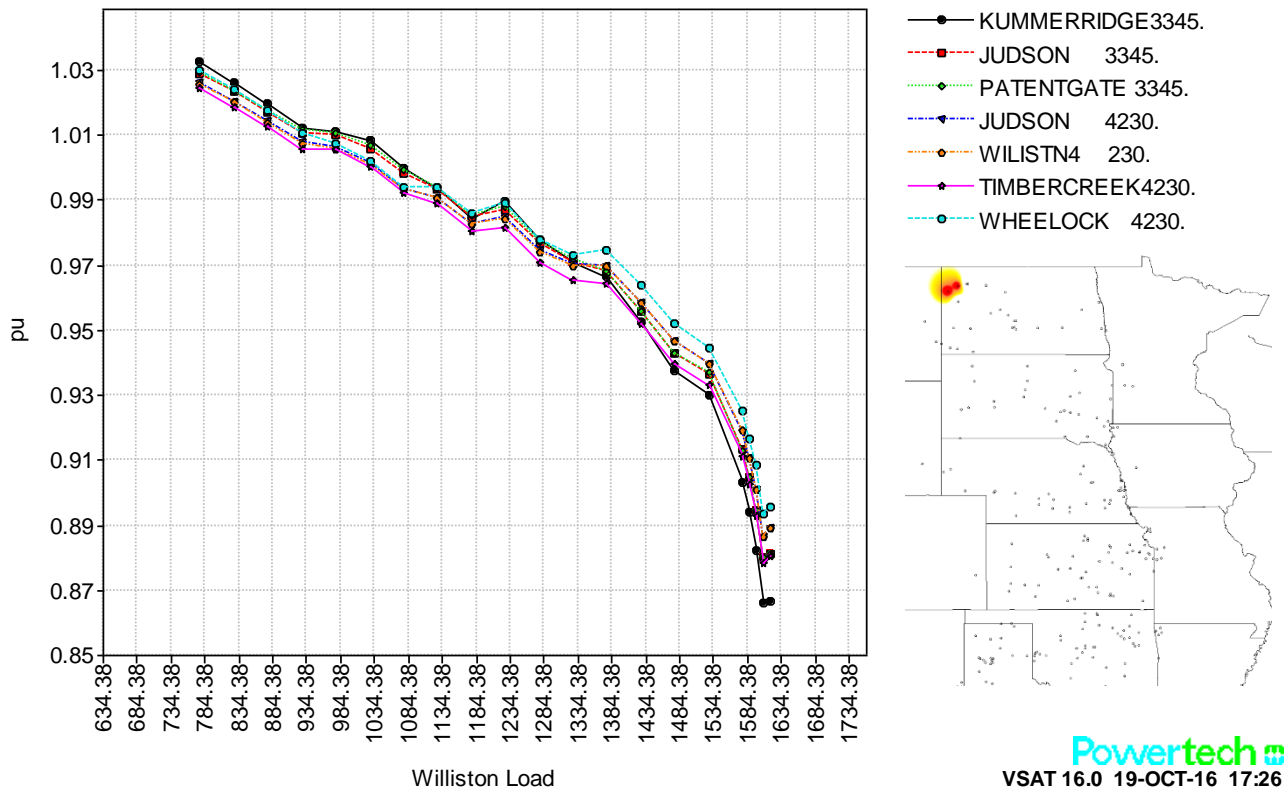

Figure 8.15.2: G-1 P-V Curves

Powertech
VSAT 16.0 19-OCT-16 17:26

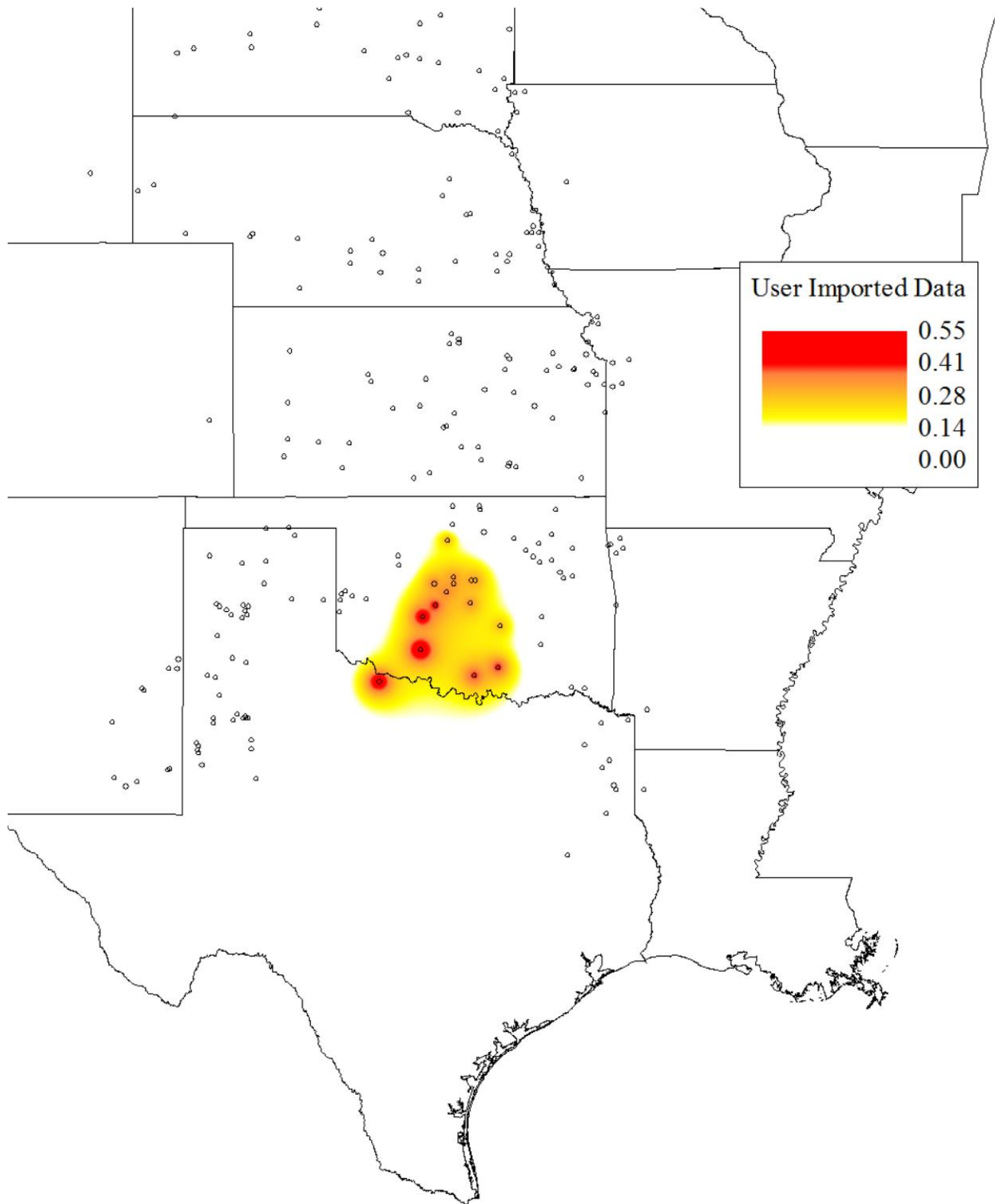

Figure 8.15.3: Combined Modal Analysis Participation Factor Contour

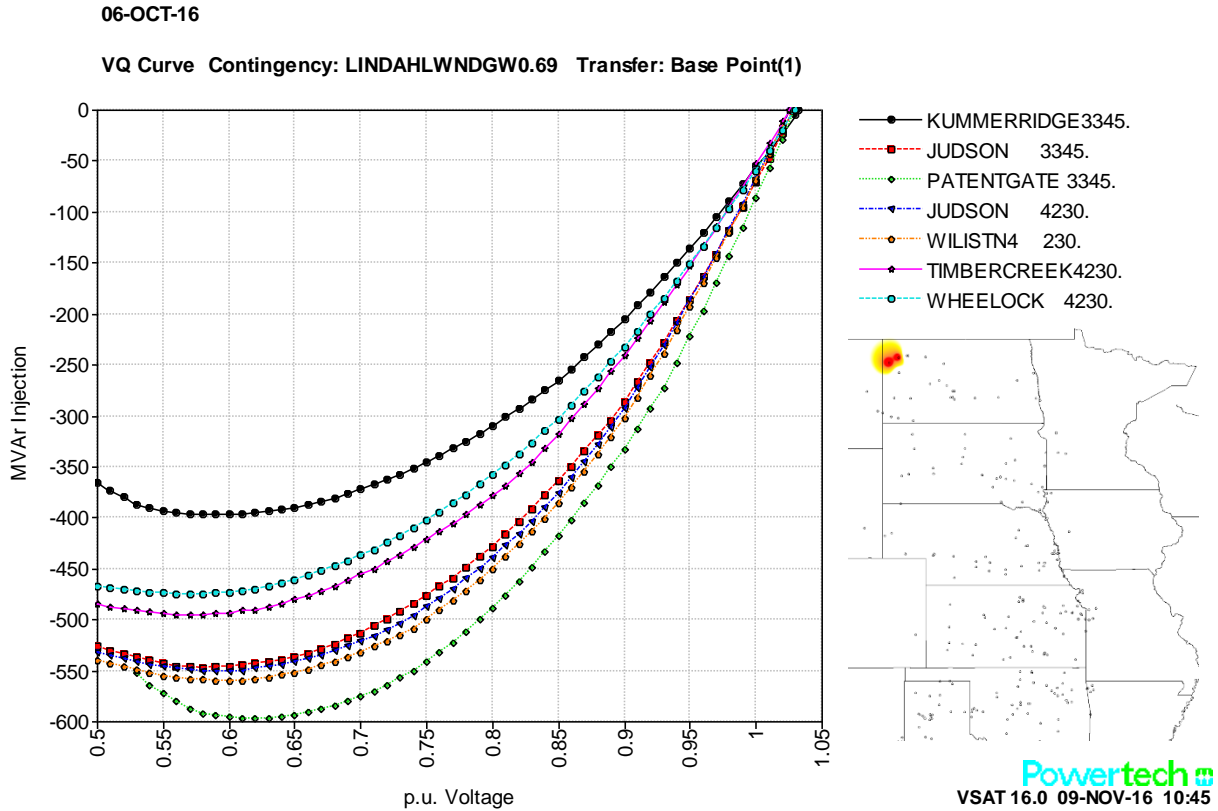

Figure 8.15.4: G-1 Q-V Curves – Base Point

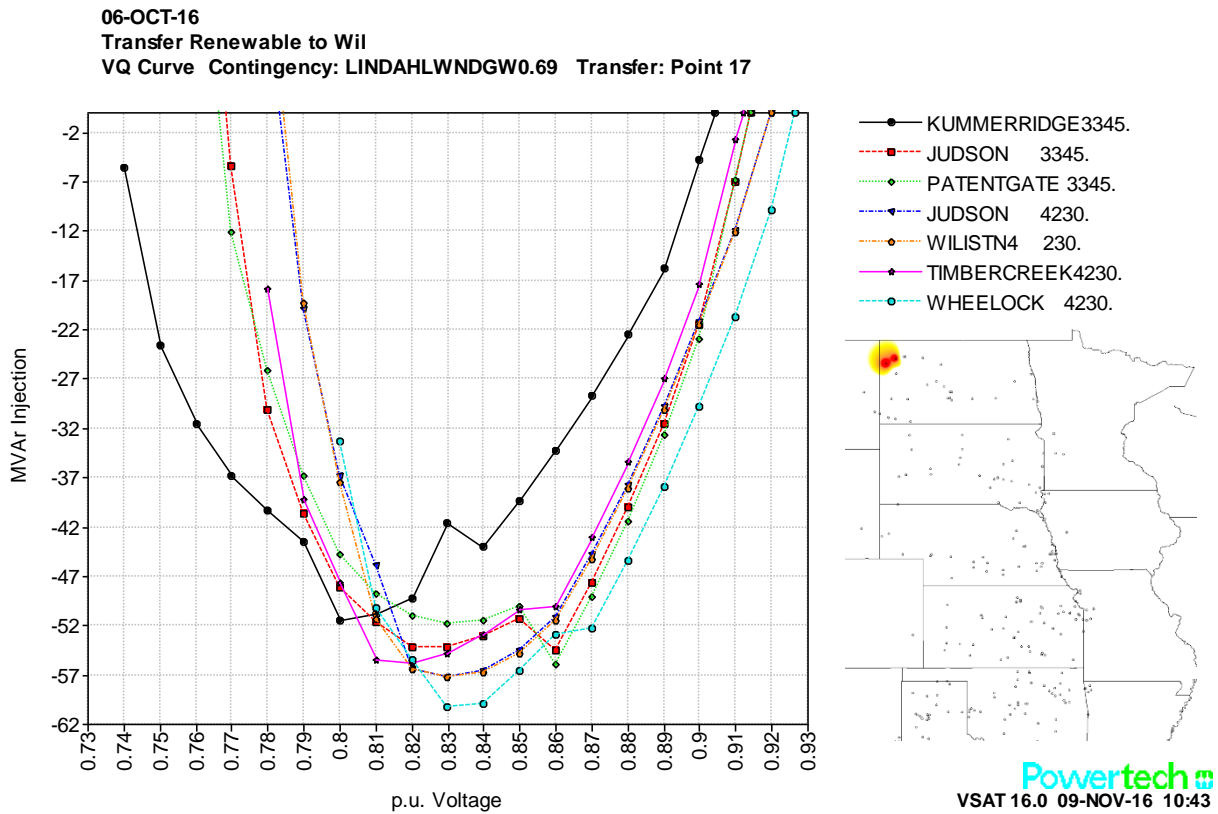

Figure 8.15.5: G-1 Q-V Curves – 95% Point (ATC=798MW)

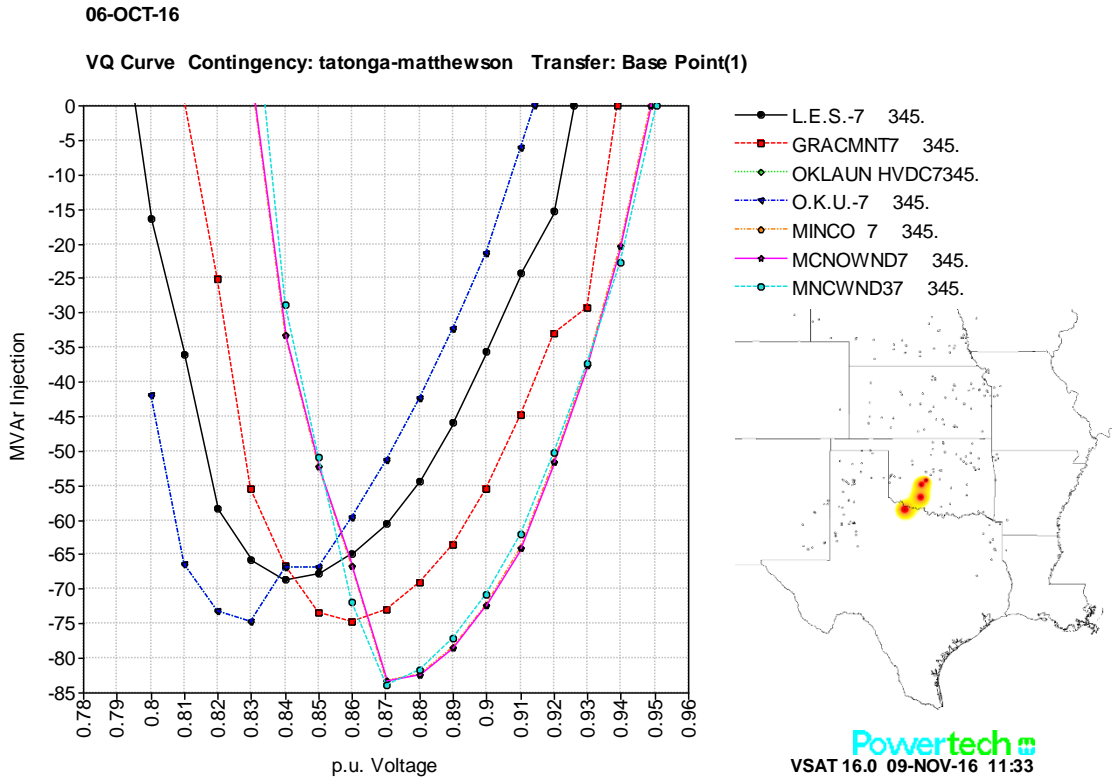

Figure 8.15.6: T-1 Q-V Curves – Base Point

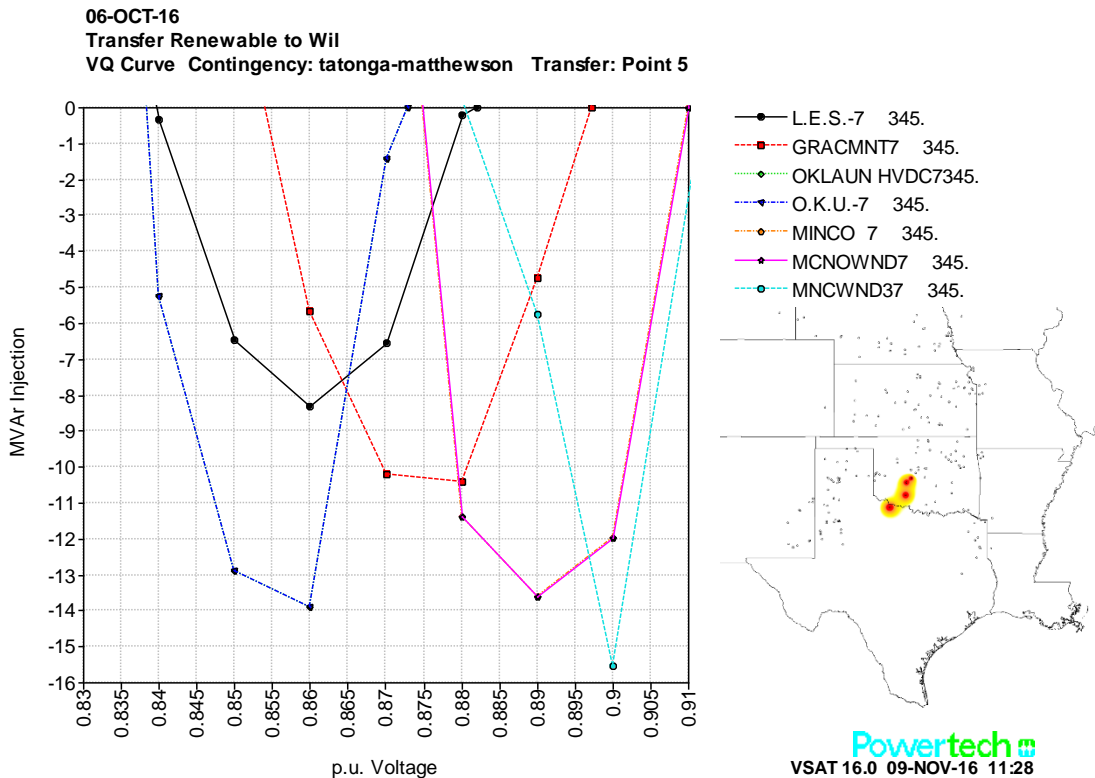

Figure 8.15.7: T-1 Q-V Curves – 95% Point (ATC=161.5MW)

8.16 SUMMARY

Load Pocket	Initial Load	Study Type	Load Limit	ATC	Critical Contingency
AREA1: EASTERN NEBRASKA	1059	G-1	2239	1180	NEBCTY2G 23.0 (499MW Output)
		T-1	1229	170	TATONGA7 345. - MATHWSN7 345.
		Combined	1059	0	
AREA2: SOUTH OKLAHOMA	244	G-1	754	510	ARBWND11 34.5 (80MW)
		T-1	284	40	TATONGA7 345. - MATHWSN7 345.
		Combined	244	0	
AREA3: SPS-SOUTH	1599	G-1	2299	700	HOBBS_PLT3 118.0 (201MW)
		T-1	2199	600	CROSSROADS 7345. - EDDY_CNTY 7345.
		Combined	1889	290	
AREA4: WEST OKLAHOMA	80	G-1	529	450	MORLND3 18.0 (14MW)
		T-1	570	490	WWRDEHV7 345. - TATONGA7 345.
		Combined	499	420	
AREA5: SOUTH CENTRAL WESTAR	356	G-1	546	190	Wolf Creek (1190MW)
		T-1	496	140	TATONGA7 345. - MATHWSN7 345.
		Combined	356	0	
AREA6: KANSAS CITY	2031	G-1	2581	550	IAT G2 1 25.0 (901MW)
		T-1	2181	150	TATONGA7 345. - MATHWSN7 345.
		Combined	2031	0	
AREA7: OKLAHOMA CITY	899	G-1	2581	850	IAT G2 1 25.0 (901MW)
		T-1	959	60	TATONGA7 345. - MATHWSN7 345.
		Combined	899	0	
AREA8: WILLISTON	777	G-1	1617	840	LINDAHLWNDGW0.69 (36MW)
		T-1	947	170	TATONGA7 345. - MATHWSN7 345.
		Combined	887	110	

Table 8.16.1: Load Pocket Study Summary

TARGETED 5 MINUTE ANALYSIS FUTURE RAMPING 5 YEAR OUTLOOK

9.1 OVERVIEW

Ramping analysis was performed to assess the ramping ability and system performance of SPP during various scenarios of high changes in variable generation. These studies were run with 5-minute granularity, using the existing market software and rules, with the focus on the times of highest ramp requirements over a four-hour window. Five sub-scenarios were run from each base, simulating ramps using 12, 15, 18, 21, and 24 GW of wind capacity. Solar capacity in the models was not significant enough to have an impact on the net load ramping (load ramp minus wind/solar ramp), so selected times of high ramp were based on wind. Scenarios analyzed were

- Summer load ramp up, with wind decreasing
- Fall/Spring evening load drop, with wind increasing
- Winter morning load increase, with wind decreasing

The outcome of this analysis should help identify potential risks to reliability and balancing management with higher penetration of variable generation as well as operational issues encountered that are not already covered by existing market rules and processes. These can be used to further develop any market rules, enhancements, or products that need to be implemented to ensure coverage of these risk areas.

9.2 MODELS USED

The 2021 VIS RAW models discussed previously in this report were used as the base model for the ramping scenarios. This was to ensure that topology and constraints were realistic based on expectations for five-years ahead. Resources that were announced to be retired by 2021 were not utilized in these scenarios, regardless of their status in the VIS base models to keep consistent with resource expectations. The base VIS models included 16 GW of wind capacity, which was not enough to meet the ramping requirements of the higher 21 and 24 GW capacity ramping scenarios. Additional wind generation that was registered in the SPP Integrated Marketplace by October 2016 was also included as capacity in these models to allow for more capacity and accurate geographic ramping distribution. This resulted in an additional 1.5 GW of wind capacity being added to the model for the ramping analysis, bringing the total wind capacity to roughly 17.5 GW wind capacity in the models.

9.3 SCENARIO DEVELOPMENT

Historical days were used to define the starting point for load and wind curve selection. The ramping analysis selected historical days that match scenario criteria and pull load profiles, wind profiles, and outages from those days. Selections for historical days were based off the worst net load ramps for the defined scenarios, assuming a 20 GW installed capacity of wind (20GW was selected as mid-to-high end of scenario scaling 12- 24 GW wind capacity). This was completed with the process below

1. The load, wind, and net load (load minus wind) values and ramps were calculated for the time frames 3/1/2014 – 7/31/2016. (Interchange was excluded from the calculations.)

2. The wind was normalized in the historical data based on registered capacity at the time, and then the net load was recalculated based on a total wind capacity of 20 GW (as opposed to the 7.5 – 12.5 GW that was present in the historical data).
3. With these new, modified net load curves, a peak day was selected for each scenario listed below, based on the largest (scaled) net load change over a 6 hour period in conditions that matched the initial scenarios (summer load ramp, fall/spring evening load drop, winter load increase). The use of a 6 hour period for the initial scenario selection (rather than 2, 4, etc.) was determined in order to find times that had both a high ramp over a short period of time as well as a longer duration, so it was more representative of an event where a large amount of rampable capacity would be depleted.

Scenarios (and selected historical days) considered for the ramping analysis are

- Summer load ramp up, with wind decreasing
 - Friday 6/17/16 (largest 6 hour net load increase during summer months, assuming 20 GW wind capacity)
- Fall/Spring evening load drop, with wind increasing
 - Sat/Sun 4/2-3/16 (largest 6 hour net load decrease in shoulder months, assuming 20 GW wind capacity)
- Winter morning load increase, with wind decreasing
 - Friday 12/14/15 (largest 6 hour net load increase in peak winter months, assuming 20 GW wind capacity)

Each of these three scenarios was run with five sub-scenarios, with wind forecast scaled assuming 12 GW (base), 15 GW, 18 GW, 21 GW, and 24 GW of wind capacity.

9.4 LOAD CURVES

Daily and hourly load curves were used for each internal area in the model based on the historical day selected. Load was captured for each internal area for those reference days, by hour and 5-minute interval of the day, and then a growth factor was applied to it based on load growth in the 2016-series MDWG models between the relevant seasons for 2016 and 2021. For example, if an area showed 2,000 MW of load in the 2016 summer season and 2,200 MW of load in the 2021 summer season, then a 10% growth factor for that area was used in the studies. The hourly load curves used in the scenarios are shown below. Note that 7 days are shown (which were used in the commitment analysis), but only ramping on the first day was analyzed at 5-minute granularity. This first day included the identified 4-6 hour ramping period that was the basis for the curve selections.

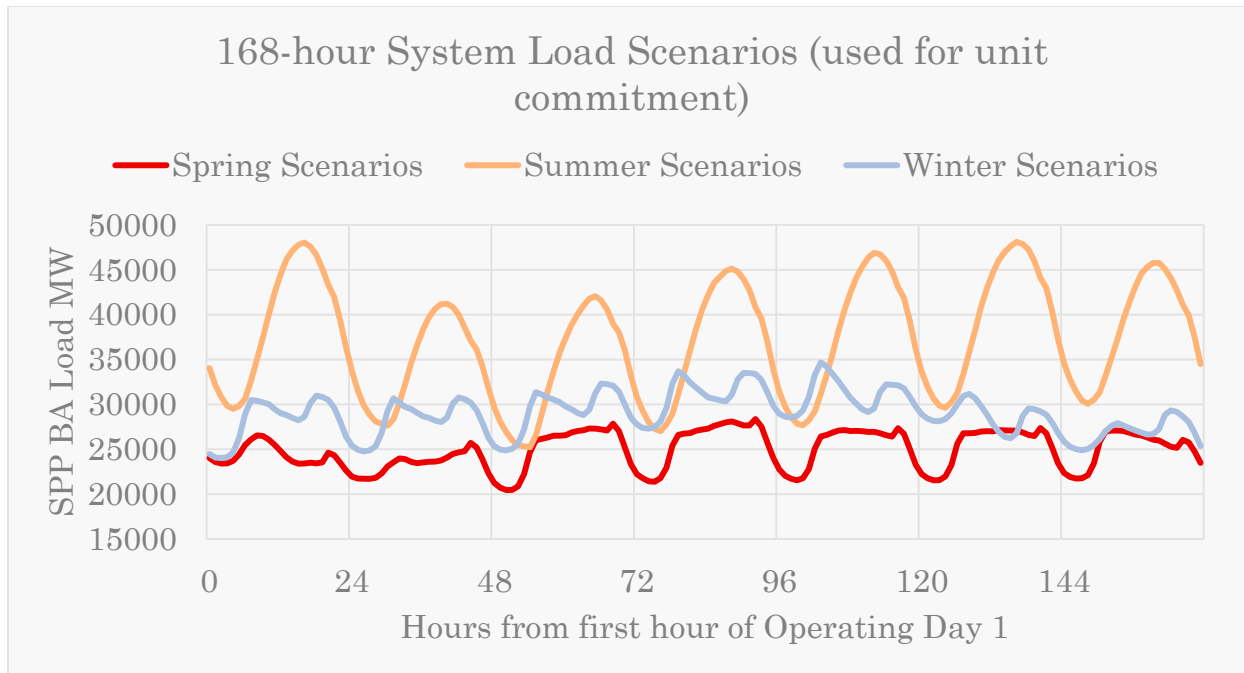

9.5 RESOURCE FORECAST CURVES

Resource forecast were also used based on historical data from the same profile days. The reference days selected provided the basis for a top-down forecast approach, where total system forecast was scaled incrementally. Forecasts for wind and solar had to be developed independently from each other, below are the steps used (using wind forecast as the example) to go from the top-down system-level forecast to distribute the generation out to each individual resource. The use of short-term (5 minute) forecasts instead of actual resource outputs as a reference was necessary to eliminate the impact of curtailments in the base data.

1. Get base resource forecast from reference historical data (this was using a 12-GW capacity)
2. Scale system total peak forecast for each sub-scenario, increasing the forecast linearly with total system capacity, while observing the same minimum forecast that occurred during that 7-day window. (Charts on the following pages may provide a better visual to describe how this was done.)
3. This total forecast was then distributed to each wind resource based on their capacity factor at each interval in the historical data, as well as that resource’s participation in the total system forecast at the time.
 - a. Resources that were not online yet or operational at the time of the historical data (and thus did not have reference capacity/participation factors) used the aggregate capacity factor from online wind resources in their reserve zone region.

This methodology was used for both solar and wind forecasts separately for the individual resource distribution, though wind forecast was the only set that was scaled to a different value in all five sub-scenarios of each seasonal scenario. These were also performed at both the 5-minute and hourly interval level.

Below is a table showing the minimum (or maximum) wind forecast ramp in each sub-scenario. Note that the spring scenario was focused on a high ramp-up in wind, so the net load ramps are positive.

Scenario	Base (12 GW)	15GW	18GW	21GW	24GW
Summer	-4,822	-6,027	-7,233	-8,438	-9,644
Spring	6,165	7,707	9,248	10,789	12,331
Winter	-4,151	-5,188	-6,226	-7,264	-8,302

Winter scenario wind forecast chart; the 05:30 – 10:00 range is the focus of the 5-minute ramping analysis.

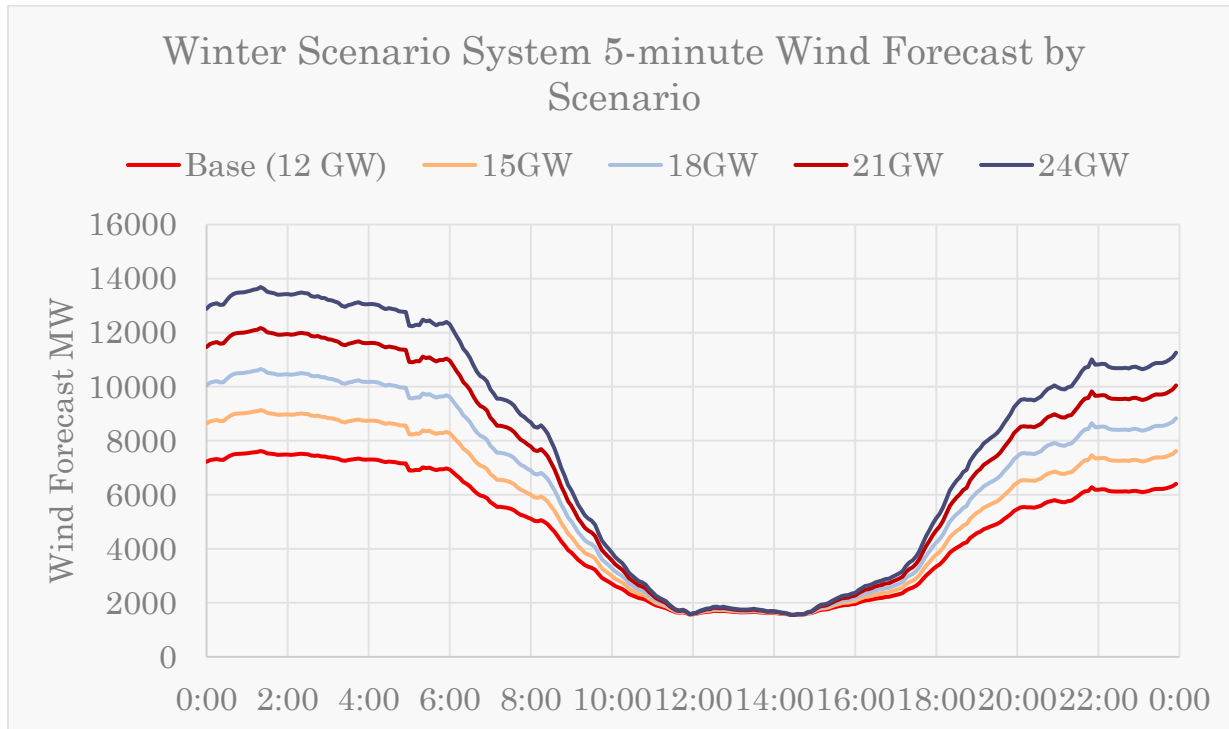

Spring scenario wind forecast chart; the 19:30 – 24:00 range is the focus of the 5-minute ramping analysis.

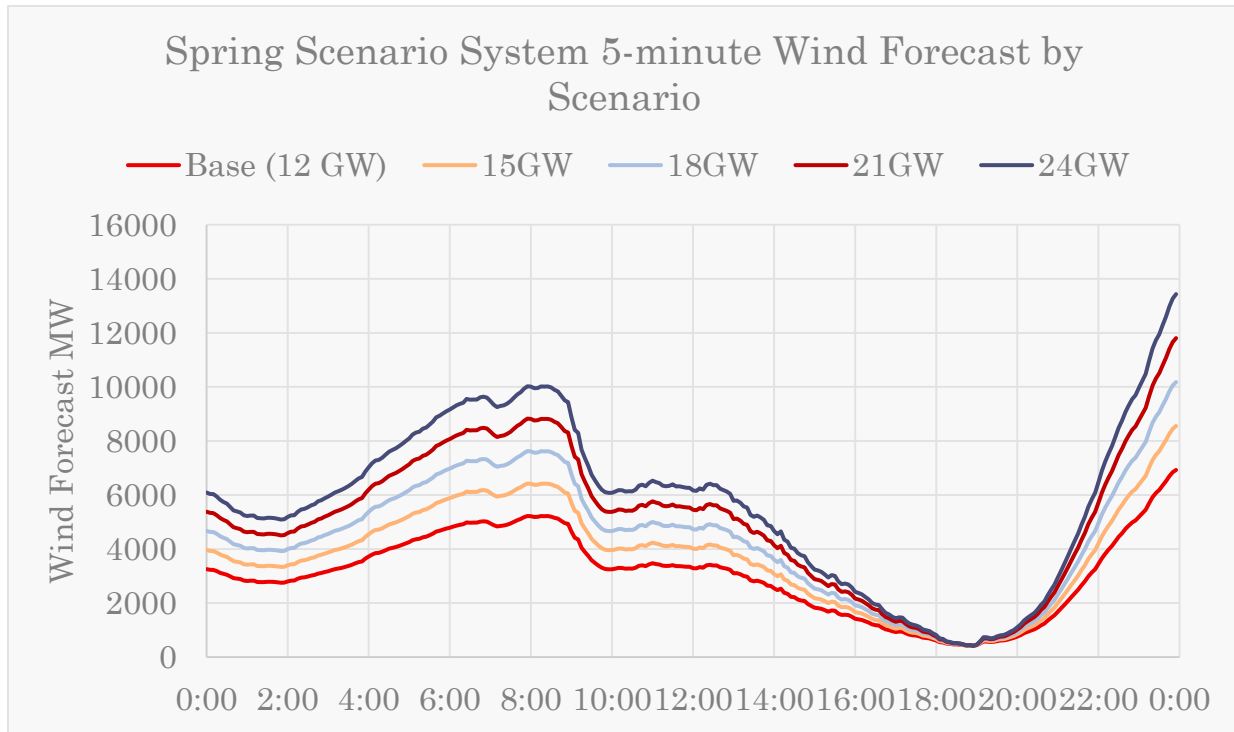

Summer scenario wind forecast chart; the 06:30 – 11:00 range is the focus of the 5-minute ramping analysis.

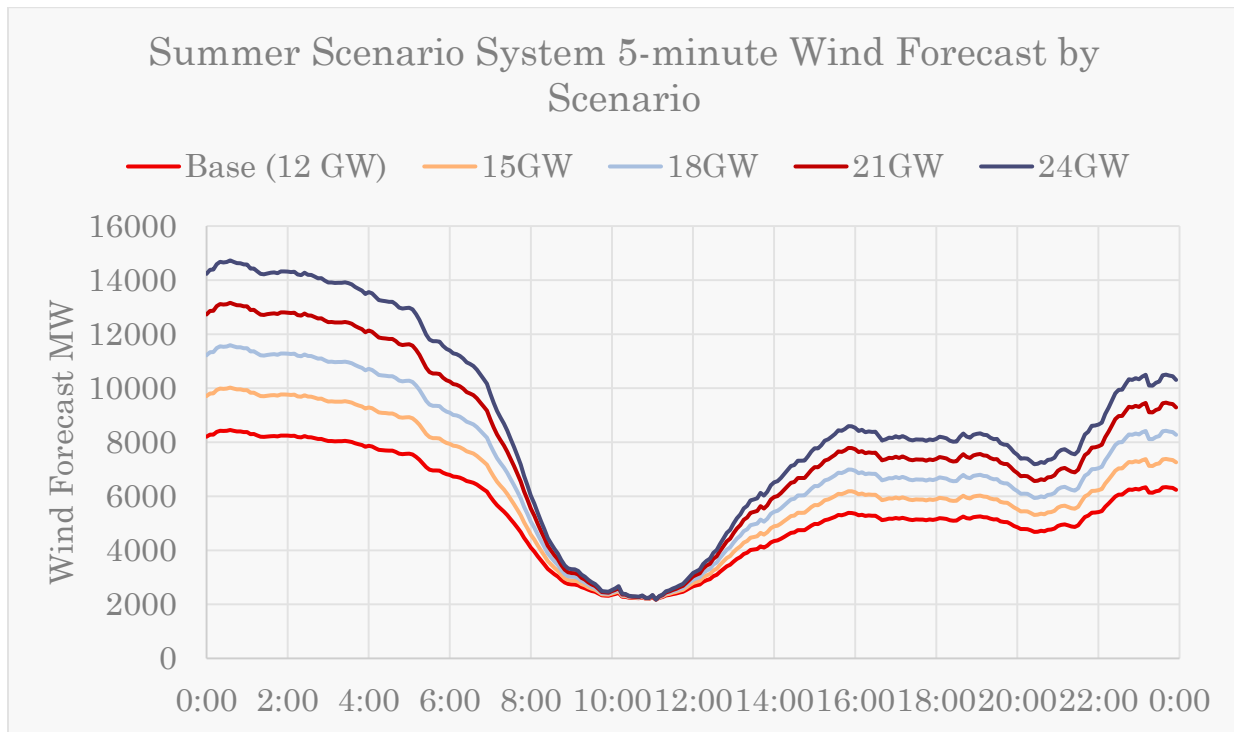

9.6 Other Scenario Modeling Information

9.6.1 Commitments, Start-ups, and Shut-downs

The commitments for each season/scenario were optimized over a seven day period to ensure that resources with longer start-up times and/or higher commitment costs were given a chance to become economic over a larger period than one day. Only operational nuclear units were Self-committed; the rest of the generation was allowed to be committed and dispatched economically to meet the load and variable generation obligations for each sub-scenario. No other generation was self-committed, though that has been a pattern in the current operation of the market. This would emulate changing market participant behavior to assess profitability over a longer time period at each incrementally higher penetration of variable generation.

Start-ups and shut-downs were assumed to be linear, with start-ups following the Sync-to-Min offer times, while shut-downs were simulated to occur at 30-minute min-to-off times (primarily to replicate the “staggering” of unit shut-downs that is typically done in real-time operations).

Commitment costs and parameters, energy offers, ramp rate capabilities, limits and unit statuses were taken from recently available market data. New resources (for which offer information was not available) adopted the same offer information as resources of the same fuel type and capacity that was geographically or electrically close to the new resource.

9.6.2 Transmission Constraints

Transmission constraints were assessed with the unit commitment and economic dispatch software, where in the initial phases of the study there was a multiple-step feedback process of running commitment and dispatch cases, running N-1 contingency analysis, and re-running the commitment and dispatch cases with the new constraints activated. About 5-10 of these constraints were discovered to be more localized, load pocket problems due to outages and/or load levels and would not benefit from redispatch, so these constraints were left out of the final commitment/dispatch runs. This left approximately 40 transmission constraints to be activated in the studies, being the most limiting monitored and contingent element pairings.

9.6.3 Ancillary Services and other Obligations

Contingency and Regulation reserves were required in the studies consistent with current methodologies. The Contingency Reserve obligations were based on the SPP Market/BA share of the loss of the single largest unit plus half of the next largest online unit. Regulation Up and Down reserve requirements were based on the existing methodology using four components:

- Load Magnitude component (0.8% of Load)
- Load Variability component (4% of hourly Load ramp)
- Intermittent Resource Magnitude Component (0.8% of wind/solar power magnitude)
- Intermittent Resource Variability Component (8% of hourly wind/solar ramp)

Regulation would only be cleared on “selected” resources, based on current operating practices. Selected resources were determined from the RUC studies, with selection high enough to cover 125% of the regulation requirements in either direction.

9.7 Scenario and Sub-Scenario Results

Overall, there were no ramp scarcity or emergency issues observed in each of the fifteen studied scenarios. However, multiple difficulties were observed in the 5-minute RTBM simulations due to the sharp and dramatic change in wind power.

9.7.1 Spring – Load Ramp Down, Wind Ramp Up

The Net Load ramping over the last 3 ½ hours for this set of scenarios spanned from about -8 GW in the base to -14 GW in the highest scenario. Down-ramp capability was the prime target here, and system prices, Regulation Down MCPs, and DVER redispatch were reflective of that.

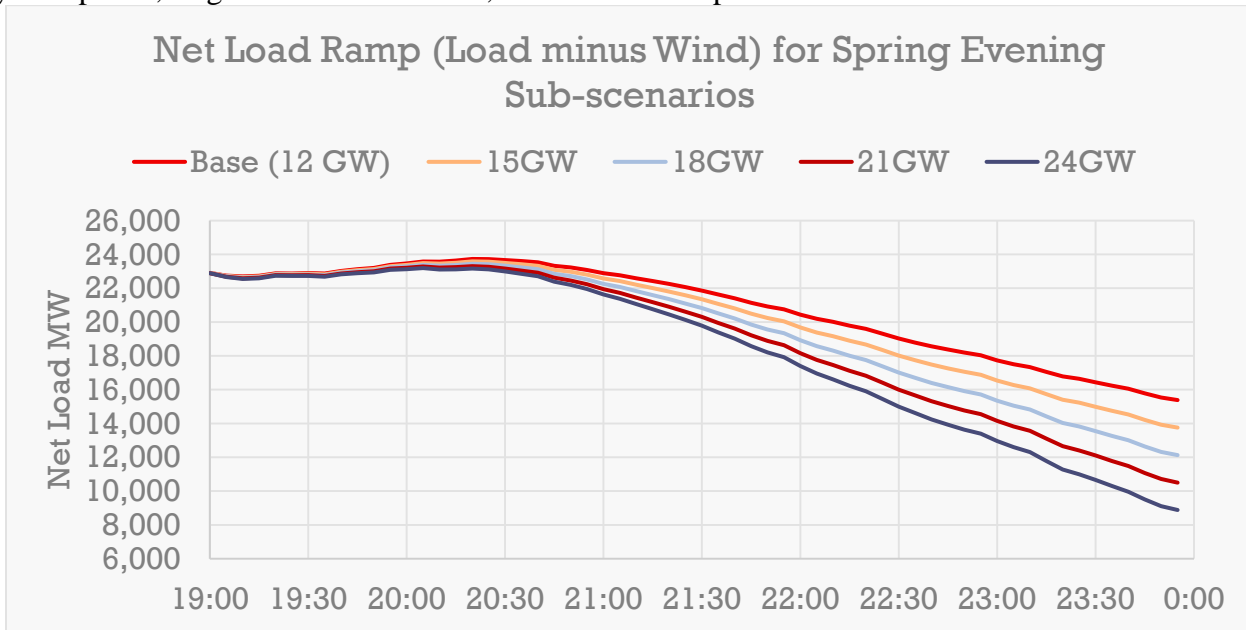

System pricing went to \$0 in the base scenario and further down past \$-30 in the higher wind sub-scenarios. The periodic rise in prices at the top of the hour was driven by two key factors: planned generation shut-downs and increased exports at the top of the hour. These two things contributed to relieve the down-ramping requirement on the rest of the system, temporarily raising prices.

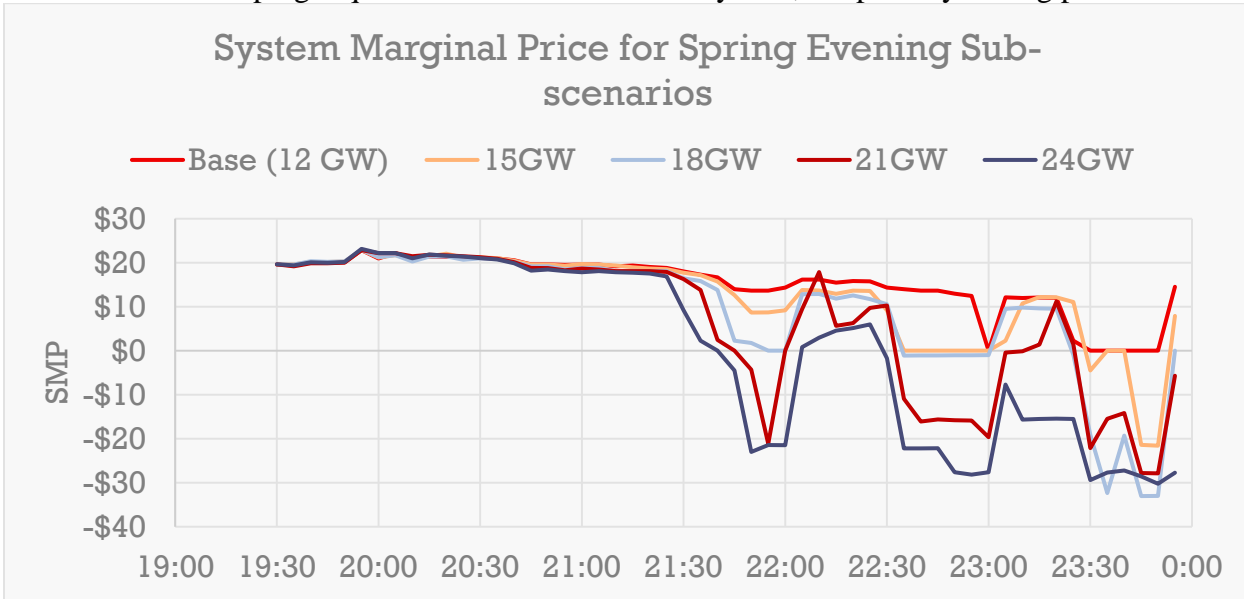

At the same time, Regulation Down marginal clearing prices (MCPs) saw an opposite rise, as the two services (energy and regulation down) were competing heavily for downward ramping capability. The system was still able to meet all reserve requirements and there was no scarcity.

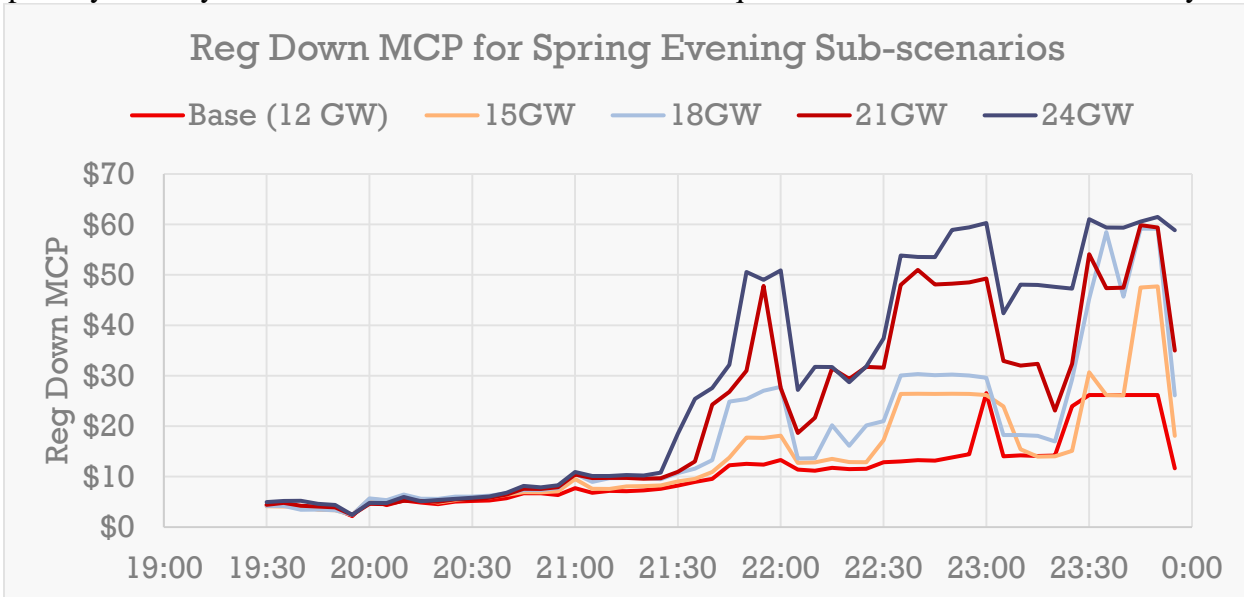

Because the magnitude and variability of the wind is an input to the reserve requirement process, this led to very large Regulation Down requirements, up to 600 MW in order to cover the 5-minute windows of ramping between RTBM solutions (at a time when load was in the 22-23 GW range). In this case, the Intermittent Resource variability and magnitude components contributed to the very high requirements for Reg Down, which in turn aggravated the ongoing down-ramp challenges to maintain energy balance.

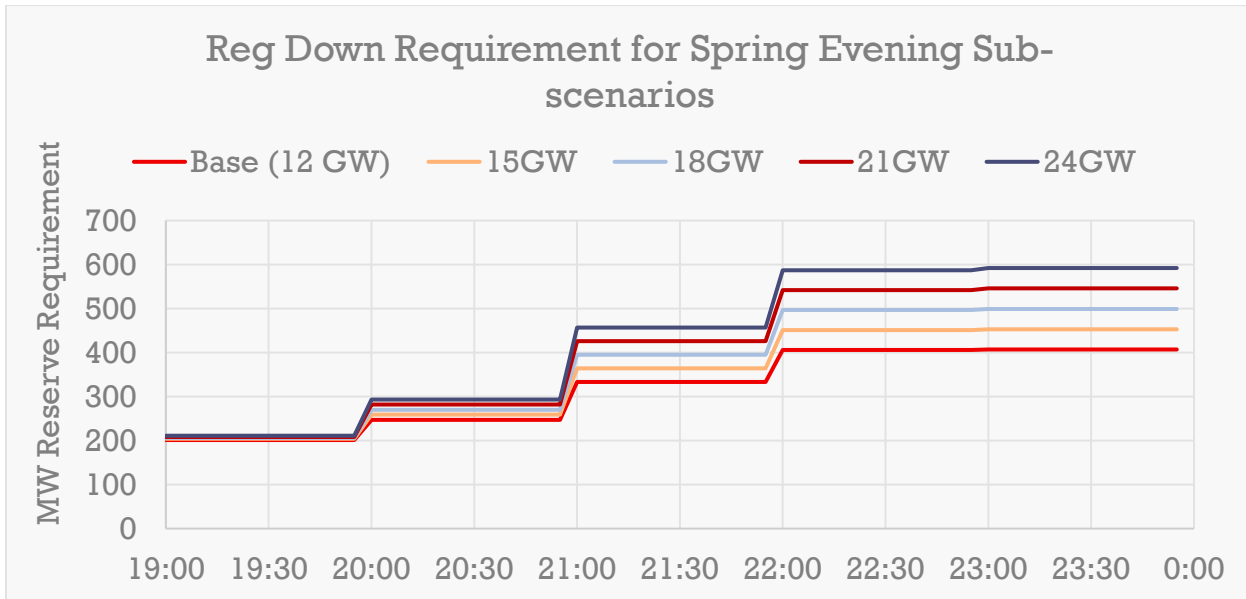

Congestion was noticeably higher in the highest wind scenarios, with more breached constraints as well. Most of the breaches were limited to one area in west Texas, where the low system prices were making it uneconomic to and difficult to increase generation in the area to push back on the constraint flows.

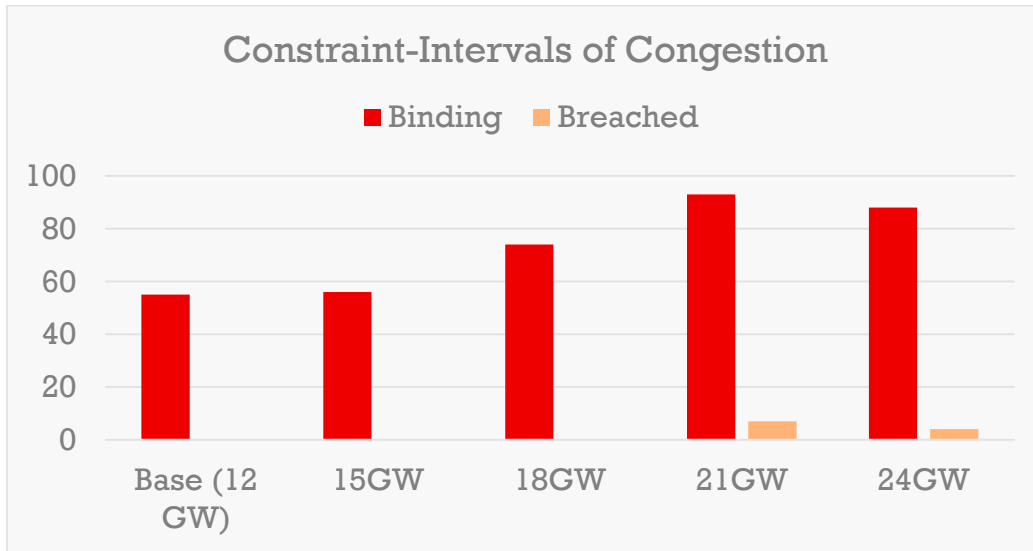

Redispatched wind and curtailments did not become prevalent until the last two hours of the scenarios, when the ramping was at its fastest and the system had already depleted some of its down-ramp capability. The 21 GW and 24 GW capacity scenarios showed up to 2.5 and 3.8 GW of curtailments, respectively.

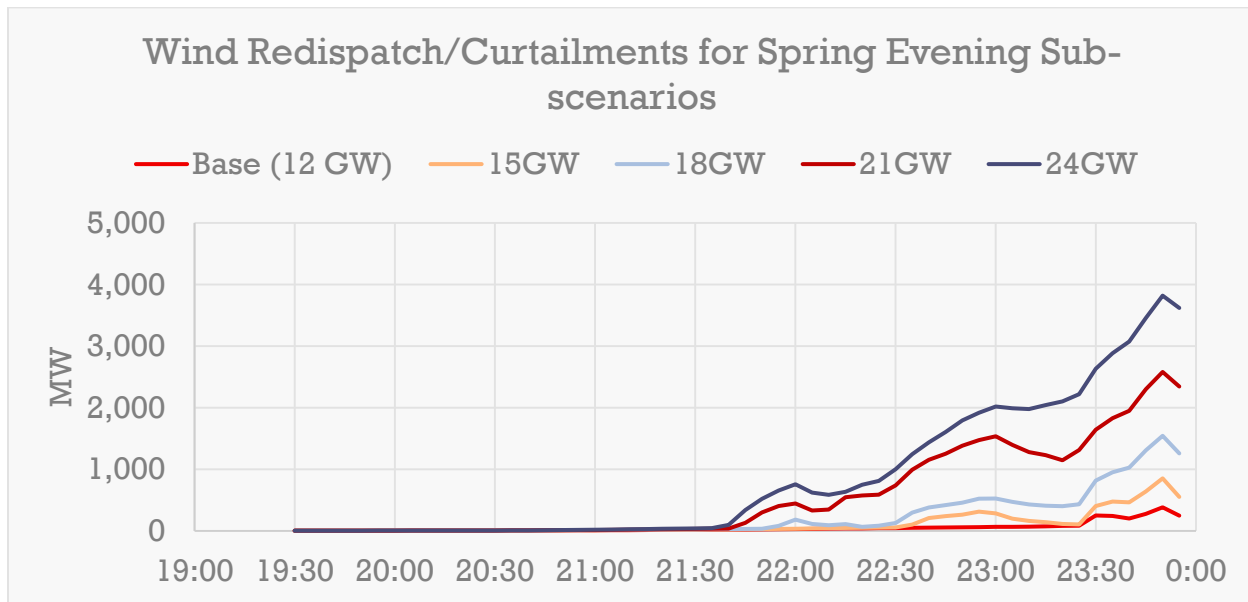

9.7.2 Winter – Morning Load Increase, Wind Ramp Down

The winter scenario was relatively mild during the sharpest portion of the ramping event, and was managed with stable prices for most of the middle and ending of the ramp. The window of study here was during the morning load ramp, while wind was dropping. The 06:00 – 07:15 span had the largest net load ramp, covering 5,000 MW at the base scenario and up to over 6,000 MW in the highest scenario.

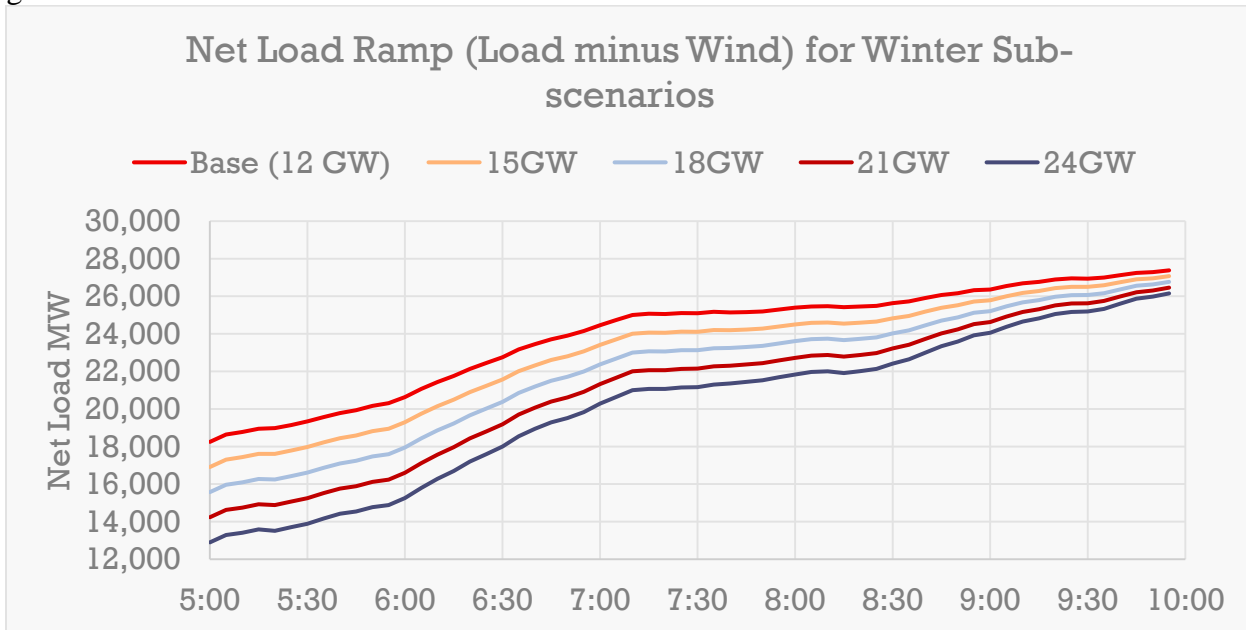

The major event for this scenario was the early portion the first few hours, where in the 05:00 – 06:00 range, there were heavy negative system prices in several of the sub-scenarios. Even though load was ramping up at the time and wind was dropping, there was enough capacity online in the scenario, as well as starting up, that the system had too much generation and prices went negative until the load ramp picked up faster after 06:00.

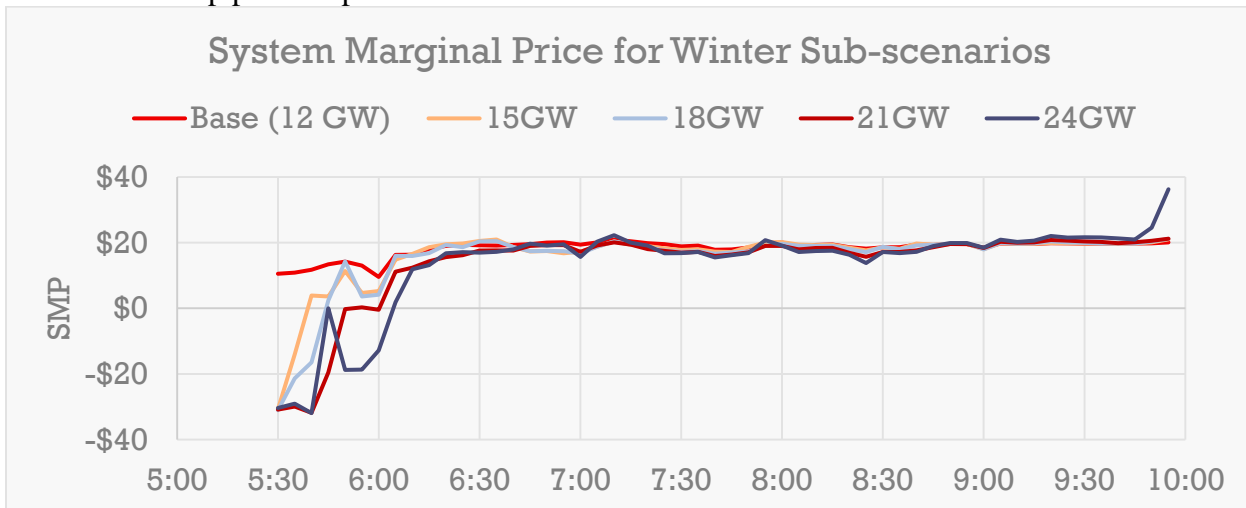

The problems can be seen more clearly when comparing the Base dispatch scenario to the final (#4) scenario. In the final scenario, there was a large amount (1.5 – 2.5 GW) of generation in start-up in the 05:00 – 07:00 span, which was committed in the studies to prepare for the bottoming out of the wind a few hours later. Since this scenario already had a large amount of wind at the start of the event, the system essentially had so much capacity that DVERs had to be curtailed (with low/negative prices) to maintain the generation/load balance. This can be seen in the charts below, where the total system Dispatch dips low enough to be in the DVER range.

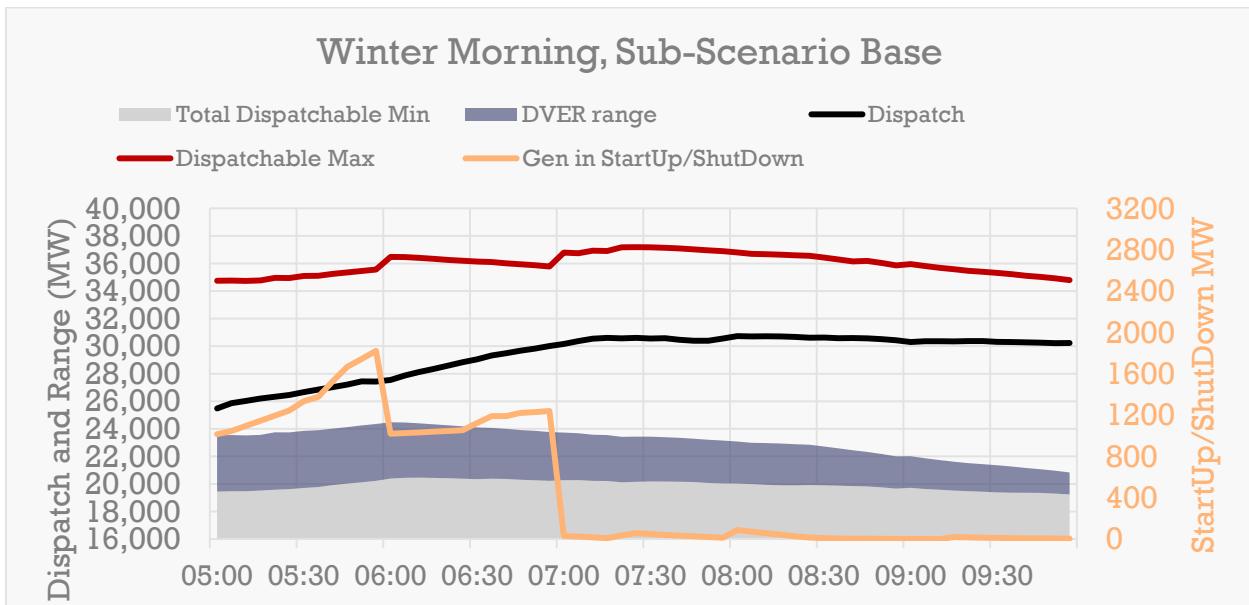
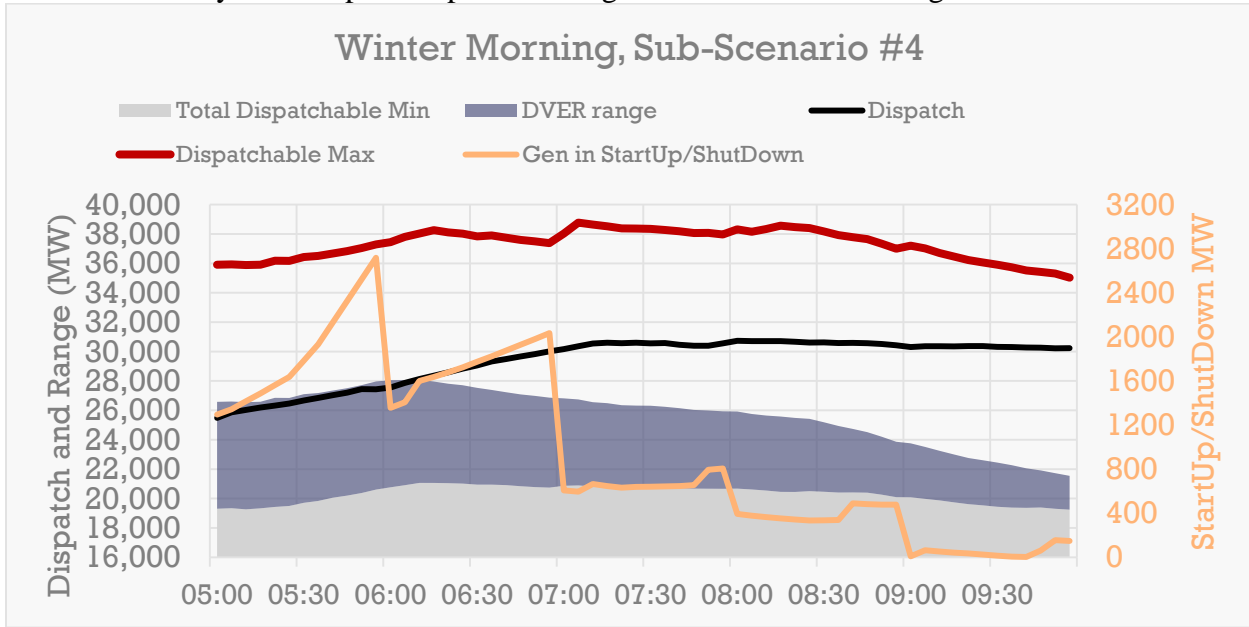

9.7.2 Summer – Load Ramp Up, Wind Ramp Down

The summer scenario showed no scarcity or ramping emergency conditions during the studied window. The net load ramp was at its worst in the 07:00 – 09:00 hours, and this corresponded to the largest typical wind power drops. The net load ramps during this two-hour time ranged from +8 GW in the base scenario to +12.3GW in the highest scenario.

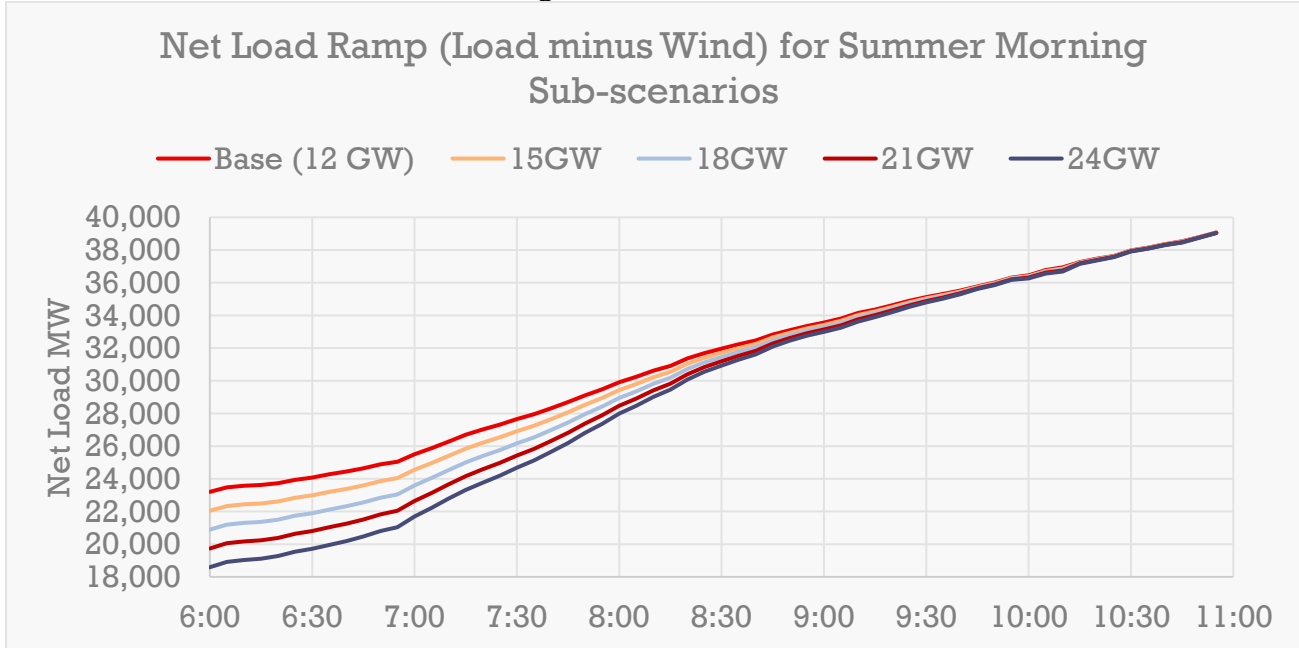

There were no scarcity or rampable capacity issues observed, primarily due to the amount of generation capacity that was already committed and online. The worst summer down-ramps of wind typically occur in early-mid morning hours, when load is not at peak and there is already sufficient capacity online to cover the load and wind for several more hours.

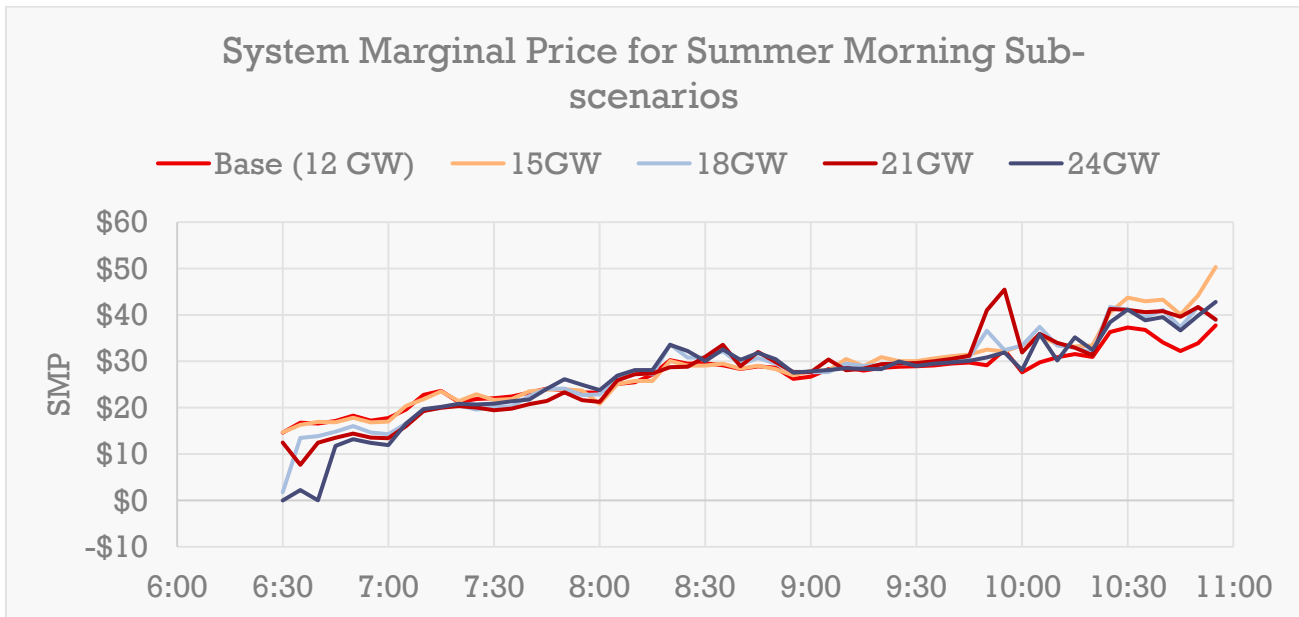

The summer scenarios also experienced similar issues to the winter scenarios, where there was a large amount of capacity online at the lowest load (especially in the highest wind scenarios). This helped make the ramp-up easier on the system, but also resulted in lower system prices in the 06:00-07:00 hour.

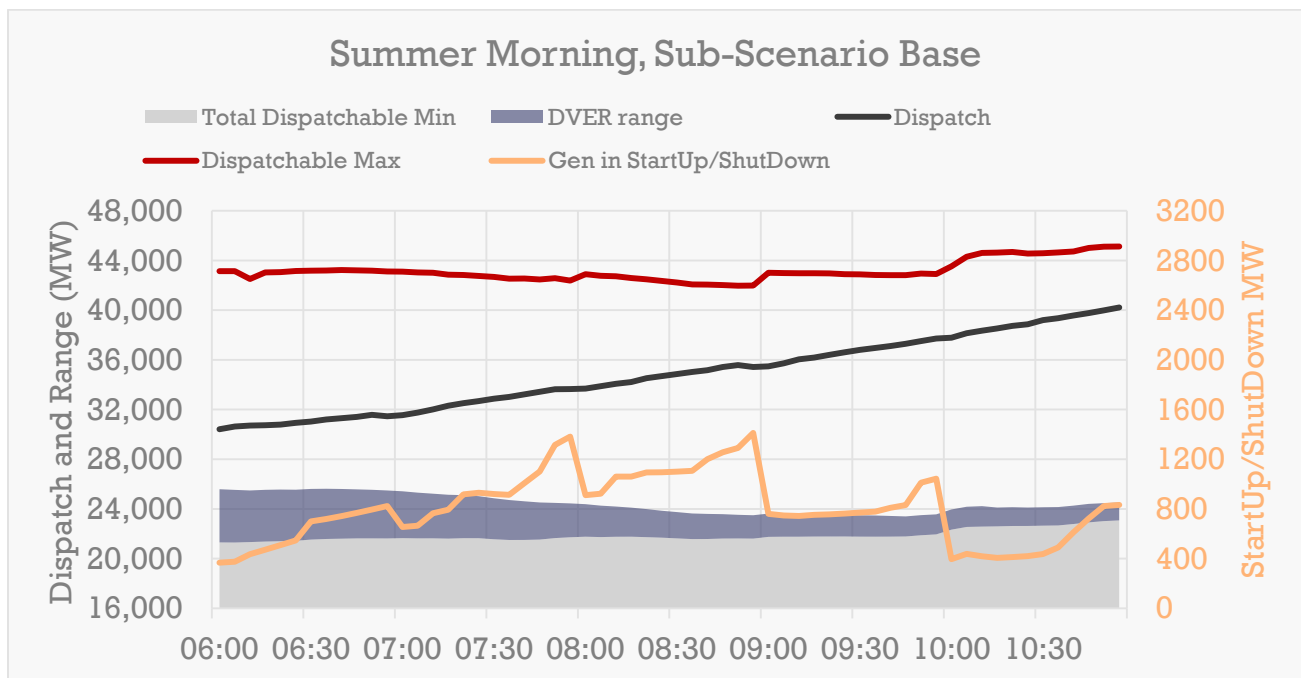
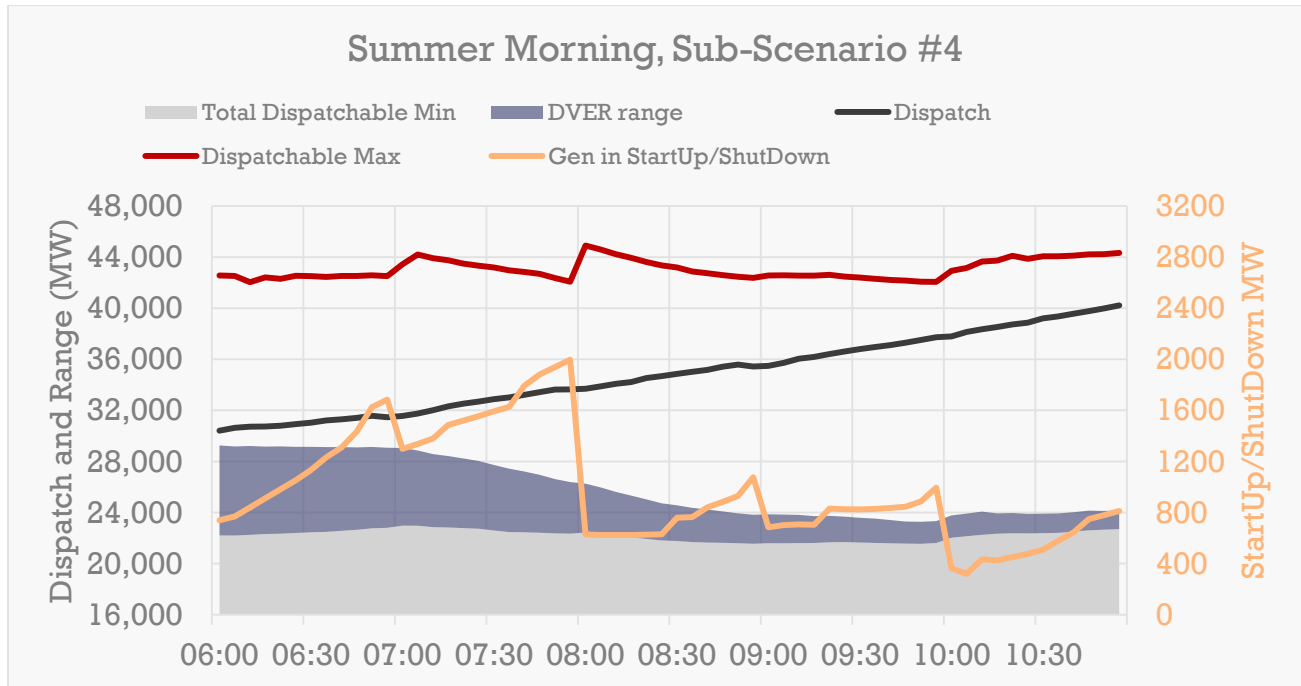

The higher wind ramps again contributed to very large regulation requirements, scraping over the 700 MW mark for the 08:00 hour. While there were no scarcity events for these scenarios, this increased requirement does put additional strain on the ramping requirements for the system.

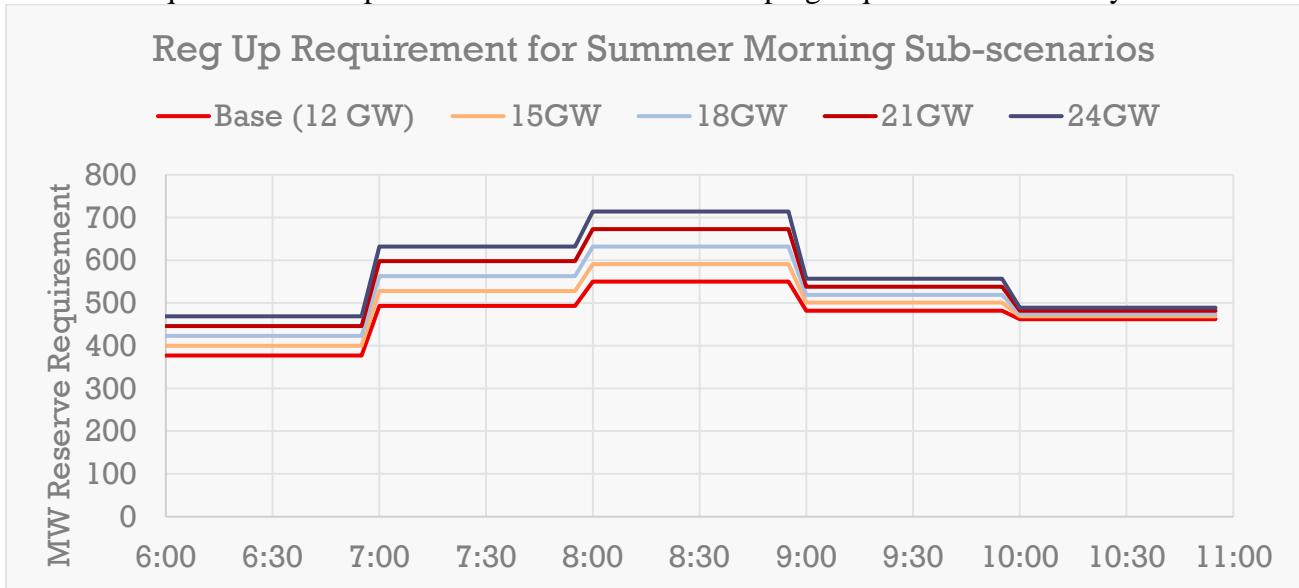

Congestion was actually slightly reduced during this window in the higher wind scenarios, though there were only small variations at the different ramping levels. This appeared to be mostly due to higher wind in the early hours supporting some constraints in west Texas, which eliminated a few additional binding/breached intervals.

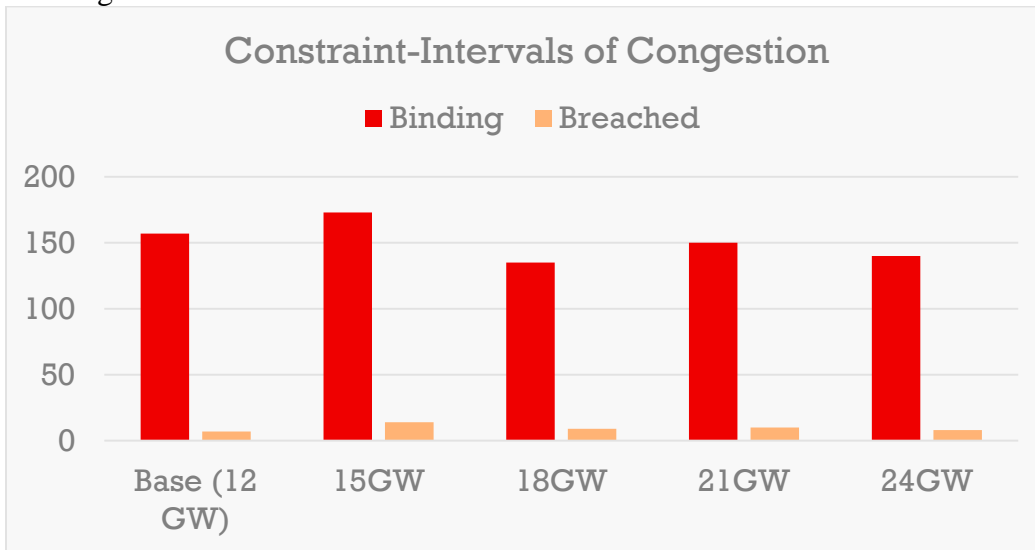

9.8 Summary

APPENDICES

1. Open Electrical: AC Power Transmission³

Introduction

Consider the following model depicting the transfer of AC power between two buses across a line, Figure 1.

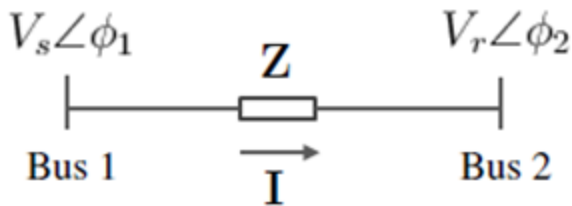

Figure 1. Simple AC power transmission model

Where $V_s = V_s e^{-j\phi_1}$ is the voltage and phase angle at the sending end

$V_r = V_r e^{-j\phi_2}$ is the voltage and phase angle at the receiving end

Z is the [complex impedance](#) of the line.

$$I = \frac{V_s - V_r}{Z} \text{ is the current phasor}$$

The [complex AC power](#) transmitted to the receiving end bus can be calculated as follows:

$$S = V_r I^*$$

At this stage, the impedance is purposely undefined and in the following sections, two different line impedance models will be introduced to illustrate the following fundamental features of AC power transmission:

- The power-angle relationship
- PV curves and steady-state voltage stability

Power-Angle Relationship

In its simplest form, we neglect the line resistance and capacitance and represent the line as purely inductive, i.e. $Z = j\omega L = jX$. The power transfer across the line is therefore:

$$\begin{aligned}
 S &= V_r \left[\frac{V_s - V_r}{jX} \right]^* \\
 &= \frac{V_r e^{-j\phi_2} (V_s e^{j\phi_1} - V_r e^{j\phi_2})}{-jX} \\
 &= j \frac{V_s V_r}{X} e^{-j(\phi_2 - \phi_1)} - j \frac{V_r^2}{X} \\
 &= \frac{V_s V_r}{X} \sin \delta + j \frac{V_r}{X} (V_s \cos \delta - V_r)
 \end{aligned}$$

Where $\delta = \phi_2 - \phi_1$ is called the power angle, which is the phase difference between the voltages on bus 1 and bus 2.

We can see that active and reactive power transfer can be characterized as follows:

$$\begin{aligned}
 P &= \frac{V_s V_r}{X} \sin \delta \\
 Q &= \frac{V_r}{X} (V_s \cos \delta - V_r)
 \end{aligned}$$

Plotting the active power transfer for various values of δ , we get, Figure 2:

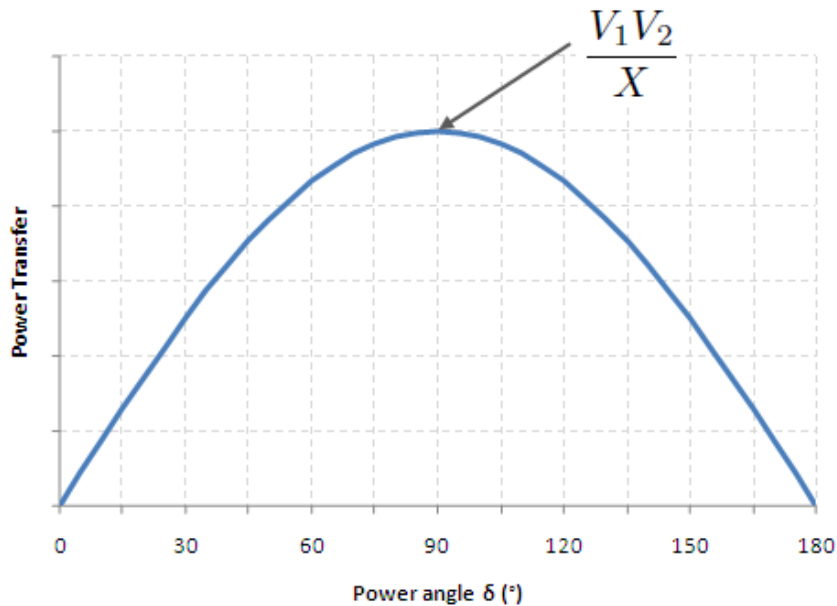

Figure 2. Active power transfer characteristic for a lossless line

The figure above is often used to articulate the **Power-Angle Relationship**. We can see that in this simple model, power will only flow when there is a phase difference between the voltages at the sending and receiving ends. Moreover, there is a theoretical limit to how much power can be transmitted through a line (shown here when the phase difference is 90°). This limit will be a

recurring theme in these line models, i.e. lines have natural capacity limits on how much power they can transmit.

Steady-State Voltage Stability Limits

The lossless (L) line model can be made more realistic by adding a resistive component, i.e.

$Z = R + jX = Ze^{j\theta}$. The power transfer across the line is therefore:

$$\begin{aligned} S &= V_r \left[\frac{V_s - V_r}{R + jX} \right]^* \\ &= \frac{V_r e^{-j\phi_2} (V_s e^{j\phi_1} - V_r e^{j\phi_2})}{Z e^{-j\theta}} \\ &= \frac{V_s V_r}{Z} e^{-j(\phi_2 - \phi_1 - \theta)} - \frac{V_r^2}{Z} e^{j\theta} \end{aligned}$$

From the above equation, the active and reactive power transfer can be shown to be:

$$\begin{aligned} P &= \frac{V_s V_r}{Z} \cos(\delta - \theta) - \frac{V_r^2}{Z} \cos \theta \\ Q &= -\frac{V_s V_r}{Z} \sin(\delta - \theta) - \frac{V_r^2}{Z} \sin \theta \end{aligned}$$

From the active power equation, we can solve for the voltage at bus 2 using the quadratic equation, i.e.:

$$V_r = \frac{-b \pm \sqrt{b^2 - 4ac}}{2a},$$

Where $a = \frac{\cos \theta}{Z}$

$$\begin{aligned} b &= \frac{V_s}{Z} \cos(\delta - \theta) \\ c &= -P \end{aligned}$$

By keeping the voltage at bus 1, power angle and line impedance constant, we can plot the effect of increasing the active power on the voltage at bus 2 on a PV curve, Figure 3.

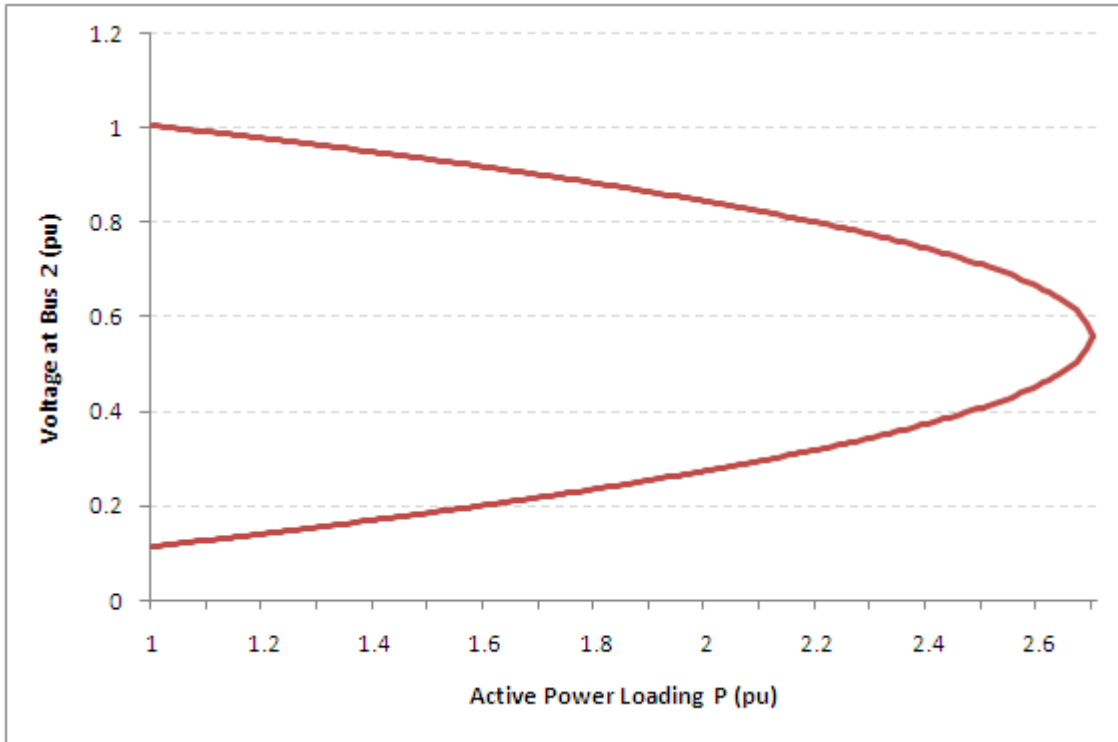

Figure 3. PV Curve at Bus 2 for a RL line

The PV curve shows that the voltage at bus 2 falls as the active power loading increases. The voltage falls until it hits a critical point (around 2.7pu loading) where the quadratic equation is no longer solvable. This is referred to as the "nose point" or "point of voltage collapse", and is the theoretical steady-state stability limit of the line.

BEPC Comments

BEPC Comments	Case Type	Bus Name	Transmission Owner Bus	Area Name	V (p.u.)	Criteria	Contingency	Transmission Owner Branch
Non-BES Exclusion E1.	Load Pocket	BLUEBUTE-MK7115.	McKenzie Electric Cooperative	WAPA	0.8479	0.9	BEARCREK-MK7115. - ROUNDUP 7115.	McKenzie Electric & BEPC
Non-BES Exclusion E1.	Load Pocket	GRAIL -MK7115.	McKenzie Electric Cooperative	WAPA	0.8484	0.9		
Non-BES Exclusion E1.	Load Pocket	MOCCASIN-MK7115.	McKenzie Electric Cooperative	WAPA	0.849	0.9		
Non-BES Exclusion E1.	Load Pocket	J12 -MK7115.	McKenzie Electric Cooperative	WAPA	0.8502	0.9		
Non-BES Exclusion E1.	Load Pocket	L11BGGUL-MK7115.	McKenzie Electric Cooperative	WAPA	0.8564	0.9		
Non-BES Exclusion E1.	Load Pocket	MOUNTAIN-MK7115.	McKenzie Electric Cooperative	WAPA	0.8597	0.9	BEARCREK-MK7115. - ROUNDUP 7115.	McKenzie Electric & BEPC
Manual check, voltage OK for N-1. (Appears like results from N-2)	Load Pocket	BEARCREK-MK7115.	McKenzie Electric Cooperative	WAPA	0.8645	0.9		
Manual check, voltage OK for N-1. (Appears like results from N-2)	Load Pocket	OAKDALE - MK7115.	McKenzie Electric Cooperative	WAPA	0.8667	0.9		
Non-BES Exclusion E3.	Load Pocket	RUTHVILL-CP7115.	Central Power Electric Cooperative	WAPA	0.8723	0.9	MALLARD7 115. - RUTHVILL-CP7115.	Central Power & NSP (XCEL)
Manual check, voltage OK for N-1. (Appears like results from N-2)	Load Pocket	KILLDEER-MK7115.	McKenzie Electric Cooperative	WAPA	0.879	0.9	BEARCREK-MK7115. - ROUNDUP 7115.	McKenzie Electric & BEPC
Manual check, voltage OK for N-1. (Appears like results from N-2)	Load Pocket	KILDEER7 115.	WAPA-UGPR	WAPA	0.8802	0.9		
Parshall Area UVLS installed. See Op Guide.	Load Pocket	RBNSNLAK-MW7115.	Mountrail Williams Electric Cooperative	WAPA	0.8855	0.9	BELDEN -MW7115. - RBNSNLAK-MW7115.	Mountrail Williams Electric Cooperative
Parshall Area UVLS	Load	FINSTAD -	Mountrail	WAPA	0.8882	0.9		

installed. See Op Guide.	Pocket	MW7115.	Williams Electric Cooperative					
Parshall Area UVLS installed. See Op Guide.	Load Pocket	OSBORN - MW7115.	Mountrail Williams Electric Cooperative	WAPA	0.8905	0.9		
Parshall Area UVLS installed. See Op Guide.	Load Pocket	BIGBEND - MW7115.	Mountrail Williams Electric Cooperative	WAPA	0.8909	0.9		
Parshall Area UVLS installed. See Op Guide.	Load Pocket	ENEWTWN - MW7115.	Mountrail Williams Electric Cooperative	WAPA	0.8913	0.9		
Parshall Area UVLS installed. See Op Guide.	Load Pocket	VANHOOK - MW7115.	Mountrail Williams Electric Cooperative	WAPA	0.8937	0.9	BELDEN -MW7115. - RBNSNLAK- MW7115.	Mountrail Williams Electric Cooperative
Non-BES Exclusion E3.	Load Pocket	DUNNING7- CP7115.	Central Power Electric Cooperative	WAPA	0.8942	0.9	MALLARD7 115. - RUTHVILL-CP7115.	Central Power & NSP (XCEL)
Parshall Area UVLS installed. See Op Guide.	Load Pocket	PARSHALL- MW7115.	Mountrail Williams Electric Cooperative	WAPA	0.8974	0.9	BELDEN -MW7115. - RBNSNLAK- MW7115.	Mountrail Williams Electric Cooperative
Bus ' ANTELOP-LNX3345 ' should also be disconnected with this contingency.	Load Pocket	ANTELOP- LNX3345.	BEPC	WAPA	1.1143	1.05	ANTELOP3 345. - ANTELOP- LNX3345.	BEPC
Lock shunt at bus 652490. Will yield <1.10 HV criterion.	Load Pocket	PHILIP 4 230.	BEPC	WAPA	1.1026	1.05	PHILIP 4 230. - PHILTAP4 230.	BEPC
Bus ' LELAND2-LNX3345 ' should also be disconnected with this contingency.	Load Pocket	LELAND2- LNX3345.	BEPC	WAPA	1.1019	1.05	LELANDO3 345. - LELAND2-LNX3345.	BEPC
<1.10 HV criterion.	Load Pocket	WANBLEE 7 115.	Future (WAPA-UGPR?)	WAPA	~1.0857	1.05	"Violation For 3750 Contingencies"	Many contingencies with many owners.
Non-BES Exclusion E3.	2017 45%	RUTHVILL-CP7115.	Central Power	WAPA	0.868	0.9	MALLARD7 115. -	Central Power &

	without outages		Electric Cooperative				RUTHVILL-CP7115.	NSP (XCEL)
Bus ' ANTELOP-LNX3345 ' should also be disconnected with this contingency.	2017 45% without outages	ANTELOP-LNX3345.	BEPC	WAPA	1.118	1.05	ANTELOP3 345. - ANTELOP-LNX3345.	BEPC
Bus ' LELAND2-LNX3345 ' should also be disconnected with this contingency.	2017 45% without outages	LELAND2-LNX3345.	BEPC	WAPA	1.103	1.05	LELANDO3 345. - LELAND2-LNX3345.	BEPC
Non-BES Exclusion E3.	2021 60% without outages	RUTHVILL-CP7115.	Central Power Electric Cooperative	WAPA	0.814	0.9	MALLARD7 115. - RUTHVILL-CP7115.	Central Power & NSP (XCEL)
Non-BES Exclusion E3.	2021 60% without outages	DUNNING7-CP7115.	Central Power Electric Cooperative	WAPA	0.841	0.9		No contingent branch stated.
Non-BES Exclusion E3.	2021 60% without outages	HARAM -CP7115.	Central Power Electric Cooperative	WAPA	0.872	0.9		No contingent branch stated.
Non-BES Exclusion E3.	2021 60% without outages	WSTBOTJC-CP7115.	Central Power Electric Cooperative	WAPA	0.872	0.9	MALLARD7 115. - RUTHVILL-CP7115.	Central Power & NSP (XCEL)
Non-BES Exclusion E3.	2021 60% without outages	BOTTNO 7 115.	Central Power Electric Cooperative	WAPA	0.882	0.9		No contingent branch stated.
Non-BES Exclusion E3.	2021 60% without outages	BOTNO_SE-CP7115.	Central Power Electric Cooperative	WAPA	0.882	0.9		No contingent branch stated.
Bus ' ANTELOP-LNX3345 ' should also be disconnected with this contingency.	2021 60% without outages	ANTELOP-LNX3345.	BEPC	WAPA	1.123	1.05	ANTELOP3 345. - ANTELOP-LNX3345.	BEPC
Bus ' LELAND2-LNX3345 ' should also be disconnected with this	2021 60% without outages	LELAND2-LNX3345.	BEPC	WAPA	1.101	1.05	LELANDO3 345. - LELAND2-LNX3345.	BEPC

contingency.								
Non-BES Exclusion E3.	2017 45% with outages	RUTHVILL-CP7115.	Central Power Electric Cooperative	WAPA	0.815	0.9	MALLARD7 115. - RUTHVILL-CP7115.	Central Power & NSP (XCEL)
Non-BES Exclusion E1.	2017 45% with outages	BLUEBUTE-MK7115.	McKenzie Electric Cooperative	WAPA	0.821	0.9	BEARCREK-MK7115. - ROUNDUP 7115.	McKenzie Electric & BEPC
Non-BES Exclusion E1.	2017 45% with outages	GRAIL -MK7115.	McKenzie Electric Cooperative	WAPA	0.822	0.9	BEARCREK-MK7115. - ROUNDUP 7115.	McKenzie Electric & BEPC
Non-BES Exclusion E1.	2017 45% with outages	MOCCASIN-MK7115.	McKenzie Electric Cooperative	WAPA	0.823	0.9	BEARCREK-MK7115. - ROUNDUP 7115.	McKenzie Electric & BEPC
Non-BES Exclusion E1.	2017 45% with outages	J12 -MK7115.	McKenzie Electric Cooperative	WAPA	0.824	0.9	BEARCREK-MK7115. - ROUNDUP 7115.	McKenzie Electric & BEPC
Non-BES Exclusion E1.	2017 45% with outages	L11BGGUL-MK7115.	McKenzie Electric Cooperative	WAPA	0.83	0.9	BEARCREK-MK7115. - ROUNDUP 7115.	McKenzie Electric & BEPC
Non-BES Exclusion E1.	2017 45% with outages	MOUNTAIN-MK7115.	McKenzie Electric Cooperative	WAPA	0.834	0.9	BEARCREK-MK7115. - ROUNDUP 7115.	McKenzie Electric & BEPC
Manual check, voltage OK for N-1. (Appears like results from N-2)	2017 45% with outages	BEARCREK-MK7115.	McKenzie Electric Cooperative	WAPA	0.84	0.9	BEARCREK-MK7115. - ROUNDUP 7115.	McKenzie Electric & BEPC
Manual check, voltage OK for N-1. (Appears like results from N-2)	2017 45% with outages	OAKDALE -MK7115.	McKenzie Electric Cooperative	WAPA	0.842	0.9	BEARCREK-MK7115. - ROUNDUP 7115.	McKenzie Electric & BEPC
Non-BES Exclusion E3.	2017 45% with outages	DUNNING7-CP7115.	Central Power Electric Cooperative	WAPA	0.842	0.9	MALLARD7 115. - RUTHVILL-CP7115.	Central Power & NSP (XCEL)
Manual check, voltage OK for N-1. (Appears like results from N-2)	2017 45% with outages	KILLDEER-MK7115.	McKenzie Electric Cooperative	WAPA	0.856	0.9	BEARCREK-MK7115. - ROUNDUP 7115.	McKenzie Electric & BEPC
Manual check, voltage	2017 45%	KILDEER7 115.	WAPA-UGPR	WAPA	0.857	0.9	BEARCREK-	McKenzie Electric

OK for N-1. (Appears like results from N-2)	with outages						MK7115. - ROUNDUP 7115.	& BEPC
Non-BES Exclusion E3.	2017 45% with outages	HARAM -CP7115.	Central Power Electric Cooperative	WAPA	0.873	0.9	MALLARD7 115. - RUTHVILL-CP7115.	Central Power & NSP (XCEL)
Non-BES Exclusion E3.	2017 45% with outages	WSTBOTJC-CP7115.	Central Power Electric Cooperative	WAPA	0.873	0.9	MALLARD7 115. - RUTHVILL-CP7115.	Central Power & NSP (XCEL)
Non-BES Exclusion E3.	2017 45% with outages	BOTTNO 7 115.	Central Power Electric Cooperative	WAPA	0.882	0.9	MALLARD7 115. - RUTHVILL-CP7115.	Central Power & NSP (XCEL)
Non-BES Exclusion E3.	2017 45% with outages	BOTNO_SE-CP7115.	Central Power Electric Cooperative	WAPA	0.883	0.9	MALLARD7 115. - RUTHVILL-CP7115.	Central Power & NSP (XCEL)
Bus ' ANTELOP-LNX3345 ' should also be disconnected with this contingency.	2017 45% with outages	ANTELOP-LNX3345.	BEPC	WAPA	1.118	1.05	ANTELOP3 345. - ANTELOP-LNX3345.	BEPC
Bus ' LELAND2-LNX3345 ' should also be disconnected with this contingency.	2017 45% with outages	LELAND2-LNX3345.	BEPC	WAPA	1.101	1.05	LELANDO3 345. - LELAND2-LNX3345.	BEPC
<1.10 HV criterion.	2017 45% with outages	PHILIP 7 115.	WAPA-UGPR	WAPA	1.097	1.05	PHILIP 4 230. - PHILTAP4 230.	BEPC
<1.10 HV criterion.	2017 45% with outages	PHILIP 4 230.	BEPC	WAPA	1.097	1.05	PHILIP 4 230. - PHILTAP4 230.	BEPC
<1.10 HV criterion.	2017 45% with outages	SHAN-SD7 115.	LaCreek Electric Cooperative	WAPA	1.085	1.05	GORDON 7 115. - RUSHVIL7 115.	NPPD
<1.10 HV criterion.	2017 45% with outages	SHAN-SD7 115.	LaCreek Electric Cooperative	WAPA	1.082	1.05	CHADRON7 115. - RUSHVIL7 115.	NPPD
	2017 45%	MOORHED7 115.	City of Moorhead	WAPA	1.081	1.05	SHEYNNE4 230. -	WAPA-UGPR &

	with outages						FARGO 4 230.	NSP(XCEL)
Non-BES Exclusion E3.	2021 45% without outages	RUTHVILL-CP7115.	Central Power Electric Cooperative	WAPA	0.868	0.9	MALLARD7 115. - RUTHVILL-CP7115.	Central Power & NSP (XCEL)
Bus ' ANTELOP-LNX3345 ' should also be disconnected with this contingency.	2021 45% without outages	ANTELOP-LNX3345.	BEPC	WAPA	1.118	1.05	ANTELOP3 345. - ANTELOP-LNX3345.	BEPC
Bus ' LELAND2-LNX3345 ' should also be disconnected with this contingency.	2021 45% without outages	LELAND2-LNX3345.	BEPC	WAPA	1.103	1.05	LELANDO3 345. - LELAND2-LNX3345.	BEPC
Non-BES Exclusion E3.	2021 45% with outages	RUTHVILL-CP7115.	Central Power Electric Cooperative	WAPA	0.815	0.9	MALLARD7 115. - RUTHVILL-CP7115.	Central Power & NSP (XCEL)
Non-BES Exclusion E1.	2021 45% with outages	BLUEBUTE-MK7115.	McKenzie Electric Cooperative	WAPA	0.821	0.9	BEARCREK-MK7115. - ROUNDUP 7115.	McKenzie Electric & BEPC
Non-BES Exclusion E1.	2021 45% with outages	GRAIL -MK7115.	McKenzie Electric Cooperative	WAPA	0.822	0.9	BEARCREK-MK7115. - ROUNDUP 7115.	McKenzie Electric & BEPC
Non-BES Exclusion E1.	2021 45% with outages	MOCCASIN-MK7115.	McKenzie Electric Cooperative	WAPA	0.823	0.9	BEARCREK-MK7115. - ROUNDUP 7115.	McKenzie Electric & BEPC
Non-BES Exclusion E1.	2021 45% with outages	J12 -MK7115.	McKenzie Electric Cooperative	WAPA	0.824	0.9	BEARCREK-MK7115. - ROUNDUP 7115.	McKenzie Electric & BEPC
Non-BES Exclusion E1.	2021 45% with outages	L11BGGUL-MK7115.	McKenzie Electric Cooperative	WAPA	0.83	0.9	BEARCREK-MK7115. - ROUNDUP 7115.	McKenzie Electric & BEPC
Non-BES Exclusion E1.	2021 45% with outages	MOUNTAIN-MK7115.	McKenzie Electric Cooperative	WAPA	0.834	0.9	BEARCREK-MK7115. - ROUNDUP 7115.	McKenzie Electric & BEPC
Manual check, voltage	2021 45%	BEARCREK-	McKenzie Electric	WAPA	0.84	0.9	BEARCREK-	McKenzie Electric

Southwest Power Pool, Inc. Powertech Labs Inc.

OK for N-1. (Appears like results from N-2)	with outages	MK7115.	Cooperative				MK7115. - ROUNDUP 7115.	& BEPC
Manual check, voltage OK for N-1. (Appears like results from N-2)	2021 45% with outages	OAKDALE - MK7115.	McKenzie Electric Cooperative	WAPA	0.842	0.9	BEARCREK- MK7115. - ROUNDUP 7115.	McKenzie Electric & BEPC
Non-BES Exclusion E3.	2021 45% with outages	DUNNING7- CP7115.	Central Power Electric Cooperative	WAPA	0.842	0.9	MALLARD7 115. - RUTHVILL-CP7115.	Central Power & NSP (XCEL)
Manual check, voltage OK for N-1. (Appears like results from N-2)	2021 45% with outages	KILLDEER- MK7115.	McKenzie Electric Cooperative	WAPA	0.856	0.9	BEARCREK- MK7115. - ROUNDUP 7115.	McKenzie Electric & BEPC
Manual check, voltage OK for N-1. (Appears like results from N-2)	2021 45% with outages	KILDEER7 115.	WAPA-UGPR	WAPA	0.857	0.9	BEARCREK- MK7115. - ROUNDUP 7115.	McKenzie Electric & BEPC
Non-BES Exclusion E3.	2021 45% with outages	HARAM -CP7115.	Central Power Electric Cooperative	WAPA	0.873	0.9	MALLARD7 115. - RUTHVILL-CP7115.	Central Power & NSP (XCEL)
Non-BES Exclusion E3.	2021 45% with outages	WSTBOTJC- CP7115.	Central Power Electric Cooperative	WAPA	0.873	0.9	MALLARD7 115. - RUTHVILL-CP7115.	Central Power & NSP (XCEL)
Non-BES Exclusion E3.	2021 45% with outages	BOTTNO 7 115.	Central Power Electric Cooperative	WAPA	0.882	0.9	MALLARD7 115. - RUTHVILL-CP7115.	Central Power & NSP (XCEL)
Non-BES Exclusion E3.	2021 45% with outages	BOTNO_SE- CP7115.	Central Power Electric Cooperative	WAPA	0.883	0.9	MALLARD7 115. - RUTHVILL-CP7115.	Central Power & NSP (XCEL)
Bus ' ANTELOP-LNX3345 ' should also be disconnected with this contingency.	2021 45% with outages	ANTELOP- LNX3345.	BEPC	WAPA	1.118	1.05	ANTELOP3 345. - ANTELOP- LNX3345.	BEPC
Bus ' LELAND2-LNX3345 ' should also be disconnected with this contingency.	2021 45% with outages	LELAND2- LNX3345.	BEPC	WAPA	1.101	1.05	LELANDO3 345. - LELAND2-LNX3345.	BEPC
<1.10 HV criterion.	2021 45%	PHILIP 7 115.	WAPA-UGPR	WAPA	1.097	1.05	PHILIP 4 230. -	BEPC

Southwest Power Pool, Inc. Powertech Labs Inc.

	with outages						PHILTAP4 230.	
<1.10 HV criterion.	2021 45% with outages	PHILIP 4 230.	BEPC	WAPA	1.097	1.05	PHILIP 4 230. - PHILTAP4 230.	BEPC
<1.10 HV criterion.	2021 45% with outages	SHAN-SD7 115.	LaCreek Electric Cooperative	WAPA	1.085	1.05	GORDON 7 115. - RUSHVIL7 115.	NPPD
<1.10 HV criterion.	2021 45% with outages	SHAN-SD7 115.	LaCreek Electric Cooperative	WAPA	1.082	1.05	CHADRON7 115. - RUSHVIL7 115.	NPPD
	2021 45% with outages	MOORHED7 115.	City of Moorhead	WAPA	1.081	1.05	SHEYNNE4 230. - FARGO 4 230.	WAPA-UGPR & NSP(XCEL)

REFERENCES

- [1] [NERC, Bulk Electric System Definition Reference Document](#), version 2, April 2014, page 3.
- [2] Electric Power Research Institute, “EPRI Power system Dynamics Tutorial”, EPRI, Palo Alto, CA. 2009. 1016042, available at www.epri.com, Section 5.6.4, pages 5-57 and 5-58.
- [3] Ibid, 2, Section 6.2.2, page 6-2.
- [4] Ibid, 2, Section 6.2.1, page 6-1.
- [5] Powertech Labs, Inc., Dynamic Security Assessment Software (DSATools), [Voltage Security Assessment Tool \(VSAT\)](#).
- [6] Ibid, 2, Section 6.9.2, page 6-41.
- [7] Ibid, 2, Section 6.4.3, pages 6-6 through 6-7.
- [8] Ibid, 2, Section 6.4.3, pages 6-6 through 6-7.
- [9] [Open Electrical: AC Power Transmission](#)
- [10] [Decision Tree Based Online Voltage Security Assessment Using PMU Measurements](#), Vijay Vittal, PSERC Seminar, January 27, 200, Arizona State University, slide 26.
- [11] Ibid, 2, Section 5.6.3, page 5-57.
- [12] Ibid, 2, Section 5.6.4, pages 5-57 and 5-58.
- [13] Ibid, 2, Section 5.7.4, page 5-63.
- [14] [Guide to WECC/NERC Planning Standards I.D: Voltage Support and Reactive Power, Reactive Reserve Working Group \(RRWG\)](#), March 30, 2006, Section 3, page 16.
- [15] [Reactive \(VAR\) Reserve Margin](#), NARUC joint meeting Electric Reliability Staff Subcommittee & Electricity Staff Subcommittee, November 13, 2005, slides 14 through 18.
- [16] Ibid, 15.
- [17] Ela, E., Milligan, M., and Kirby, B., Operating Reserves and Variable Generation, NREL, August 2011, Available at: <http://www.nrel.gov/docs/fy11osti/51978.pdf>
- [18] Electric Power Research Institute, “Metrics for Quantifying Flexibility in Power System Planning”, EPRI, Palo Alto, CA. 2014. 3002004243, available at www.epri.com
- [19] P Kundur, *Power System Stability and Control*, McGraw-Hill, 1994, p. 25.

- [20] Lawrence Berkeley National Laboratory, *Use of Frequency Response Metrics to Assess the Planning and Operation Requirements for Reliable Integration of Variable Renewable Generation*, Report LBNL-4142E, December 2010, pp. 13-15.

- [21] National Electric Reliability Council, *Glossary of Terms Used in NERC Reliability Standards*, Updated August 19, 2013

- [22] WECC, “WECC Second Generation Wind Turbine Models,” January 23, 2014.

- [23] National Electric Reliability Council, “*PRC-006-2 - Automatic Under-Frequency Load Shedding*” October 1, 2015.